



Automazioni per cancelli scorrevoli

FA01443M04



BKV15AGE BKV20AGE BKV25AGE
BKV15AGS BKV20AGS BKV25AGS
BKV15ALS BKV20ALS BKV25ALS
BKV15RGS BKV20RGS

MANUALE DI INSTALLAZIONE

IT	Italiano
EN	English
FR	Français
RU	Русский

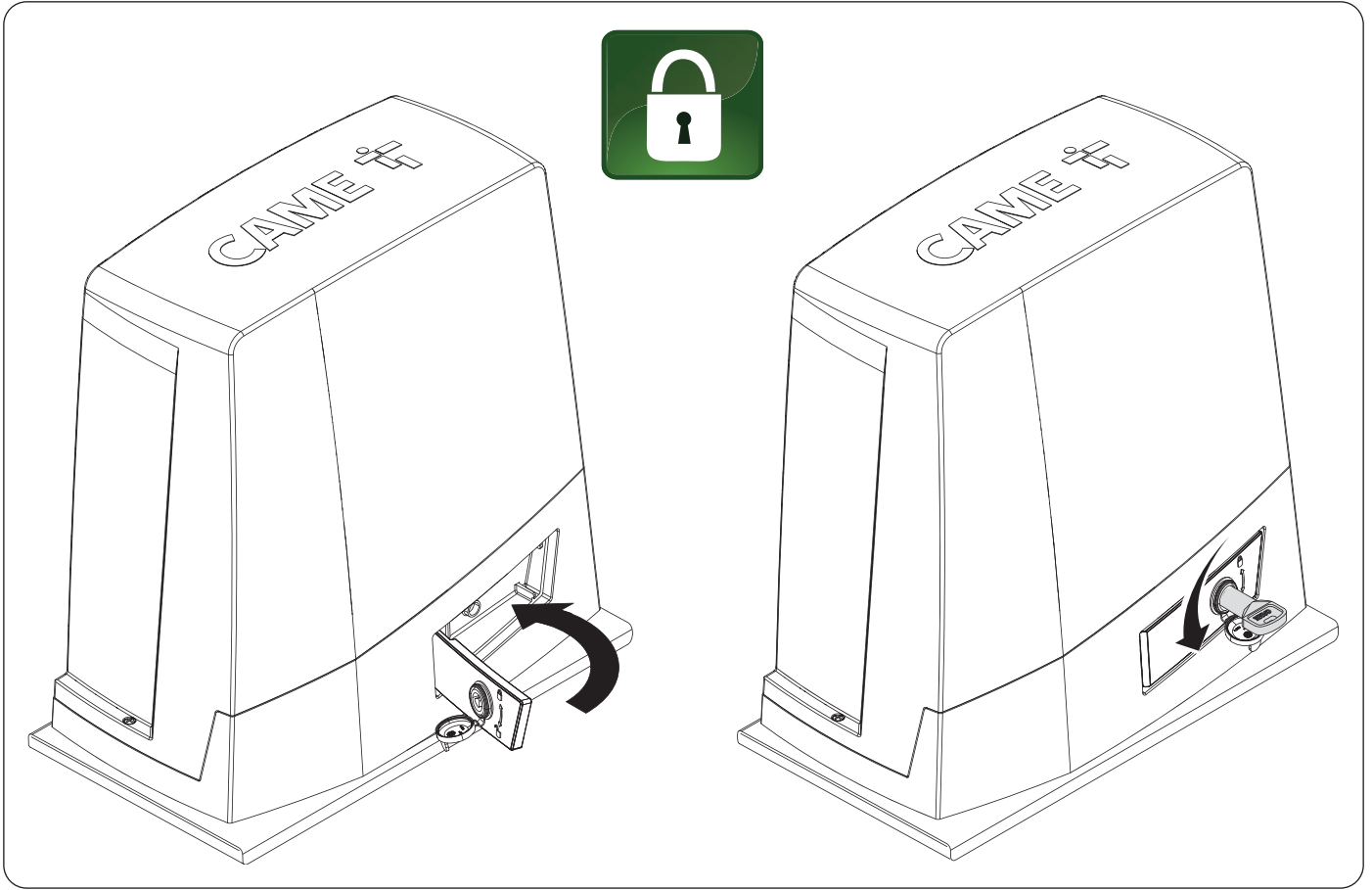
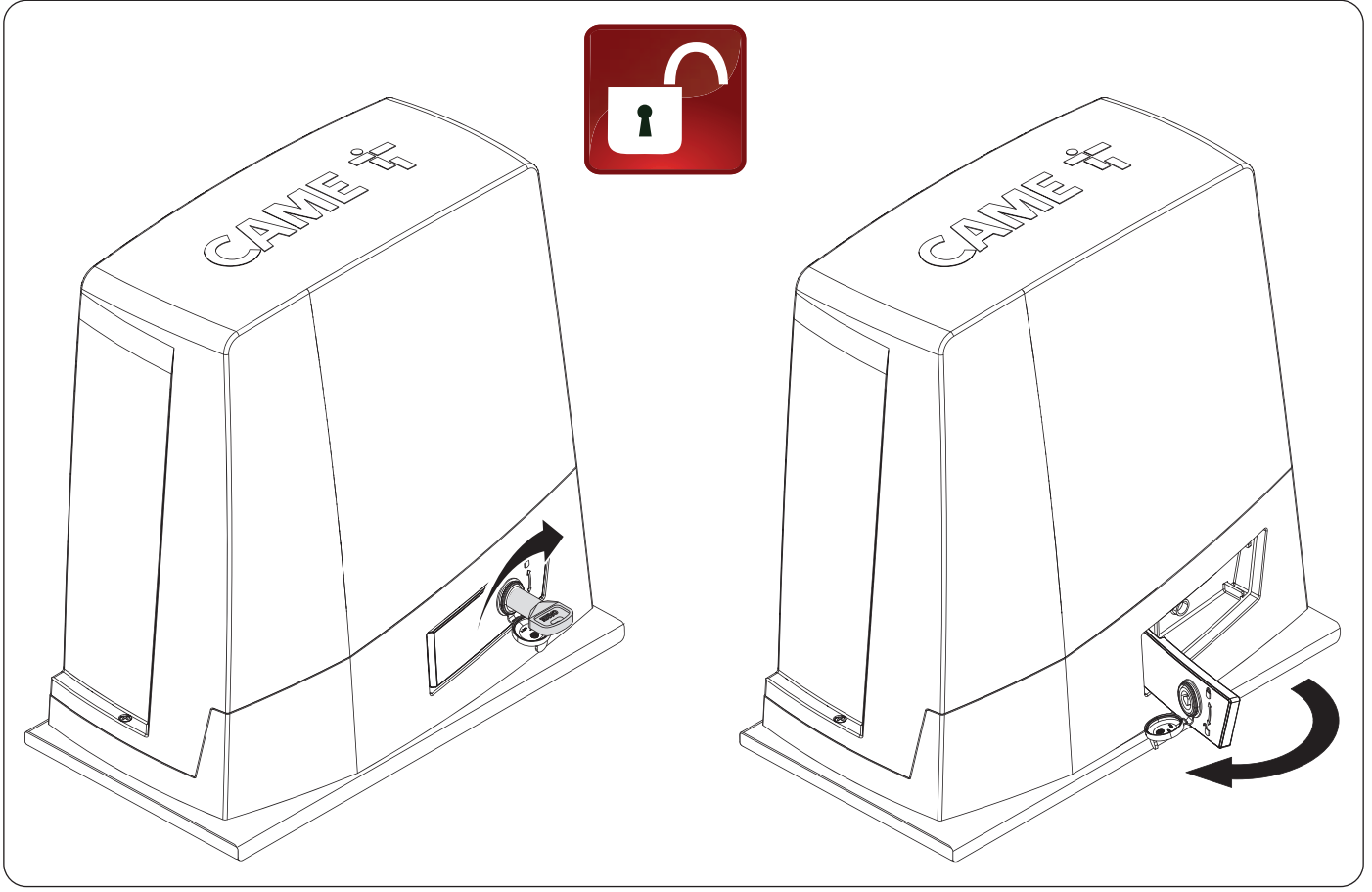

⚠️ *Importanti istruzioni di sicurezza.***⚠️ *Seguire tutte le istruzioni, in quanto un'installazione non corretta può portare a lesioni gravi.*****⚠️ *Prima di procedere, leggere anche le avvertenze generali per l'utilizzatore.***

Il prodotto deve essere destinato solo all'uso per il quale è stato espressamente studiato e ogni altro uso è da considerarsi pericoloso. • Il produttore non può essere considerato responsabile per eventuali danni causati da usi impropri, erronei ed irragionevoli. • Il prodotto oggetto di questo manuale è definito ai sensi della Direttiva Macchine 2006/42/CE come una quasi-macchina. • La quasi-macchina è un insieme che costituisce quasi una macchina, ma che, da solo, non è in grado di garantire un'applicazione ben determinata. • Le quasi-macchine sono unicamente destinate ad essere incorporate o assemblate ad altre macchine o ad altre quasi-macchine o apparecchi per costituire una macchina disciplinata dalla Direttiva Macchine 2006/42/CE. • L'installazione finale deve essere conforme alla Direttiva Macchine 2006/42/CE e agli standard europei di riferimento vigenti. • Il produttore declina ogni responsabilità per l'impiego di prodotti non originali; questo implica anche la decadenza della garanzia. • Tutte le operazioni indicate in questo manuale devono essere effettuate esclusivamente da personale esperto e qualificato e nel pieno rispetto delle normative vigenti. • La predisposizione dei cavi, la posa in opera, il collegamento e il collaudo si devono eseguire osservando la regola dell'arte, in ottemperanza alle norme e leggi vigenti. • Durante tutte le fasi dell'installazione assicurarsi di operare fuori tensione. • Verificare che il range di temperature indicato sia adatto al luogo di installazione. • Non installare in luoghi posti in salita o discesa (ovvero che non siano in piano). • Non montare l'automazione su elementi che potrebbero piegarsi. Se necessario, aggiungere adeguati rinforzi ai punti di fissaggio. • Assicurarsi che, nel luogo previsto per l'installazione, il prodotto non venga bagnato da getti d'acqua diretti (irrigatori, idropultrici, ecc.). • Prevedere nella rete di alimentazione e conformemente alle regole di installazione, un adeguato dispositivo di disconnessione onnipolare, che consenta la disconnessione completa nelle condizioni della categoria di sovratensione III. • Delimitare adeguatamente l'intero sito per evitare l'accesso da parte di persone non autorizzate, in particolare minori e bambini. • Nel caso di movimentazione manuale prevedere una persona per ogni 20 kg da sollevare; nel caso di movimentazione non manuale utilizzare opportuni mezzi per il sollevamento in sicurezza. • Si raccomanda di utilizzare adeguate protezioni per evitare possibili pericoli meccanici dovuti alla presenza di persone nel raggio d'azione dell'automazione. • I cavi elettrici devono passare attraverso apposite tubazioni, canaline e passacavi al fine di garantire un'adeguata protezione contro il danneggiamento meccanico. • I cavi elettrici non devono entrare in contatto con parti che possono riscaldarsi durante l'uso (per esempio: motore e trasformatore). • Prima di procedere con l'installazione, verificare che la parte guidata sia in buone condizioni meccaniche, e che si apra e si chiuda correttamente. • Il prodotto non può essere utilizzato per automatizzare una parte guidata comprensiva di porta pedonale, a meno che l'azionamento non sia attivabile solo con la porta pedonale in posizione di sicurezza. • Assicurarsi che sia evitato l'intrappolamento tra la parte guidata e le parti fisse circostanti a seguito del movimento della parte guidata stessa. • Prevedere un'ulteriore protezione per evitare lo schiacciamento delle dita fra pignone e cremagliera. • Tutti i comandi fissi devono essere chiaramente visibili dopo l'installazione, in una posizione tale che la parte guidata sia visibile in maniera diretta, tuttavia lontani dalle parti in movimento. Nel caso di comando ad azione mantenuta, questo deve essere installato ad un'altezza minima di 1,5 m da terra e non deve essere accessibile al pubblico. • Se non già presente, applicare un'etichetta permanente che descriva come usare il meccanismo di sblocco manuale vicino al relativo elemento di azionamento. • Assicurarsi che l'automazione sia stata regolata adeguatamente e che i dispositivi di sicurezza e protezione, così come lo sblocco manuale, funzionino correttamente. • Prima della consegna all'utente, verificare la conformità dell'impianto alle norme armonizzate ed ai requisiti essenziali nella Direttiva Macchine 2006/42/CE. • Eventuali rischi residui devono essere segnalati mediante opportuni pittogrammi posizionati bene in vista e devono essere spiegati all'utilizzatore finale. • Posizionare bene in vista la targa identificativa della macchina al completamento dell'installazione. • Se il cavo di alimentazione è danneggiato, deve essere sostituito dal produttore o dal servizio di assistenza tecnica autorizzato, o comunque da personale debitamente qualificato, per evitare ogni rischio. • Conservare questo manuale all'interno del fascicolo tecnico congiuntamente ai manuali degli altri dispositivi utilizzati per la realizzazione dell'impianto di automazione. • Si raccomanda di consegnare all'utente finale tutti i manuali d'uso relativi ai prodotti che compongono la macchina finale.

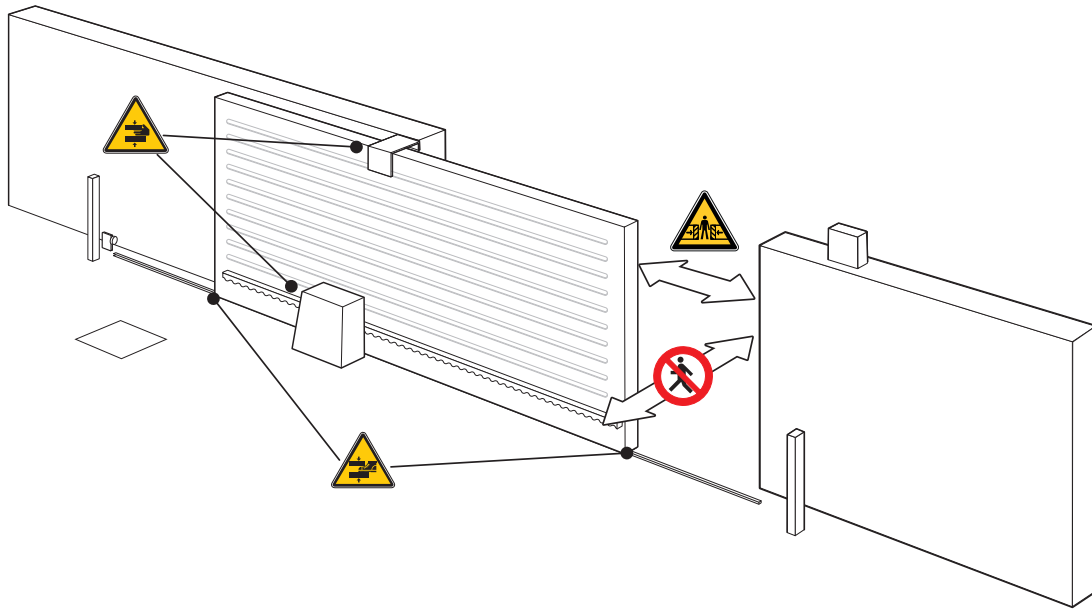

Divieto di transito durante la manovra.



Pericolo di intrappolamento.



Pericolo di intrappolamento mani.



Pericolo di intrappolamento piedi.

DISMISSIONE E SMALTIMENTO

CAME S.p.A. implementa all'interno dei propri stabilimenti un Sistema di Gestione Ambientale certificato e conforme alla norma UNI EN ISO 14001 a garanzia del rispetto e della tutela dell'ambiente. Vi chiediamo di continuare l'opera di tutela dell'ambiente, che CAME considera uno dei fondamenti di sviluppo delle proprie strategie operative e di mercato, semplicemente osservando brevi indicazioni in materia di smaltimento:

SMALTIMENTO DELL'IMBALLO

I componenti dell'imballo (cartone, plastiche, etc.) sono assimilabili ai rifiuti solidi urbani e possono essere smaltiti senza alcuna difficoltà, semplicemente effettuando la raccolta differenziata per il riciclaggio.

Prima di procedere è sempre opportuno verificare le normative specifiche vigenti nel luogo d'installazione.

NON DISPERDERE NELL'AMBIENTE!

SMALTIMENTO DEL PRODOTTO

I nostri prodotti sono realizzati con materiali diversi. La maggior parte di essi (alluminio, plastica, ferro, cavi elettrici) è assimilabile ai rifiuti solidi urbani. Possono essere riciclati attraverso la raccolta e lo smaltimento differenziato nei centri autorizzati.





Altri componenti (schede elettroniche, batterie dei trasmettitori, etc.) possono invece contenere sostanze inquinanti.

Vanno quindi rimossi e consegnati a ditte autorizzate al recupero e allo smaltimento degli stessi.

Prima di procedere è sempre opportuno verificare le normative specifiche vigenti nel luogo di smaltimento.

NON DISPERDERE NELL'AMBIENTE!

Legenda

-  Questo simbolo indica parti da leggere con attenzione.
-  Questo simbolo indica parti riguardanti la sicurezza.
-  Questo simbolo indica cosa comunicare all'utente.
-  Le misure, se non diversamente indicato, sono in millimetri.

Descrizione

801MS-0300

BKV15AGS - Automazione con motore a 36 V, completa di scheda elettronica con display grafico, Adaptive Speed & Torque Technology, 4 ingressi di sicurezza, gestione del movimento e rilevazione degli ostacoli per cancelli fino a 1500 kg e 20 m di lunghezza.

801MS-0310

BKV20AGS - Automazione con motore a 36 V, completa di scheda elettronica con display grafico, Adaptive Speed & Torque Technology, 4 ingressi di sicurezza, gestione del movimento e rilevazione degli ostacoli per cancelli fino a 2000 kg e 20 m di lunghezza.

801MS-0320

BKV25AGS - Automazione con motore a 36 V, completa di scheda elettronica con display grafico, Adaptive Speed & Torque Technology, 4 ingressi di sicurezza, gestione del movimento/rilevazione degli ostacoli e pignone modulo 6 per cancelli fino a 2500 kg e 20 m di lunghezza.

801MS-0330

BKV15RGS - Automazione ad alte performance con motore a 36 V, completa di scheda elettronica con display grafico, Adaptive Speed & Torque Technology, 4 ingressi di sicurezza, gestione del movimento e rilevazione degli ostacoli per cancelli fino a 1500 kg e 20 m di lunghezza.

801MS-0340

BKV20RGS - Automazione ad alte performance con motore a 36 V, completa di scheda elettronica con display grafico, Adaptive Speed & Torque Technology, 4 ingressi di sicurezza, gestione del movimento e rilevazione degli ostacoli per cancelli fino a 2000 kg e 20 m di lunghezza.

801MS-0350

BKV15AGE - Automazione versione Plus con motore a 36 V, completa di scheda elettronica con display grafico, Adaptive Speed & Torque Technology, 4 ingressi di sicurezza, fincorsa magnetici e accessorio clock incluso per cancelli fino a 1500 kg e 20 m di lunghezza.

801MS-0360

BKV20AGE - Automazione versione Plus con motore a 36 V, completa di scheda elettronica con display grafico, Adaptive Speed & Torque Technology, 4 ingressi di sicurezza, fincorsa magnetici e accessorio clock incluso per cancelli fino a 2000 kg e 20 m di lunghezza.

801MS-0370

BKV25AGE - Automazione versione Plus con motore a 36 V, completa di scheda elettronica con display grafico, Adaptive Speed & Torque Technology, 4 ingressi di sicurezza, pignone modulo 6, fincorsa magnetici e accessorio clock incluso per cancelli fino a 2500 kg e 20 m di lunghezza.

801MS-0301

BKV15ALS - Automazione ad alte performance con motore a 36 V, completa di scheda elettronica con display grafico, Adaptive Speed & Torque Technology, 4 ingressi di sicurezza, gestione del movimento e rilevazione degli ostacoli per cancelli fino a 1500 kg e 20 m di lunghezza. Cover grigio RAL 7040.

801MS-0311

BKV20ALS - Automazione ad alte performance con motore a 36 V, completa di scheda elettronica con display grafico, Adaptive Speed & Torque Technology, 4 ingressi di sicurezza, gestione del movimento e rilevazione degli ostacoli per cancelli fino a 2000 kg e 20 m di lunghezza. Cover grigio RAL 7040.

801MS-0321

BKV25ALS - Automazione ad alte performance con motore a 36 V, completa di scheda elettronica con display grafico, Adaptive Speed & Torque Technology, 4 ingressi di sicurezza, gestione del movimento/rilevazione degli ostacoli e pignone modulo 6 per cancelli fino a 2500 kg e 20 m di lunghezza. Cover grigio RAL 7040.

Destinazione d'uso

Soluzione per cancelli scorrevoli di grandi dimensioni

 Ogni installazione e uso difforni da quanto indicato nel seguente manuale sono da considerarsi vietate.

Descrizione delle parti

Automazione

- ❶ Coperchio
- ❷ Coperchio di protezione scheda
- ❸ Scheda elettronica
- ❹ Supporto porta-schede
- ❺ Motoriduttore
- ❻ Finecorsa meccanico
- ❼ Piastra di fissaggio
- ❽ Alloggiamento per n. 2 batterie di emergenza
- ❾ Alloggiamento per termostato con cartuccia
- ❿ Alloggiamento per modulo RGSM001
- ⓫ Alloggiamento per scheda LBB
- ⓬ Alloggiamento per modulo RGP1
- ⓭ Leva di sblocco
- ⓮ Alette per finecorsa meccanico
- ⓯ Minuteria di fissaggio
- ⓰ Alloggiamento per modulo UR042
- ⓱ Fori per il passaggio dei cavi elettrici
- ⓲ Alloggiamento per modulo SMA
- ⓳ Finecorsa magnetico*
- ⓴ Alette per finecorsa magnetico*
- ⓵ Scheda clock (806SA-0120)*

* Solo per BKV15AGE, BKV20AGE e BKV25AGE

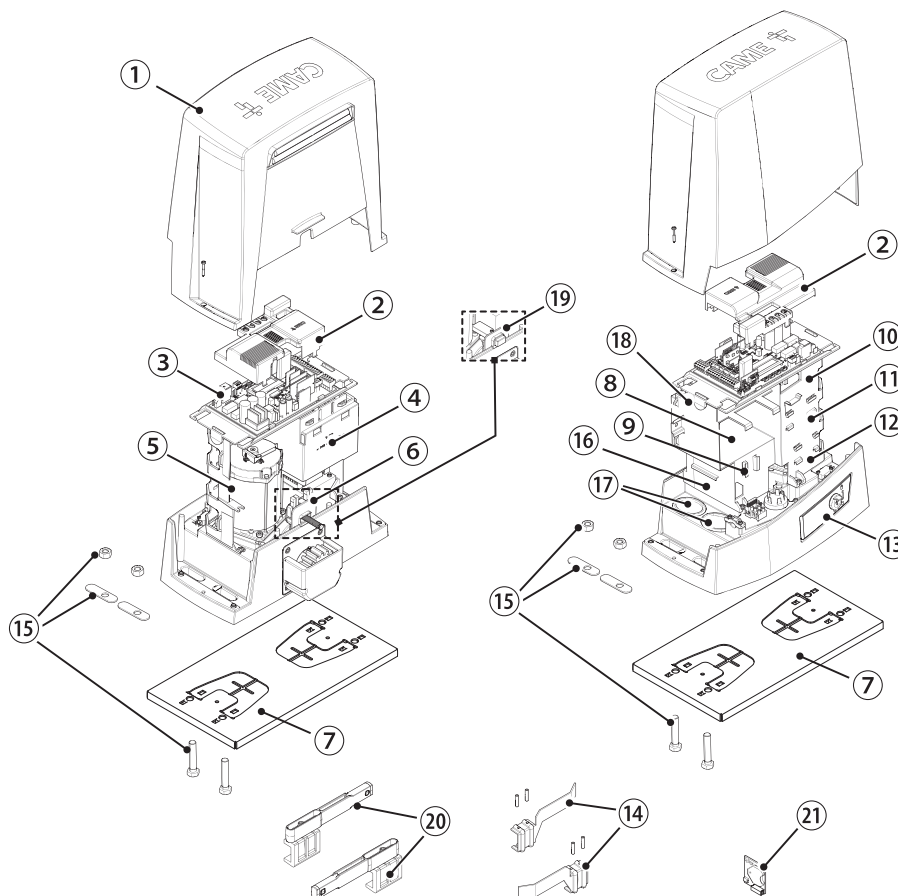

Scheda elettronica

Le funzioni sui contatti di ingresso e di uscita le regolazioni dei tempi e la gestione degli utenti sono impostate e visualizzate sul display.

Tutte le connessioni sono protette da fusibili rapidi.

Per un funzionamento corretto, prima di inserire una qualsiasi scheda a innesto, è **OBBLIGATORIO TOGLIERE LA TENSIONE DI LINEA** e, se presenti, scollegare le batterie.

Prima di intervenire sul quadro di comando, togliere la tensione di linea e, se presenti, scollegare le batterie.

- | | |
|---|---|
| <ul style="list-style-type: none"> ❶ Morsettiera per il collegamento del motoriduttore ❷ Morsettiera per il collegamento dell'Encoder ❸ Morsettiera per il collegamento del modulo RGP1 o scheda LBB ❹ Tasti per la programmazione ❺ Connettore per scheda RSE ❻ Connettore per CAME KEY ❼ Connettore per scheda radiofrequenza a innesto (AF) ❽ Morsettiera per il collegamento dell'antenna ❾ Morsettiera per il collegamento dei dispositivi di sicurezza ❿ Morsettiera per il collegamento della funzione abbinata o CRP ⓫ Morsettiera per il collegamento dei dispositivi di comando ⓬ Morsettiera per il collegamento del selettore a tastiera ⓭ Morsettiera per il collegamento del selettore transponder | <ul style="list-style-type: none"> ⓮ Morsettiera per il collegamento dei dispositivi di segnalazione ⓯ Morsettiera per l'uscita B1-B2 ⓰ Connettore per scheda di decodifica R700 o R800 ⓱ Connettore per modulo RIOCN8WS ⓲ Connettore per scheda clock (806SA-0120) ⓳ Morsettiera per microinterruttori di finecorsa ⓴ Fusibile per gli accessori ⓵ Fusibile per la scheda elettronica ⓶ Morsettiera per il collegamento del trasformatore ⓷ Connettore per scheda Memory Roll ⓸ Display ⓹ Fusibile di linea ⓺ Morsettiera per l'alimentazione |
|---|---|

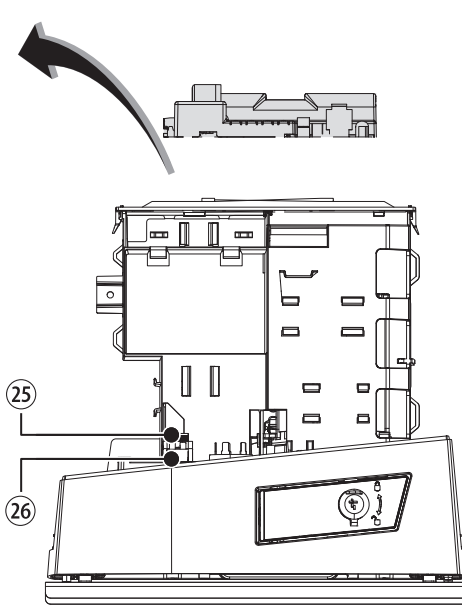
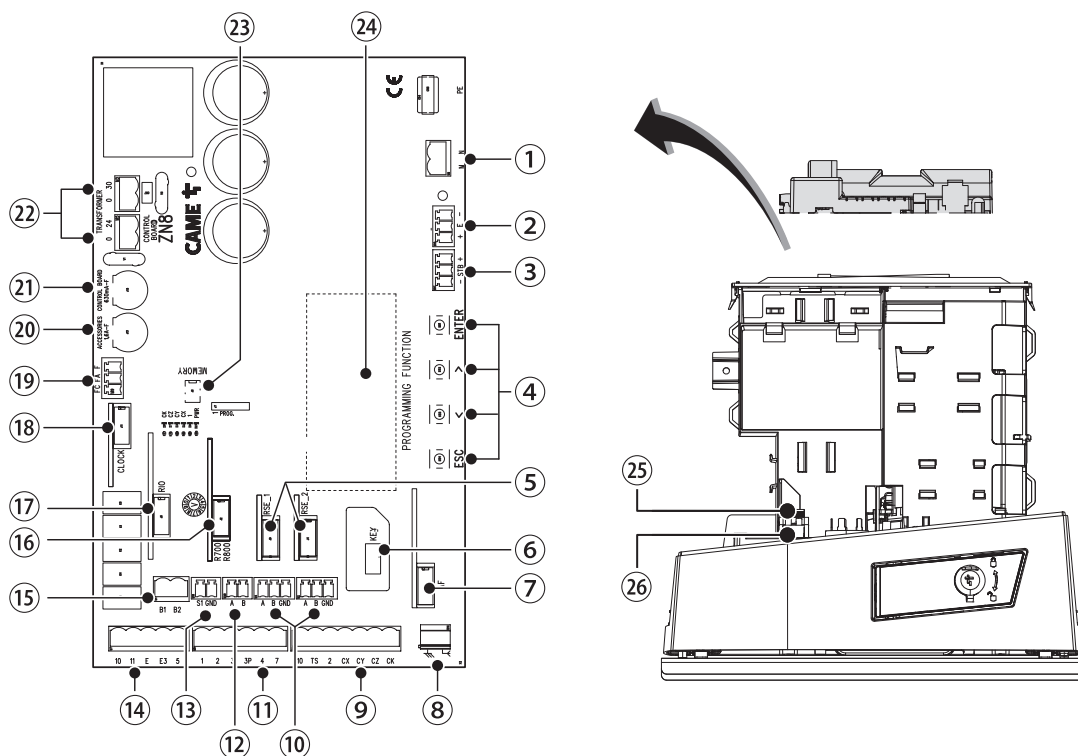

Per poter inserire le schede a innesto nei connettori dedicati, rimuovere il coperchio della scheda.

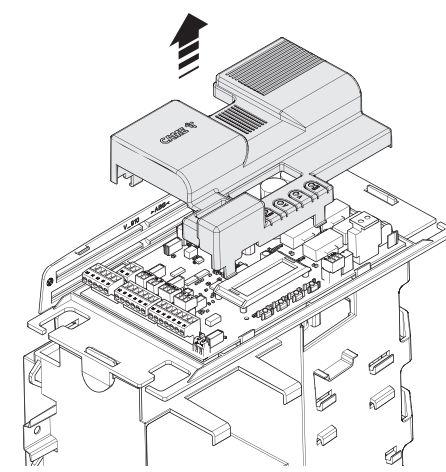
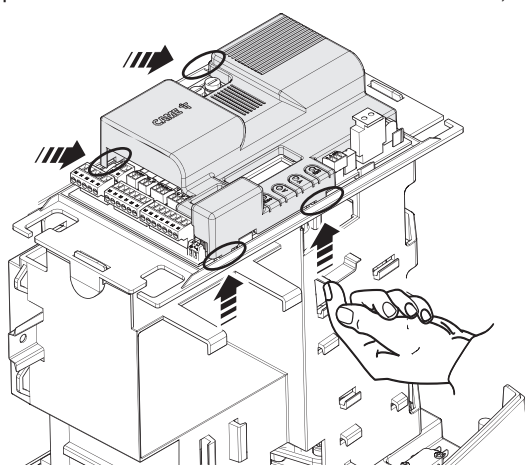

Dimensioni

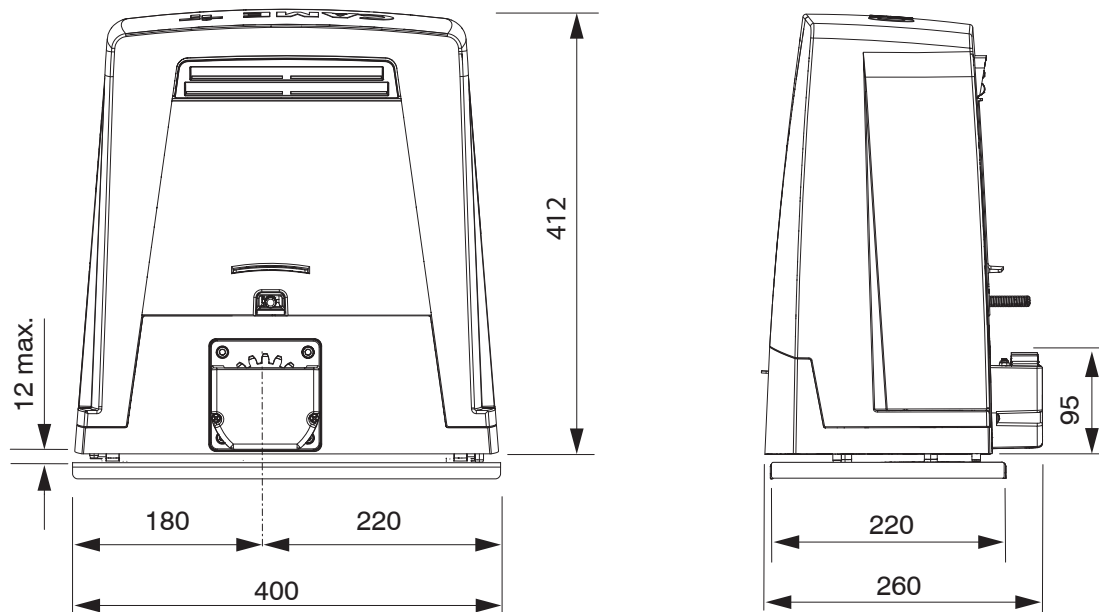

Limiti di impiego

MODELLI	BKV15AGS	BKV20AGS	BKV25AGS	BKV15RGS	BKV20RGS
Modulo del pignone	4	4	6	4	4
Lunghezza massima anta (m)	20	20	20	20	20
Peso massimo anta (kg)	1500	2000	2500	1500	2000

MODELLI	BKV15AGE	BKV20AGE	BKV25AGE	BKV15ALS	BKV20ALS	BKV25ALS
Modulo del pignone	4	4	6	4	4	6
Lunghezza massima anta (m)	20	20	20	20	20	20
Peso massimo anta (kg)	1500	2000	2500	1500	2000	2500

Dati tecnici

MODELLI	BKV15AGS	BKV20AGS	BKV25AGS	BKV15RGS	BKV20RGS
Alimentazione (V - 50/60 Hz)	230 AC	230 AC	230 AC	120 AC	120 AC
Alimentazione motore (V)	36 DC	36 DC	36 DC	36 DC	36 DC
Alimentazione scheda (V)	26 DC	26 DC	26 DC	26 DC	26 DC
Consumo in stand-by (W)	14	14	14	14	14
Consumo in stand-by con il modulo RGP1 (W)	0,8	0,8	0,8	0,8	0,8
Potenza (W)	200	250	300	200	250
Termo-protezione trasformatore (°C)	120	120	120	120	120
Corrente assorbita (A)	8	9	10	8	9
Massima corrente assorbita (A)	20	20	20	20	20
Colore	RAL 7024	RAL 7024	RAL 7024	RAL 7024	RAL 7024
Temperatura d'esercizio (°C)	-20 ÷ +55	-20 ÷ +55	-20 ÷ +55	-20 ÷ +55	-20 ÷ +55
Spinta (N)	800	900	1000	800	900
Massima spinta (N)	1200	1350	1500	1200	1350
Velocità massima di manovra (m/min)	12	12	12	12	12
Tempo lavoro (s)	180	180	180	180	180
Cicli/ora	SERVIZIO CONTINUO	SERVIZIO CONTINUO	SERVIZIO CONTINUO	SERVIZIO CONTINUO	SERVIZIO CONTINUO
Grado di protezione (IP)	54	54	54	54	54
Classe di isolamento	I	I	I	I	I
Rapporto di riduzione (i)	40	40	40	40	40
Peso (kg)	20	21	21	20	21

MODELLI	BKV15AGE	BKV20AGE	BKV25AGE	BKV15ALS	BKV20ALS	BKV25ALS
Alimentazione (V - 50/60 Hz)	230 AC	230 AC	230 AC	230 AC	230 AC	230 AC
Alimentazione motore (V)	36 DC	36 DC	36 DC	36 DC	36 DC	36 DC
Alimentazione scheda (V)	26 DC	26 DC	26 DC	26 DC	26 DC	26 DC
Consumo in stand-by (W)	14	14	14	14	14	14
Consumo in stand-by con il modulo RGP1 (W)	0,8	0,8	0,8	0,8	0,8	0,8
Potenza (W)	200	250	300	200	250	300
Termo-protezione trasformatore (°C)	120	120	120	120	120	120
Corrente assorbita (A)	8	9	10	8	9	10
Massima corrente assorbita (A)	20	20	20	20	20	20
Colore	RAL 7024	RAL 7024	RAL 7024	RAL 7040	RAL 7040	RAL 7040
Temperatura d'esercizio (°C)	-20 ÷ +55	-20 ÷ +55	-20 ÷ +55	-20 ÷ +55	-20 ÷ +55	-20 ÷ +55
Spinta (N)	800	900	1000	800	900	1000
Massima spinta (N)	1200	1350	1500	1200	1350	1500
Velocità massima di manovra (m/min)	12	12	12	12	12	12
Tempo lavoro (s)	180	180	180	180	180	180
Cicli/ora	SERVIZIO CONTINUO	SERVIZIO CONTINUO	SERVIZIO CONTINUO	SERVIZIO CONTINUO	SERVIZIO CONTINUO	SERVIZIO CONTINUO
Grado di protezione (IP)	54	54	54	54	54	54
Classe di isolamento	I	I	I	I	I	I
Rapporto di riduzione (i)	40	40	40	40	40	40
Peso (kg)	20	21	21	20	21	21

Tabella dei fusibili

MODELLI	BKV15AGS	BKV20AGS	BKV25AGS	BKV15RGS	BKV20RGS
Fusibile di linea	2 A F	2 A F	2 A F	4 A F	4 A F
Fusibile scheda	630 mA F	630 mA F	630 mA F	630 mA F	630 mA F
Fusibile accessori	1,6 A F	1,6 A F	1,6 A F	1,6 A F	1,6 A F

MODELLI	BKV15AGE	BKV20AGE	BKV25AGE	BKV15ALS	BKV20ALS	BKV25ALS
Fusibile di linea	2 A F	2 A F	2 A F	2 A F	2 A F	2 A F
Fusibile scheda	630 mA F	630 mA F	630 mA F	630 mA F	630 mA F	630 mA F
Fusibile accessori	1,6 A F	1,6 A F	1,6 A F	1,6 A F	1,6 A F	1,6 A F

Tipi di cavi e spessori minimi

Lunghezza del cavo (m)	fino a 20	da 20 a 30
Alimentazione 230 V AC	3G x 1,5 mm ²	3G x 2,5 mm ²
Lampeggiatore 24 V AC/DC	2 x 1 mm ²	2 x 1 mm ²
Fotocellule TX	2 x 0,5 mm ²	2 x 0,5 mm ²
Fotocellule RX	4 x 0,5 mm ²	4 x 0,5 mm ²
Dispositivi di comando	*n° x 0,5 mm ²	*n° x 0,5 mm ²

*n° = vedi istruzioni di montaggio del prodotto - Attenzione: la sezione del cavo è indicativa perché varia in funzione della potenza del motore e della lunghezza del cavo.

 Con alimentazione a 230 V e utilizzo in ambiente esterno, utilizzare cavi tipo H05RN-F conformi alla 60245 IEC 57 (IEC); in ambiente interno invece, utilizzare cavi tipo H05VV-F conformi alla 60227 IEC 53 (IEC). Per alimentazioni fino a 48 V, si possono utilizzare cavi tipo FROR 20-22 II conformi alla EN 50267-2-1 (CEI).

 Per il collegamento dell'antenna, utilizzare cavo tipo RG58 (consigliato fino a 5 m).

 Per il collegamento abbinato e CRP, utilizzare cavo tipo UTP CAT5 (fino a 1000 m).

 Qualora i cavi abbiano lunghezza diversa rispetto a quanto previsto in tabella, si determini la sezione dei cavi sulla base dell'effettivo assorbimento dei dispositivi collegati e secondo le prescrizioni indicate dalla normativa CEI EN 60204-1.

 Per i collegamenti che prevedano più carichi sulla stessa linea (sequenziali), il dimensionamento a tabella deve essere riconsiderato sulla base degli assorbimenti e delle distanze effettive. Per i collegamenti di prodotti non contemplati in questo manuale fa fede la documentazione allegata ai prodotti stessi.

INSTALLAZIONE

Le seguenti illustrazioni sono solo esempi in quanto lo spazio per il fissaggio dell'automazione e degli accessori varia a seconda della zona di installazione. Spetta all'installatore scegliere la soluzione più adatta.

I disegni si riferiscono all'automazione installata a sinistra.

Operazioni preliminari

Fare lo scavo per la cassa matta.

Preparare i tubi corrugati necessari per i collegamenti provenienti dal pozzetto di derivazione.

Per il collegamento del motoriduttore e degli accessori, si consigliano tubi corrugati \varnothing 40 mm.

Il numero di tubi dipende dal tipo di impianto e dagli accessori previsti.

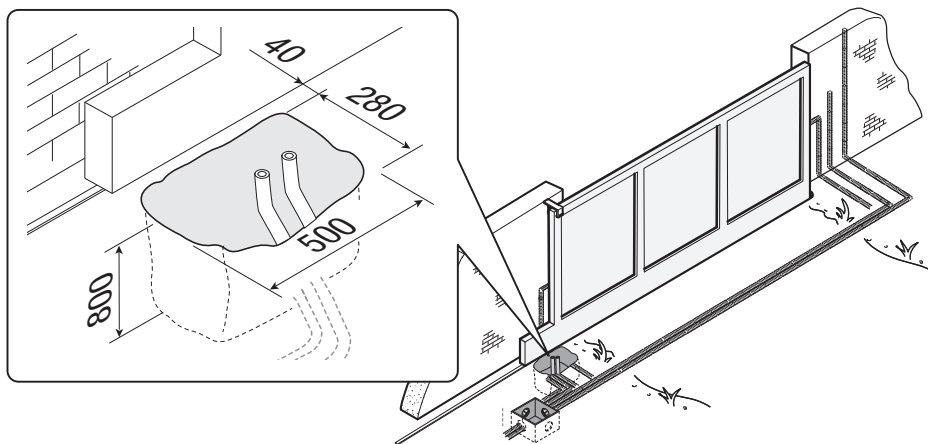

Posa della piastra di fissaggio

Preparare una cassa matta di dimensioni maggiori alla piastra di fissaggio.

Inserire la cassa matta nello scavo.

La cassa matta deve sporgere di 50 mm dal livello del suolo.

Inserire una griglia di ferro nella cassa matta per armare il cemento.

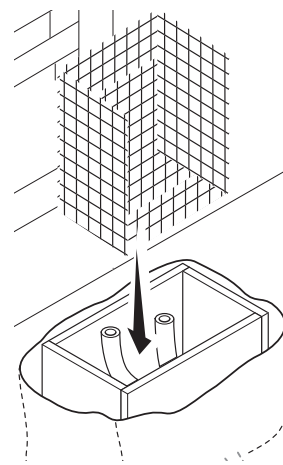
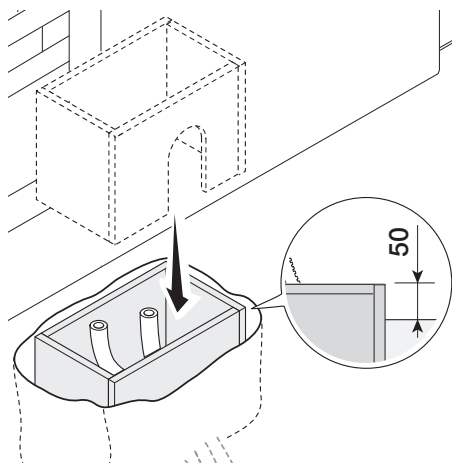

Inserire le viti fornite nella piastra di fissaggio.
 Bloccare le viti con i dadi forniti.
 Estrarre le zanche preformate, utilizzando un cacciavite.
 Inserire la piastra di fissaggio nella griglia di ferro.

 I tubi devono passare attraverso i fori predisposti.

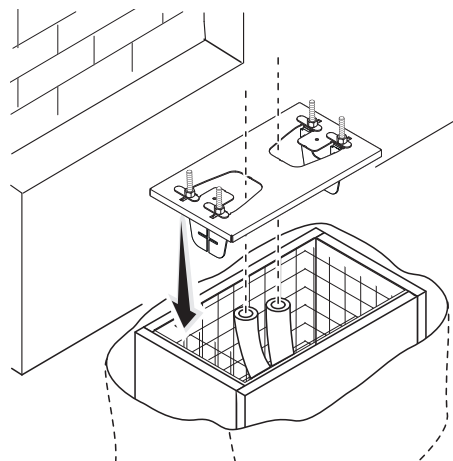
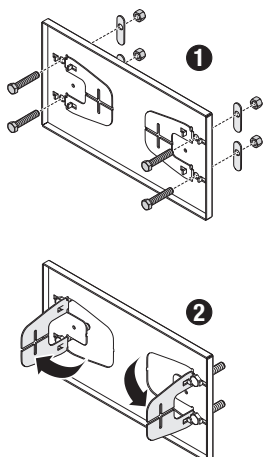

Posizionare la piastra di fissaggio rispettando le misure riportate sul disegno.

 Se il cancello non ha la cremagliera, procedere con l'installazione.

 Vedere il paragrafo FISSAGGIO DELLA CREMAGLIERA.

Riempire la cassa matta di cemento.

 La piastra deve essere perfettamente in bolla e con il filetto delle viti completamente in superficie.

Attendere che il cemento solidifichi per almeno 24 ore.

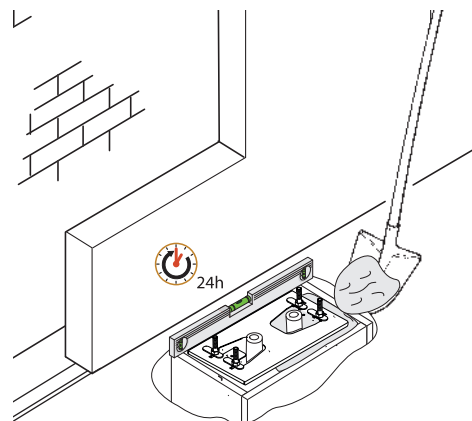
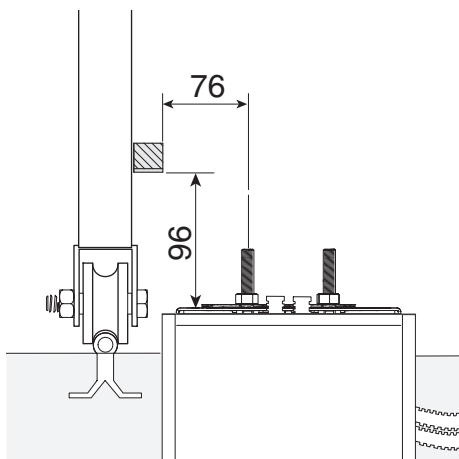

Togliere la cassa matta.

Riempire di terra lo scavo attorno al blocco di cemento.

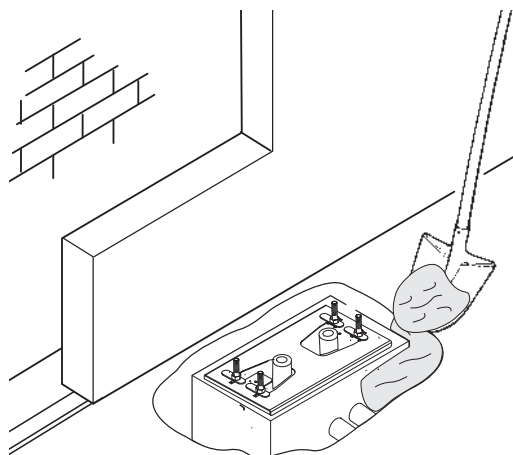
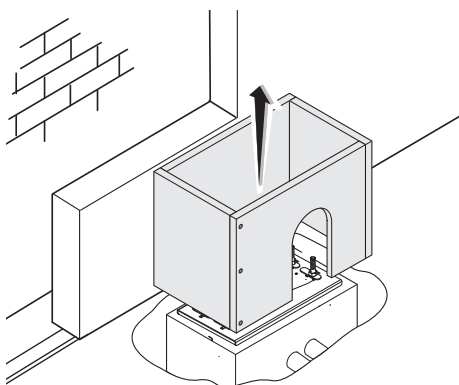

Togliere i dadi dalle viti.
Inserire i cavi elettrici nei tubi fino a farli uscire di 600 mm circa.

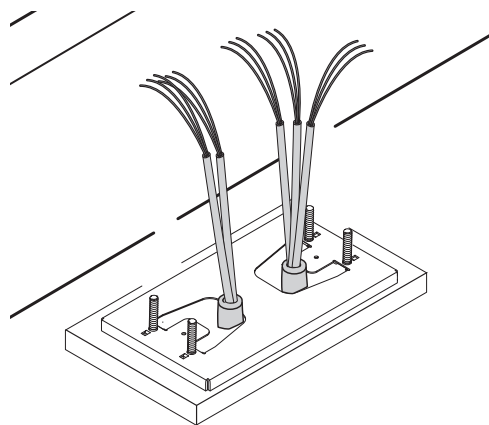
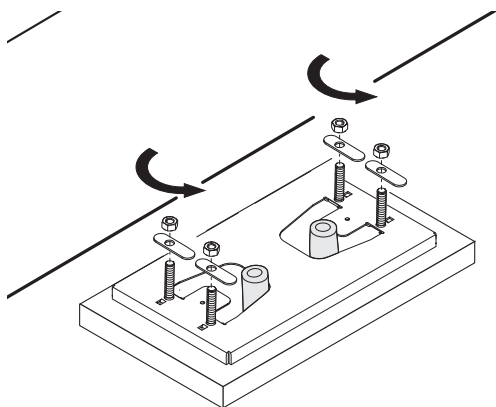

Preparazione dell'automazione

Rimuovere il coperchio dell'automazione.
Posizionare l'automazione sopra la piastra di fissaggio.

 I cavi elettrici devono passare sotto la cassa dell'automazione

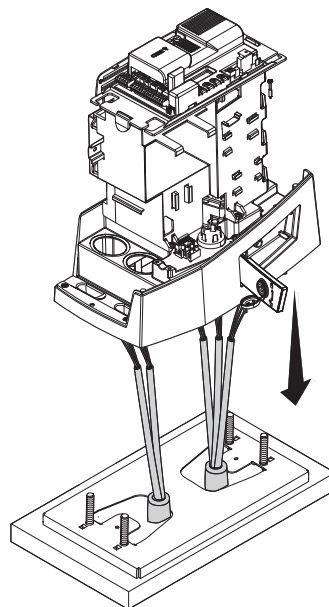
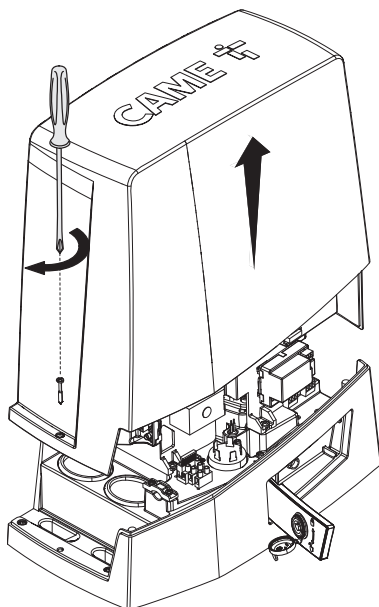

Forare il passacavo.

Infilare il passacavo nei cavi.

Sollevare l'automazione di 5÷10 mm dalla piastra agendo sui piedini filettati per permettere eventuali regolazioni successive tra pignone e cremagliera.

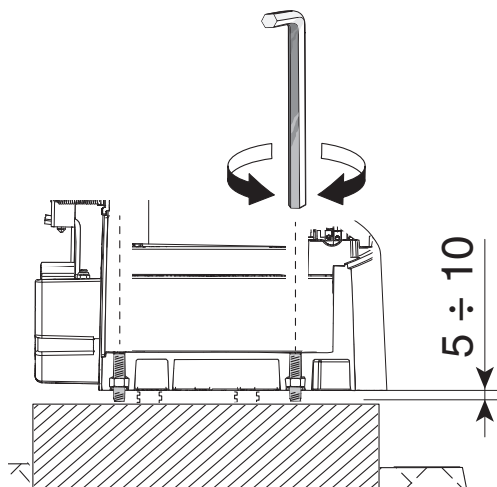
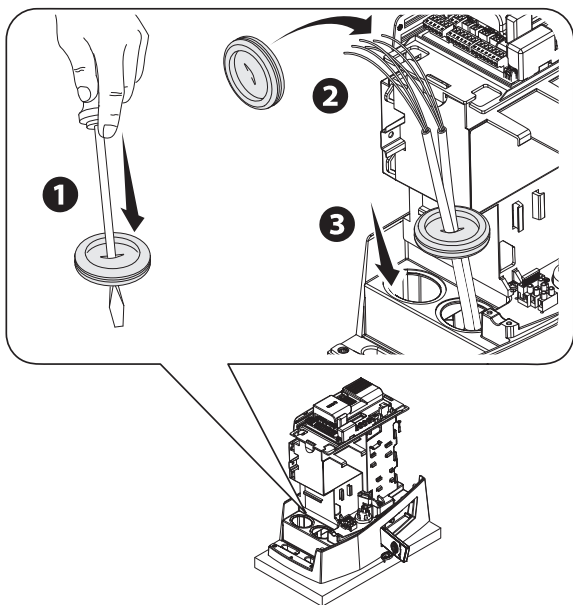

Fissaggio della cremagliera

1 Sbloccare l'automazione.

2 Appoggiare la cremagliera sul pignone.

3 Saldare o fissare la cremagliera al cancello in tutta la sua lunghezza.

 Per assemblare i moduli della cremagliera, utilizzare un pezzo di scarto appoggiandolo sotto il punto di giuntura e bloccandolo con due morsetti.

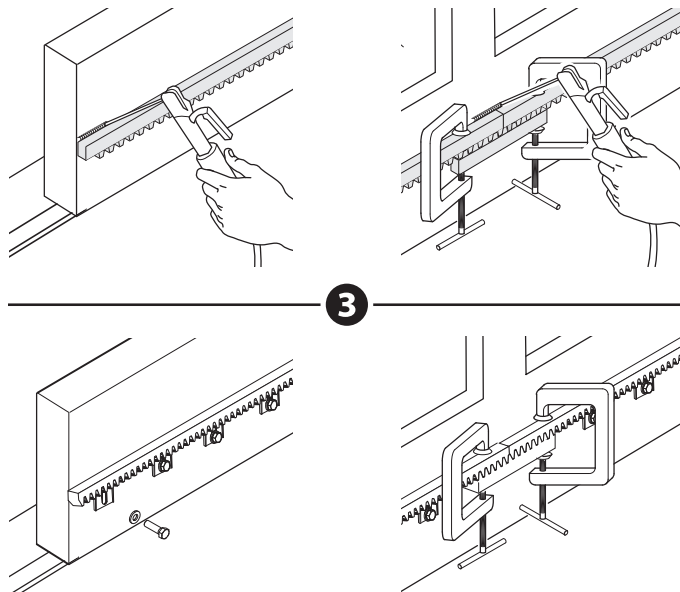
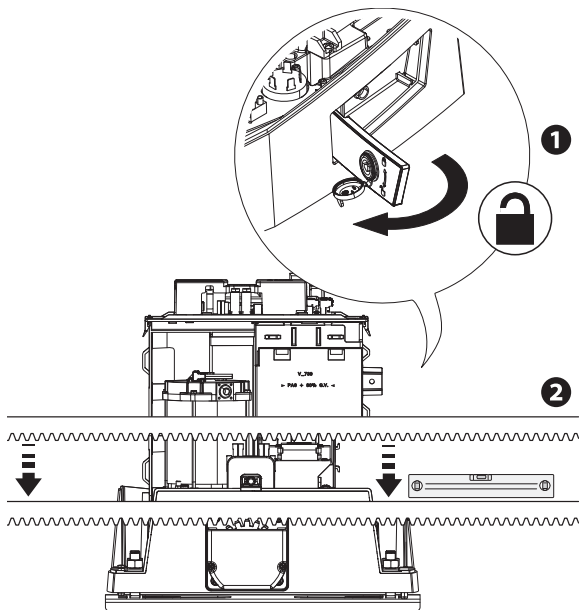

Regolazione accoppiamento pignone-cremagliera

Aprire e chiudere il cancello manualmente.

Registrare la distanza dell'accoppiamento pignone-cremagliera con i piedini filettati (regolazione verticale) e le asole (regolazione orizzontale).

 Il peso del cancello non deve gravare sull'automazione.

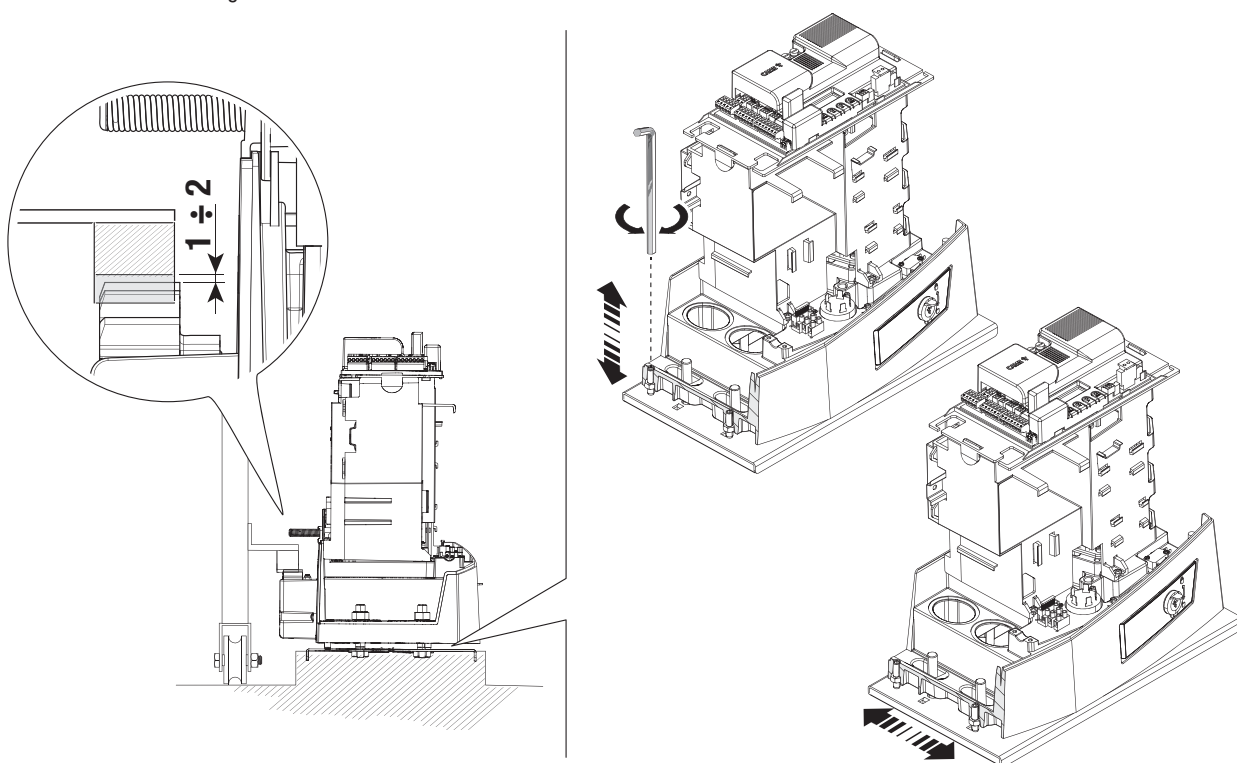

Fissaggio dell'automazione

 Procedere al fissaggio solo dopo aver regolato l'accoppiamento pignone-cremagliera.

Fissare l'automazione alla piastra di fissaggio con gli scontri e i dadi.

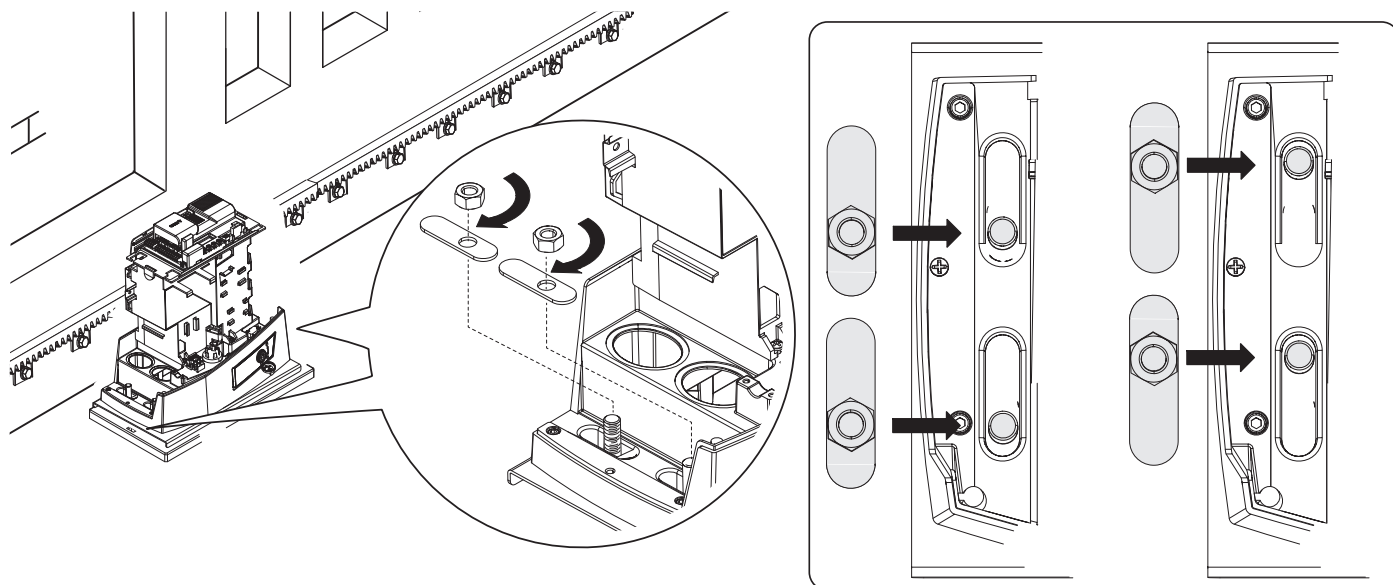

Determinazione dei punti di finecorsa con finecorsa meccanici

- 1 Aprire il cancello.
- 2 Infilare l'aletta di finecorsa di apertura sulla cremagliera.
La molla deve far scattare il micro.
- 3 Fissare l'aletta di finecorsa di apertura con le viti senza testa (fornite).

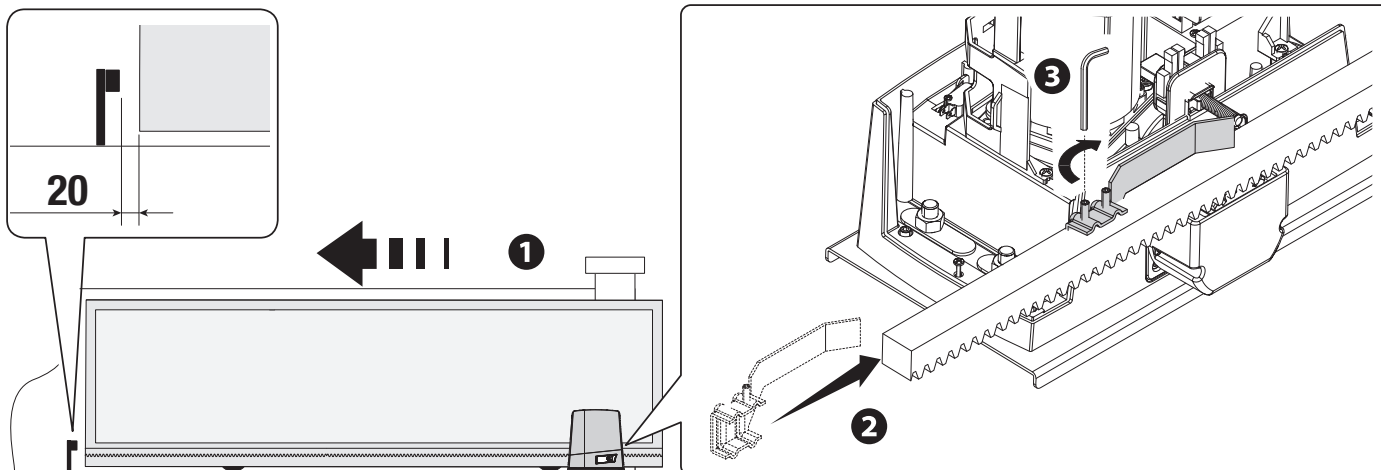

- 4 Chiudere il cancello.
- 5 Infilare l'aletta di finecorsa di chiusura sulla cremagliera.
La molla deve far scattare il micro.
- 6 Fissare l'aletta di finecorsa di chiusura con le viti senza testa (fornite).

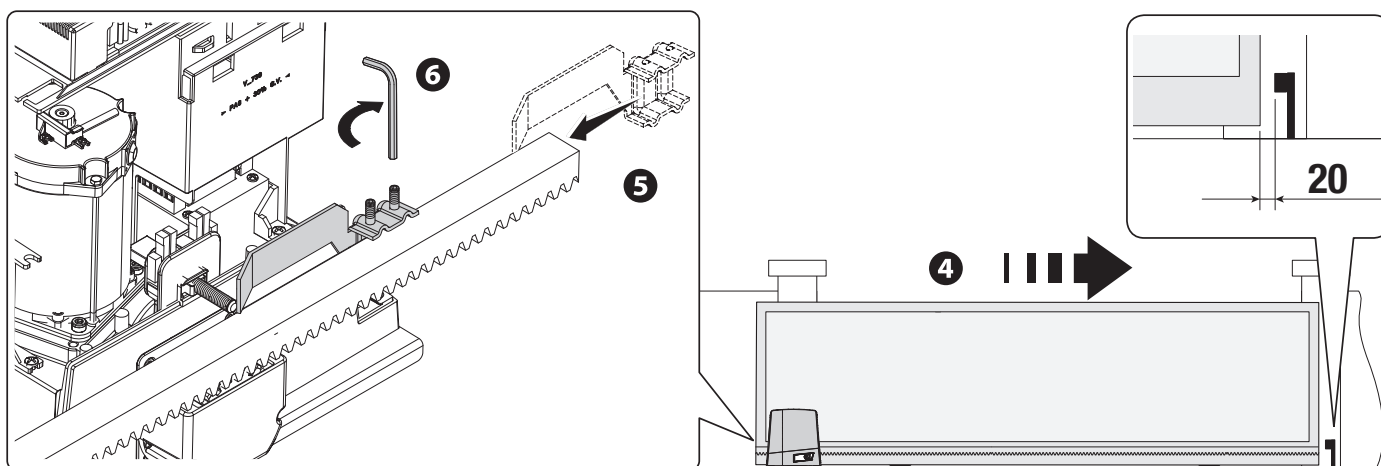

Determinazione dei punti di finecorsa con finecorsa magnetici

* Solo per BKV15AGE, BKV20AGE e BKV25AGE

- A** Aletta per finecorsa magnetico in chiusura
- B** Aletta per finecorsa magnetico in apertura

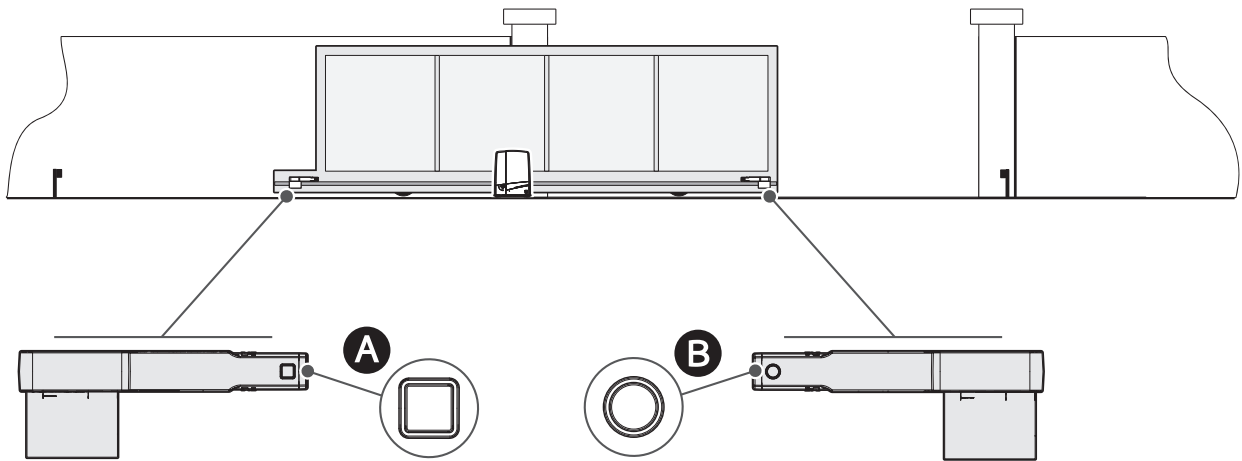

Aprire il cancello.

Infilare l'aletta magnetica di finecorsa di apertura sulla cremagliera.

Il magnete dell'aletta deve stare a una distanza compresa tra 10 e 30 mm dal sensore magnetico.

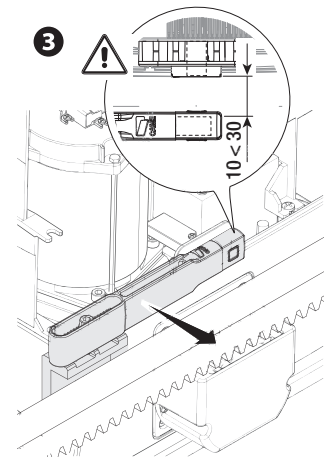
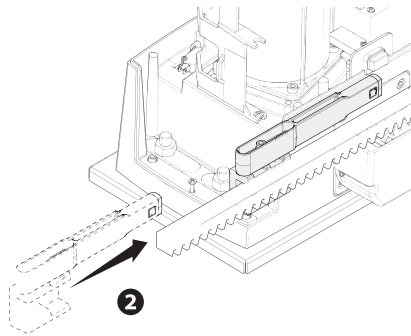
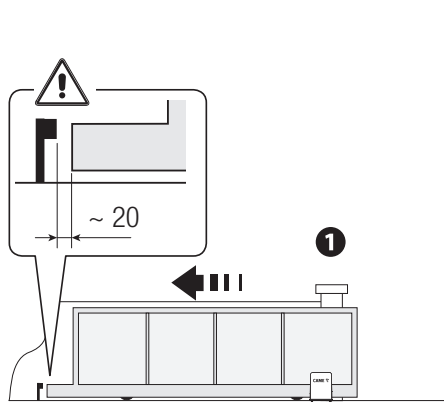

Fissare il supporto alla cremagliera, utilizzando le viti senza testa (fornite).

Il magnete dell'aletta di finecorsa deve essere perpendicolare al sensore magnetico.

Fissare l'aletta di finecorsa con la vite (fornita).

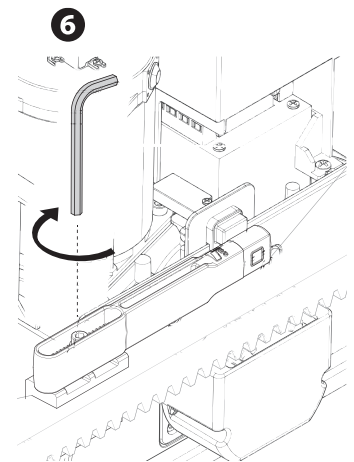
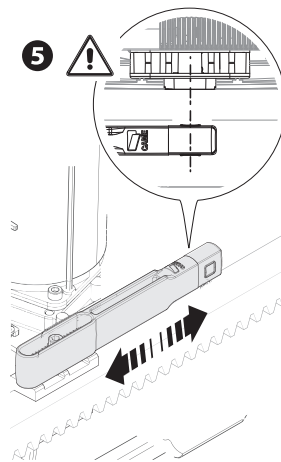
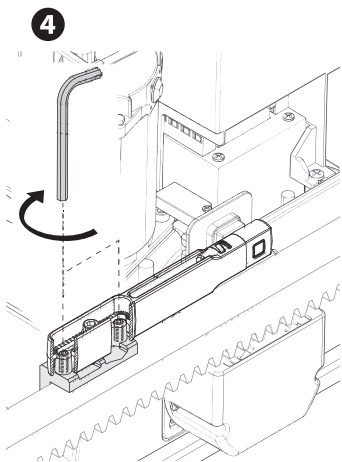

Chiudere il cancello.

Infilare l'aletta magnetica di finecorsa di chiusura sulla cremagliera.

 Il magnete dell'aletta deve stare a una distanza compresa tra 10 e 30 mm dal sensore magnetico.

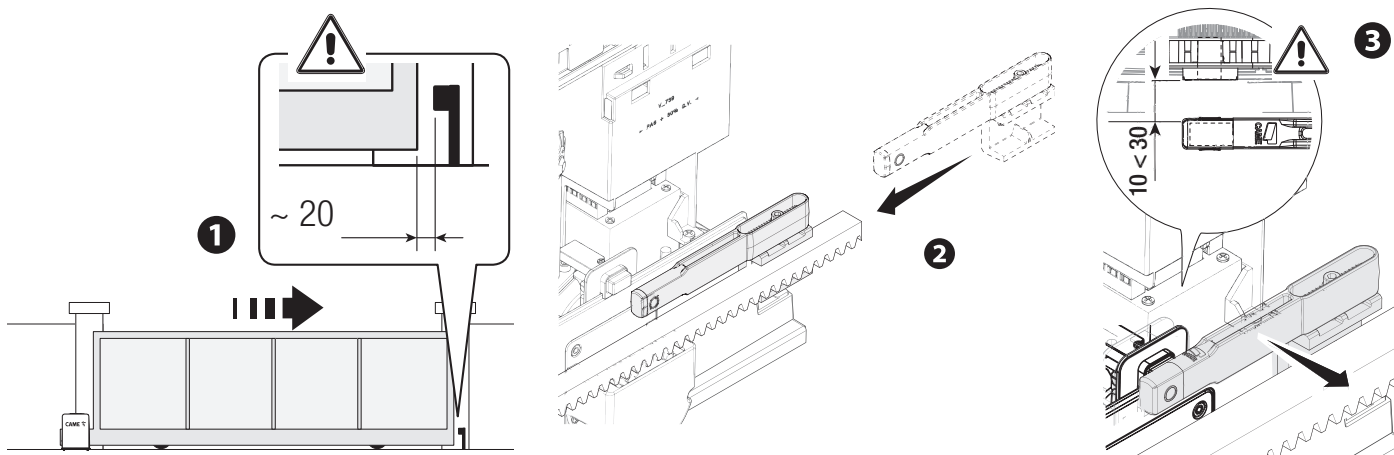

Fissare il supporto alla cremagliera, utilizzando le viti senza testa (fornite).

 Il magnete dell'aletta di finecorsa deve essere perpendicolare al sensore magnetico.

Fissare l'aletta di finecorsa con la vite (fornita).

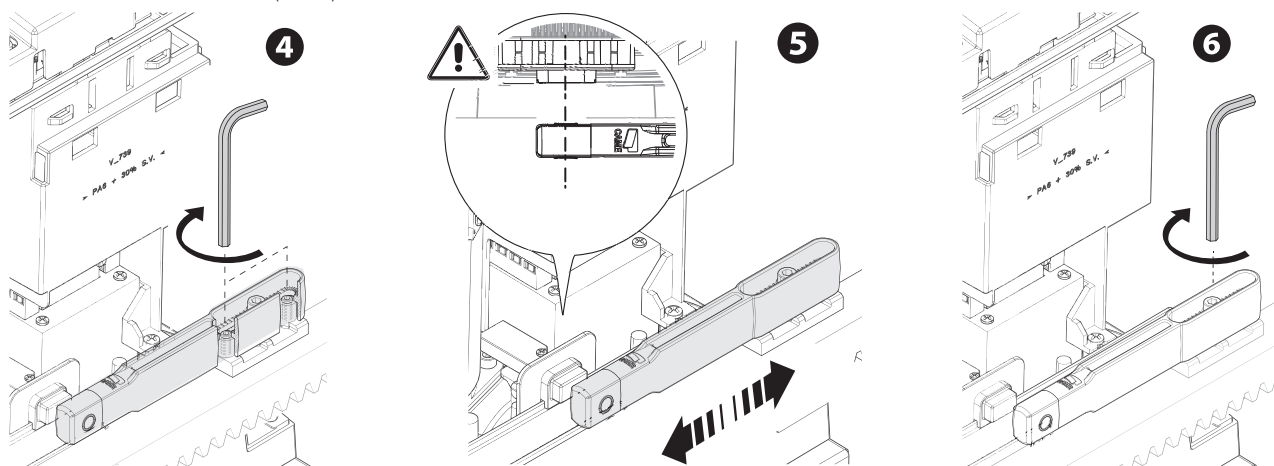

Passaggio dei cavi elettrici

Eseguire i collegamenti elettrici secondo le disposizioni vigenti.

I cavi elettrici non devono entrare in contatto con parti che possono riscaldarsi durante l'uso (per esempio: motore e trasformatore).

Utilizzare dei pressacavi per collegare i dispositivi al quadro comando. Uno di questi deve essere destinato esclusivamente per il cavo di alimentazione.

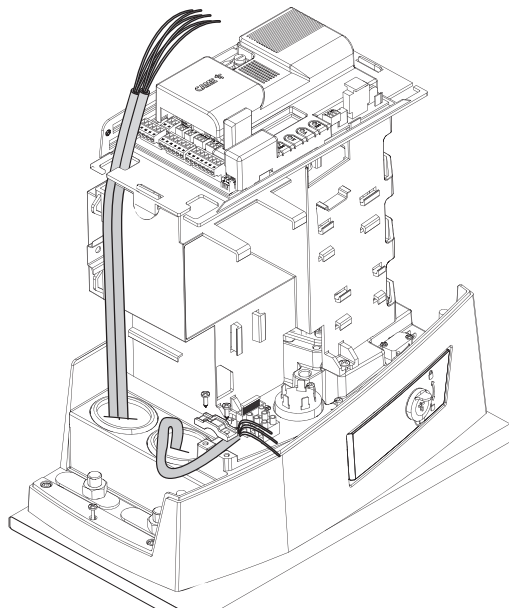
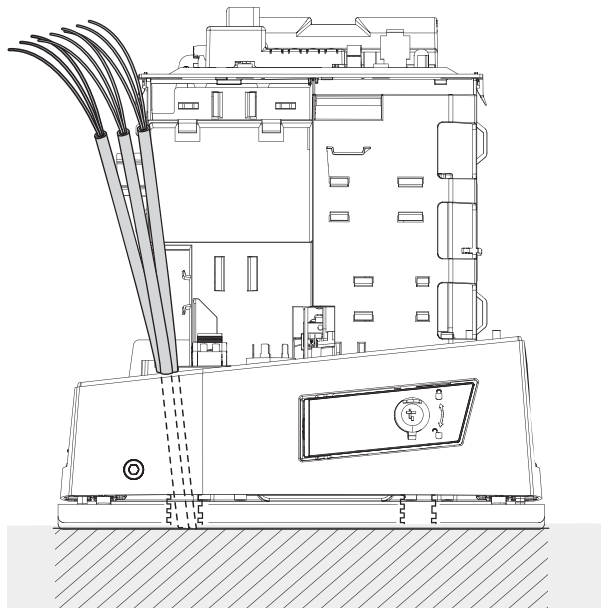

Alimentazione

Durante tutte le fasi dell'installazione assicurarsi di operare fuori tensione.

Prima di intervenire sul quadro di comando, togliere la tensione di linea e, se presenti, scollegare le batterie.

Collegamento alla rete elettrica (120/230 V AC - 50/60 Hz)

- Cavo di fase
- Cavo neutro
- Cavo di terra

Uscita alimentazione per accessori

L'uscita eroga normalmente 24 V AC.

La somma degli assorbimenti degli accessori connessi non deve superare i 20 W.

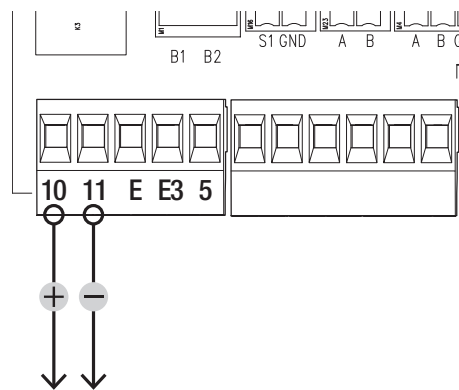
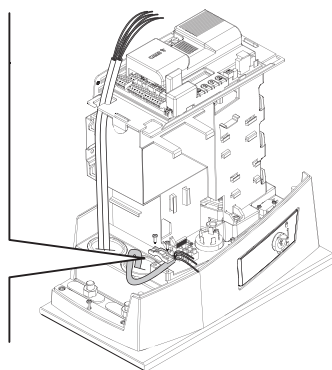
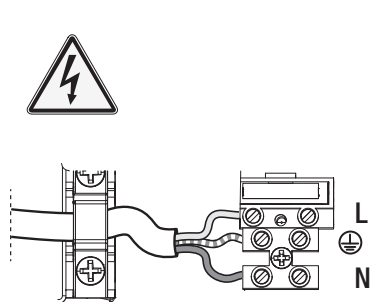

Portata massima dei contatti

Dispositivo	Uscita	Alimentazione (V)	Potenza (W)
Accessori	10 - 11	24 AC/DC	20
Lampada supplementare	10 - E3	24 AC/DC	12
Lampeggiatore	10 - E	24 AC/DC	3
Spia stato automazione	10 - 5	24 AC/DC	3

Rimuovere il coperchio di protezione della scheda elettronica.

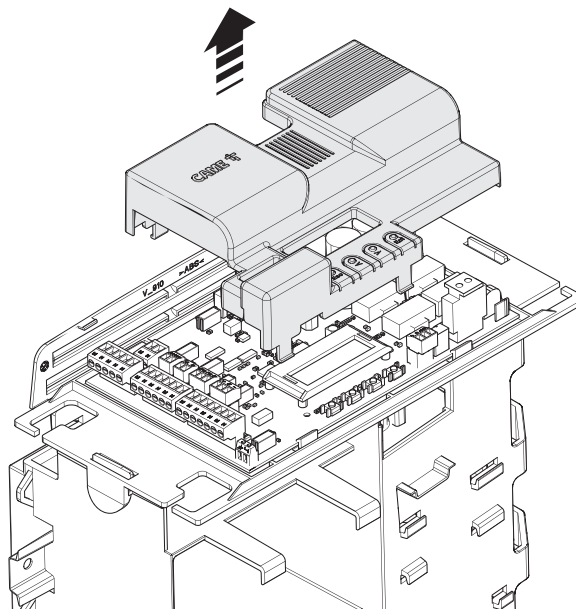
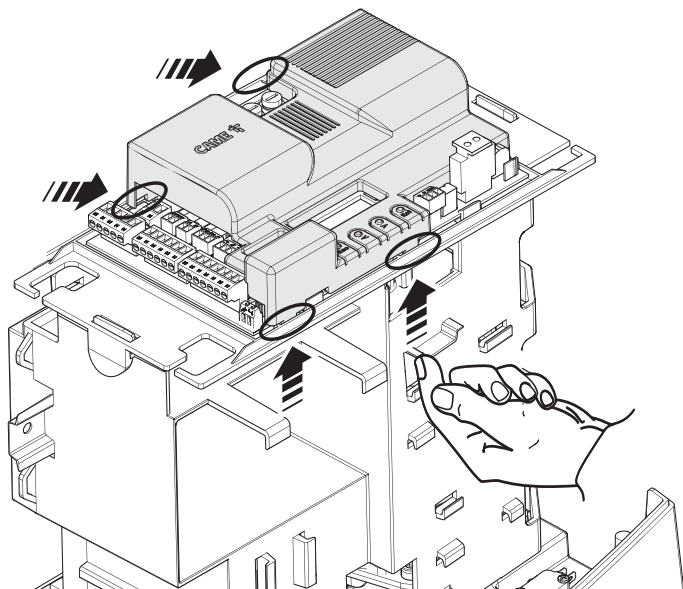

Dispositivi di segnalazione

1 Lampeggiatore

Lampeggia durante le fasi di apertura e chiusura dell'automazione.

2 Lampada supplementare

Aumenta l'illuminazione nella zona di manovra.

3 Spia stato automazione

Segnala lo stato dell'automazione.

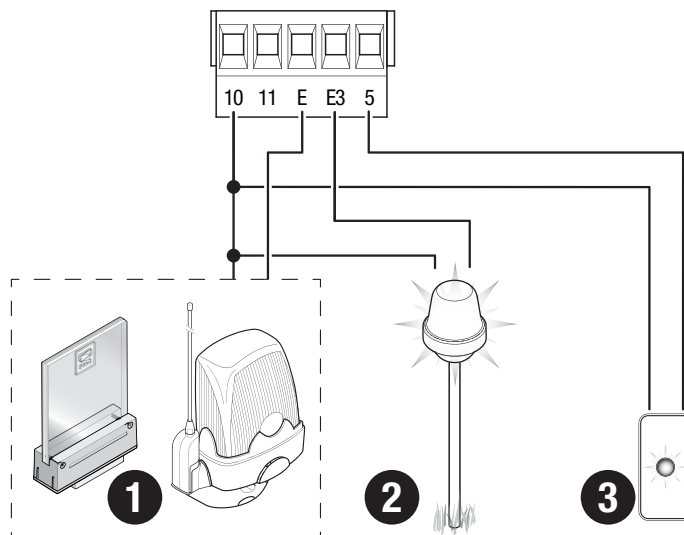

Dispositivi di comando

- 1 Lettore per tessere
- 2 Selettore transponder
- 3 Selettore a tastiera
- 4 Pulsante di STOP (contatto NC)

Arresta il cancello ed esclude l'eventuale chiusura automatica. Usare un dispositivo di comando per riprendere il movimento.

 Se il contatto non viene utilizzato, deve essere disattivato in fase di programmazione.

- 5 Dispositivo di comando (contatto NO)

Funzione SOLO APRE

- 6 Dispositivo di comando (contatto NO)

Funzione APERTURA PARZIALE

- 7 Dispositivo di comando (contatto NO)

Funzione SOLO CHIUDE

- 8 Dispositivo di comando (contatto NO)

Funzione APRE-CHIUDE (passo-passo) o APRE-STOP-CHIUDE-STOP (sequenziale)

- 9 Antenna con cavo RG58

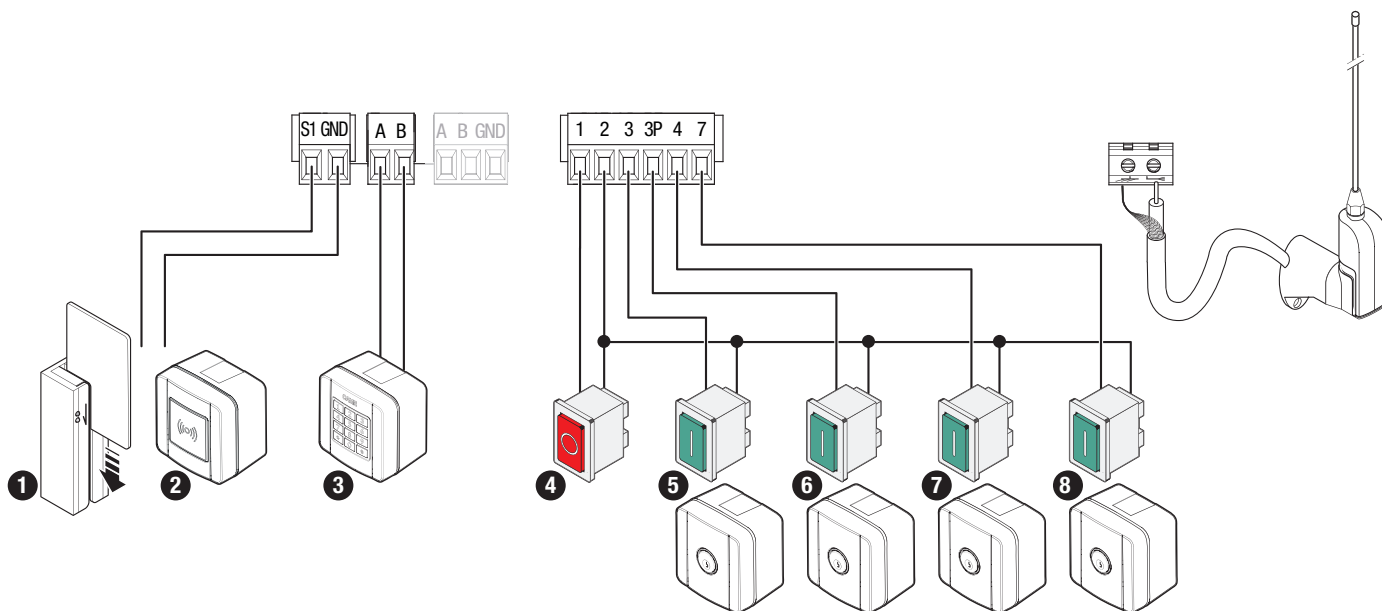

Dispositivi di sicurezza

Collegare i dispositivi di sicurezza agli ingressi CX, CY, CZ e/o CK (contatti NC).

In fase di programmazione, configurare il tipo di azione che deve essere svolta dal dispositivo collegato all'ingresso.

📖 Se non vengono utilizzati, i contatti CX, CY, CZ e/o CK devono essere disattivati in fase di programmazione.

Fotocelle DELTA

Collegamento standard

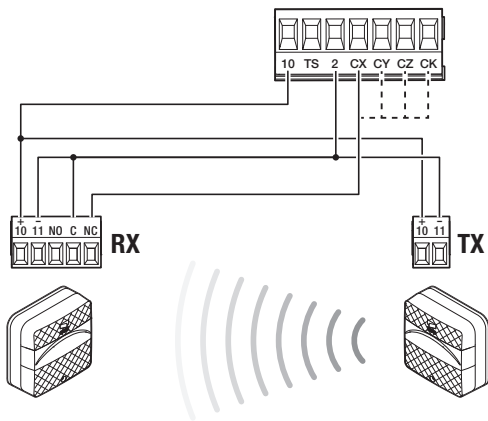

Fotocelle DELTA

Collegamento con test di sicurezza

📖 Vedi funzione F5 test sicurezza.

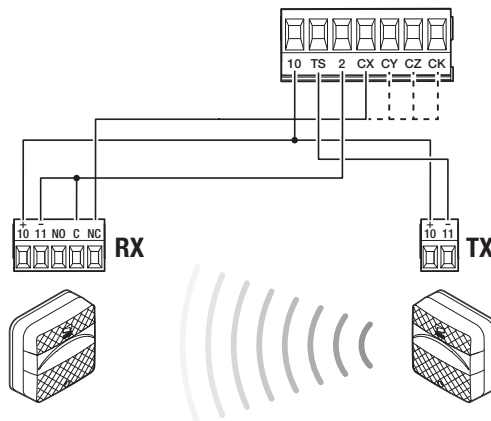

Fotocelle DIR / DELTA-S

Collegamento standard

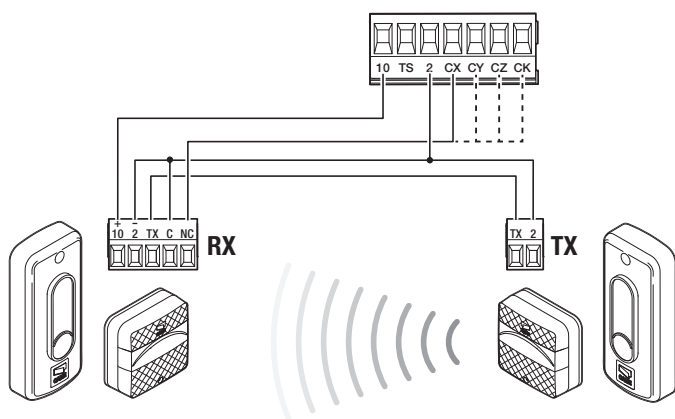

Fotocelle DIR / DELTA-S

Collegamento con test di sicurezza

📖 Vedi funzione F5 test sicurezza.

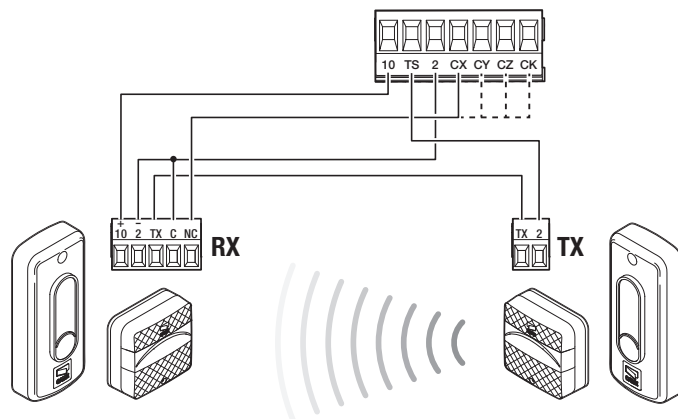

Bordo sensibile DFWN

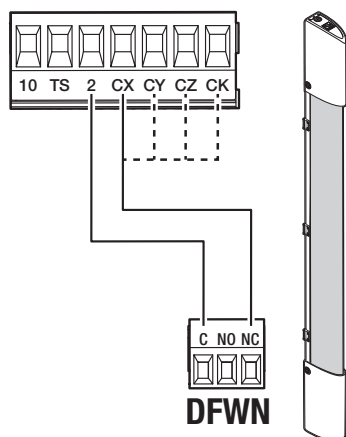

Coppia di bordi sensibili DFWN

Collegamento in parallelo (consigliato)

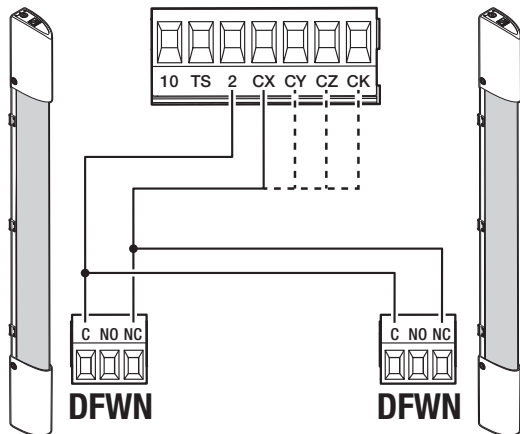

Coppia di bordi sensibili DFWN

Collegamento in serie

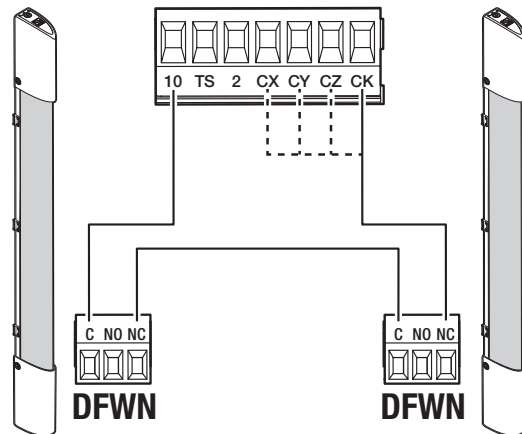

Funzione dei tasti di programmazione

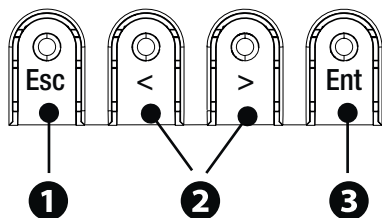

1 Tasto ESC

Il tasto ESC permette di eseguire le operazioni di seguito descritte.
 Uscire dal menu
 Annullare le modifiche
 Tornare alla schermata precedente
 Arrestare l'automazione

2 Tasti < >

I tasti < > permettono di eseguire le operazioni di seguito descritte.
 Navigare attraverso le voci del menu
 Incrementare o decrementare un valore
 Chiudere o aprire l'automazione

3 Tasto ENTER

Il tasto ENTER permette di eseguire le operazioni di seguito descritte.
 Entrare nei menu
 Confermare la scelta

Messa in funzione

Terminati i collegamenti elettrici, procedere con la messa in funzione. L'operazione deve essere effettuata solo da personale esperto e qualificato.
 Controllare che l'area di manovra sia libera da qualsiasi ostacolo.
 Dare tensione e procedere con la procedura guidata che appare a display.

Dopo aver dato tensione all'impianto, la prima manovra è sempre in apertura; attendere il completamento della manovra.

Premere immediatamente il pulsante di STOP se si riscontrano anomalie, malfunzionamenti, rumorosità o vibrazioni sospette o comportamenti inattesi dell'impianto.

Menu delle funzioni

Direzione apertura

Imposta la direzione di apertura del cancello.

Configurazione Impostazioni motore	Direzione apertura	Verso sinistra (Default) Verso destra
---------------------------------------	--------------------	--

Prova motore

Verifica del corretto senso di apertura del cancello.

Se i tasti non eseguono correttamente i comandi, invertire il senso di apertura del cancello.

Configurazione Impostazioni motore	Prova motore	Il tasto > fa chiudere il cancello Il tasto < fa aprire il cancello
---------------------------------------	--------------	--

Taratura corsa

Avvia l'auto-apprendimento della corsa.

Configurazione Impostazioni motore	Taratura corsa	Confermi? NO Confermi? SI
---------------------------------------	----------------	------------------------------

Tipo motore

Imposta il tipo di motoriduttore installato.

Configurazione Impostazioni motore	Tipo motore	BKV1500 BKV2000 BKV2500
---------------------------------------	-------------	-------------------------------

Velocità apertura

Imposta la velocità di apertura (percentuale della massima velocità).

Configurazione Impostazioni corsa	Velocità apertura	da 40% a 100% (Default 100%)
--------------------------------------	--------------------------	------------------------------

Velocità chiusura

Imposta la velocità di chiusura (percentuale della massima velocità).

Configurazione Impostazioni corsa	Velocità chiusura	da 40% a 100% (Default 100%)
--------------------------------------	--------------------------	------------------------------

Velocità di rallentamento in apertura

Imposta la velocità di rallentamento in apertura (percentuale della massima velocità).

Configurazione Impostazioni corsa	Velocità rall apertura	da 15% a 60% (50% Default)
--------------------------------------	-------------------------------	----------------------------

Velocità di rallentamento in chiusura

Imposta la velocità di rallentamento in chiusura (percentuale della massima velocità).

Configurazione Impostazioni corsa	Velocità rall chiusura	da 15% a 60% (50% Default)
--------------------------------------	-------------------------------	----------------------------

Sensibilità in corsa

Regolazione della sensibilità di rilevazione degli ostacoli durante la corsa.

Configurazione Impostazioni corsa	AST control corsa	Disattivato (Default) Minimo Medio Massimo Personalizzato
--------------------------------------	--------------------------	---

Sensibilità rallentamento

Regola il grado di sensibilità di rilevazione degli ostacoli durante la fase di rallentamento.

Configurazione Impostazioni corsa	AST control in rall	Disattivato (Default) Minimo Medio Massimo Personalizzato
--------------------------------------	----------------------------	---

Partenza rallentata

Per impostare un rallentamento di qualche secondo dopo ogni comando di apertura e di chiusura.

Configurazione Impostazioni corsa	Partenza rallentata	Disattivato (Default) Attivato
--------------------------------------	----------------------------	-----------------------------------

Punto di apertura parziale

Determina, in percentuale sulla corsa totale, il punto di apertura parziale del cancello.

Configurazione Impostazioni corsa	Punto ap. parziale	da 10% a 100% (20% Default)
--------------------------------------	---------------------------	-----------------------------

Punto di rallentamento in apertura

Imposta il punto di inizio del rallentamento in apertura (percentuale della corsa totale).

Configurazione Impostazioni corsa	Punto rall apertura	Da 10% a 60% (25% Default)
--------------------------------------	---------------------	----------------------------

Punto di rallentamento in chiusura

Imposta il punto di inizio del rallentamento in chiusura (percentuale della corsa totale).

Configurazione Impostazioni corsa	Punto rall chiusura	Da 10% a 60% (25% Default)
--------------------------------------	---------------------	----------------------------

Stop totale

Arresta il cancello ed esclude l'eventuale chiusura automatica. Usare un dispositivo di comando per riprendere il movimento.

Configurazione Sicurezze filari	Stop totale	Disattivato (Default) Attivato
------------------------------------	-------------	-----------------------------------

Ingresso CX

Associa una funzione all'ingresso CX.

Configurazione Sicurezze filari	Ingresso CX	Disattivato (Default) C1 = Riapertura durante la chiusura (Fotocellule) C2 = Richiusura durante l'apertura (Fotocellule) C3 = Stop parziale C4 = Attesa ostacolo (Fotocellule) C7 = Riapertura durante la chiusura (Bordi sensibili) C8 = Richiusura durante l'apertura (Bordi sensibili) C13 = riapertura durante la chiusura con chiusura immediata dopo la rimozione dell'ostacolo, anche con cancello non in movimento r7 = riapertura durante la chiusura (Bordi sensibili con resistenza 8K2) r8 = richiusura durante l'apertura (Bordi sensibili con resistenza 8K2) r7 (due bordi sensibili) = riapertura durante la chiusura (Coppia di bordi sensibili con resistenza 8K2) r8 (due bordi sensibili) = richiusura durante l'apertura (Coppia di bordi sensibili con resistenza 8K2)
------------------------------------	-------------	---

Ingresso CY

Associa una funzione all'ingresso CY.

Configurazione Sicurezze filari	Ingresso CY	Disattivato (Default) C1 = Riapertura durante la chiusura (Fotocellule) C2 = Richiusura durante l'apertura (Fotocellule) C3 = Stop parziale C4 = Attesa ostacolo (Fotocellule) C7 = Riapertura durante la chiusura (Bordi sensibili) C8 = Richiusura durante l'apertura (Bordi sensibili) C13 = riapertura durante la chiusura con chiusura immediata dopo la rimozione dell'ostacolo, anche con cancello non in movimento r7 = riapertura durante la chiusura (Bordi sensibili con resistenza 8K2) r8 = richiusura durante l'apertura (Bordi sensibili con resistenza 8K2) r7 (due bordi sensibili) = riapertura durante la chiusura (Coppia di bordi sensibili con resistenza 8K2) r8 (due bordi sensibili) = richiusura durante l'apertura (Coppia di bordi sensibili con resistenza 8K2)
------------------------------------	-------------	---

Ingresso CZ

Associa una funzione all'ingresso CZ.

Configurazione Sicurezze filari	Ingresso CZ	Disattivato (Default) C1 = Riapertura durante la chiusura (Fotocellule) C2 = Richiusura durante l'apertura (Fotocellule) C3 = Stop parziale C4 = Attesa ostacolo (Fotocellule) C7 = Riapertura durante la chiusura (Bordi sensibili) C8 = Richiusura durante l'apertura (Bordi sensibili) C13 = riapertura durante la chiusura con chiusura immediata dopo la rimozione dell'ostacolo, anche con cancello non in movimento r7 = riapertura durante la chiusura (Bordi sensibili con resistenza 8K2) r8 = richiusura durante l'apertura (Bordi sensibili con resistenza 8K2) r7 (due bordi sensibili) = riapertura durante la chiusura (Coppia di bordi sensibili con resistenza 8K2) r8 (due bordi sensibili) = richiusura durante l'apertura (Coppia di bordi sensibili con resistenza 8K2)
------------------------------------	--------------------	---

Ingresso CK

Associa una funzione all'ingresso CK.

Configurazione Sicurezze filari	Ingresso CK	Disattivato (Default) C1 = Riapertura durante la chiusura (Fotocellule) C2 = Richiusura durante l'apertura (Fotocellule) C3 = Stop parziale C4 = Attesa ostacolo (Fotocellule) C7 = Riapertura durante la chiusura (Bordi sensibili) C8 = Richiusura durante l'apertura (Bordi sensibili) C13 = riapertura durante la chiusura con chiusura immediata dopo la rimozione dell'ostacolo, anche con cancello non in movimento r7 = riapertura durante la chiusura (Bordi sensibili con resistenza 8K2) r8 = richiusura durante l'apertura (Bordi sensibili con resistenza 8K2) r7 (due bordi sensibili) = riapertura durante la chiusura (Coppia di bordi sensibili con resistenza 8K2) r8 (due bordi sensibili) = richiusura durante l'apertura (Coppia di bordi sensibili con resistenza 8K2)
------------------------------------	--------------------	---

Test sicurezze

Attiva il controllo del corretto funzionamento delle fotocellule collegate agli ingressi, dopo ogni comando di apertura e chiusura.

Configurazione Sicurezze filari	Test sicurezze	Disattivato (Default) Attivato
------------------------------------	-----------------------	-----------------------------------

Ostacolo a motore fermo

Con la funzione attiva, il cancello rimane fermo se i dispositivi di sicurezza rilevano un ostacolo. La funzione ha effetto con: cancello chiuso, cancello aperto o dopo uno stop totale.

Configurazione Sicurezze filari	Ost. a motore fermo	Disattivato (Default) Attivato
------------------------------------	----------------------------	-----------------------------------

RIO ED T1

Permette di associare una funzione tra quelle previste a un dispositivo di sicurezza wireless.

La funzione appare solo se è presente una scheda di interfaccia per dispositivi wireless.

Configurazione Sicurezze RIO	RIO ED T1	Disabilitata (Default) P0 = Arresta il cancello ed esclude l'eventuale chiusura automatica. Usare un dispositivo di comando per riprendere il movimento. P7 = Riapertura durante la chiusura. P8 = Richiusura durante l'apertura.
---------------------------------	------------------	--

RIO ED T2

Permette di associare una funzione tra quelle previste a un dispositivo di sicurezza wireless.

La funzione appare solo se è presente una scheda di interfaccia per dispositivi wireless.

Configurazione Sicurezze RIO	RIO ED T2	Disabilitata (Default) P0 = Arresta il cancello ed esclude l'eventuale chiusura automatica. Usare un dispositivo di comando per riprendere il movimento. P7 = Riapertura durante la chiusura. P8 = Richiusura durante l'apertura.
---------------------------------	------------------	--

RIO PH T1

Permette di associare una funzione tra quelle previste a un dispositivo di sicurezza wireless.

La funzione appare solo se è presente una scheda di interfaccia per dispositivi wireless.

Configurazione Sicurezze RIO	RIO PH T1	Disabilitata (Default) P1 = Riapertura durante la chiusura. P2 = Richiusura durante l'apertura. P3 = Stop parziale. P4 = Attesa ostacolo. P13 = riapertura durante la chiusura con chiusura immediata dopo la rimozione dell'ostacolo, anche con cancello non in movimento.
---------------------------------	------------------	--

RIO PH T2

Permette di associare una funzione tra quelle previste a un dispositivo di sicurezza wireless.

La funzione appare solo se è presente una scheda di interfaccia per dispositivi wireless.

Configurazione Sicurezze RIO	RIO PH T2	Disabilitata (Default) P1 = Riapertura durante la chiusura. P2 = Richiusura durante l'apertura. P3 = Stop parziale. P4 = Attesa ostacolo. P13 = riapertura durante la chiusura con chiusura immediata dopo la rimozione dell'ostacolo, anche con cancello non in movimento.
---------------------------------	------------------	--

Comando 2-7

Per l'associazione di un comando al dispositivo collegato su 2-7.

Configurazione Ingressi comando	Comando 2-7	Passo-passo (Default) Sequenziale
------------------------------------	--------------------	--------------------------------------

Azione mantenuta

Con la funzione attiva, il movimento dell'automazione (apertura o chiusura) si interrompe quando il dispositivo di comando viene rilasciato.

 L'attivazione della funzione esclude tutti gli altri dispositivi di comando.

Configurazione Funzioni	Azione mantenuta	Disattivato (Default) Attivato
----------------------------	-------------------------	-----------------------------------

Uscita B1-B2

Per la configurazione del contatto.

Configurazione Funzioni	Uscita B1-B2	Bistabile (Default) Monostabile Il contatto rimane chiuso da 1 a 180 secondi.
----------------------------	---------------------	---

Libera ostacolo

In caso di ostacolo rilevato dal bordo sensibile o dal sensore amperometrico della scheda elettronica, avviene l'inversione di marcia per uno spazio sufficiente a liberare l'ostacolo.

Con funzione disattivata, avviene l'inversione di marcia fino al raggiungimento del finecorsa.

Configurazione Funzioni	Libera ostacolo	Disattivato (Default) Attivato
-------------------------	-----------------	-----------------------------------

Chiusura automatica

Imposta il tempo che deve trascorrere prima che si attivi la chiusura automatica, una volta che è stato raggiunto il punto di finecorsa in apertura.

 La funzione non si attiva nei casi in cui: intervengano dispositivi di sicurezza per la rilevazione di un ostacolo, dopo uno stop totale o in caso di mancanza di tensione.

Configurazione Tempi	Ch. Automatica	Disattivato (Default) Da 1 a 180 secondi
----------------------	----------------	---

Chiusura automatica dopo apertura parziale

Imposta il tempo che deve trascorrere prima che si attivi la chiusura automatica, dopo che è stato eseguito un comando di apertura parziale.

 La funzione non si attiva nei casi in cui: intervengano dispositivi di sicurezza per la rilevazione di un ostacolo, dopo uno stop totale o in caso di mancanza di tensione.

 Non disattivare la funzione [Ch. automatica].

Configurazione Tempi	Ch. auto. parziale	Disattivato Da 1 a 180 secondi (10 secondi Default)
----------------------	--------------------	--



Spia cancello aperto

Segnala lo stato del cancello.

Configurazione Gestione lampade	Spia cancello aperto	Spia accesa (Default) - La spia rimane accesa quando il cancello è in movimento o aperto. Spia lampeggiante - La spia lampeggia quando il cancello è in movimento e rimane accesa quando il cancello è aperto.
---------------------------------	----------------------	---

Lampada E3

Permette di scegliere la modalità di funzionamento del dispositivo di illuminazione collegato all'uscita.

Configurazione Gestione lampade	Lampada E3	Disattivato (Default) Lampada ciclo  La lampada rimane spenta se non viene impostato un tempo di chiusura automatica. Lampada di cortesia  La lampada rimane accesa per il tempo impostato con la funzione [Tempo cortesia].
---------------------------------	------------	--

Tempo cortesia

Imposta il tempo di accensione del dispositivo di illuminazione.

Configurazione Gestione lampade	Tempo cortesia	da 60 a 180 secondi (60 secondi Default)
---------------------------------	----------------	--

Tempo prelampeggio

Imposta il tempo di attivazione anticipata del lampeggiatore, prima di ogni manovra.

Configurazione Gestione lampade	Tempo prelampeggio	Disattivato (Default) Da 1 a 10 secondi
---------------------------------	--------------------	--

RSE1

Configura la funzione che deve svolgere la scheda innestata sul connettore RSE1.

 Se sul connettore RSE_1 è presente una scheda RSE configurata per il collegamento abbinato, utilizzare il connettore RSE_2 per la connessione remota (CRP). In questo caso, viene esclusa la possibilità di collegare CAME KEY.

Configurazione Comunicazione RSE	RSE1	CRP (Default) Abbinato Disattivato
-------------------------------------	-------------	--

Indirizzo CRP

Assegna un codice identificativo univoco (indirizzo CRP) alla scheda elettronica. La funzione è necessaria nel caso ci siano più automazioni connesse mediante CRP.

Configurazione Comunicazione RSE	Indirizzo CRP	da 1 a 254
-------------------------------------	----------------------	------------

Velocità RSE1

Imposta la velocità di comunicazione del sistema di connessione remota sulla porta RSE1.

Configurazione Comunicazione RSE	Velocità RSE1	1200 bps 2400 bps 4800 bps 9600 bps 14400 bps 19200 bps 38400 bps (Default) 57600 bps 115200 bps
-------------------------------------	----------------------	--

Velocità RSE2

Imposta la velocità di comunicazione del sistema di connessione remota sulla porta RSE2.

Configurazione Comunicazione RSE	Velocità RSE2	1200 bps 2400 bps 4800 bps 9600 bps 14400 bps 19200 bps 38400 bps (Default) 57600 bps 115200 bps
-------------------------------------	----------------------	--

Salvataggio dati

Salva nel dispositivo di memoria (memory roll o chiave USB) i dati relativi agli utenti, alle temporizzazioni e alle configurazioni.

 La funzione viene visualizzata solo quando viene inserita una chiavetta nella porta USB o quando viene inserita una memory roll nella scheda elettronica.

Configurazione Memoria esterna	Salvataggio dati	
-----------------------------------	-------------------------	--

Letture dati

Carica dal dispositivo di memoria (memory roll o chiave USB) i dati relativi agli utenti, alle temporizzazioni e alle configurazioni.

 La funzione viene visualizzata solo quando viene inserita una chiavetta nella porta USB o quando viene inserita una memory roll nella scheda elettronica.

Configurazione Memoria esterna	Letture dati	
-----------------------------------	---------------------	--

Nuovo Utente

Permette di registrare un massimo di 250 utenti e di assegnare ad ognuno di essi una funzione.

 L'operazione può essere svolta mediante un trasmettitore o altro dispositivo di comando. Le schede che gestiscono i dispositivi di comando (AF - R700 - R800) devono essere innestate nei connettori.

Gestione utenti	Nuovo Utente	Passo passo Sequenziale Apri Apertura parziale Uscita B1-B2 Scegliere la funzione che si vuole assegnare all'utente. Premere ENTER per confermare. Inviare il codice dal dispositivo di comando. Ripetere la procedura per inserire altri utenti.
-----------------	---------------------	---

Rimuovi utente

Rimuove uno degli utenti registrati.

Gestione utenti	Rimuovi utente	Usare le frecce per scegliere il numero associato all'utente che si vuole rimuovere. Nr: 1 > 250 In alternativa è possibile azionare il dispositivo di comando associato all'utente che si vuole rimuovere. Premere ENTER per confermare. Appare la scritta CLR a confermare la cancellazione. Confermi? NO Confermi? SI
-----------------	-----------------------	--

Rimuovi tutti

Rimuove tutti gli utenti registrati.

Gestione utenti	Rimuovi tutti	Confermi? NO Confermi? SI
-----------------	----------------------	------------------------------

Decodifica radio

Permette di scegliere il tipo di codifica radio dei trasmettitori abilitati a comandare l'automazione.

 Scegliendo il tipo di codifica radio dei trasmettitori [Rolling code] o [TW key block], eventuali trasmettitori con codifica radio diversa precedentemente memorizzati, verranno cancellati.

Gestione utenti	Decodifica radio	Tutte le decodifiche Rolling code TW Key block Confermi? NO Confermi? SI
-----------------	-------------------------	--

Tipo sensore

Imposta il tipo di dispositivo di comando.

Gestione utenti	Tipo sensore	Tastiera Transponder
-----------------	---------------------	-------------------------

Cambio modalità

Cambia la funzione assegnata ad un determinato utente.

Gestione utenti	Cambio modalità	Selezionare l'utente di cui si vuole modificare il comando. È possibile selezionare l'utente senza usare le frecce, inviando un comando dal dispositivo associato all'utente. Premere ENTER per confermare. Scegliere il comando da associare all'utente. Premere ENTER per confermare. Confermi? No Confermi? Si
-----------------	-----------------	---

Versione FW

Visualizza il numero della versione firmware e GUI installate.

Informazioni	Versione FW	FW x.x.xx (firmware) GUI x.x (grafica)
--------------	-------------	---

Conteggi manovre

Permette di visualizzare il numero di manovre effettuate dall'automazione.

Manovre totali = Manovre effettuate dal momento dell'installazione.

Manovre parziali = Manovre effettuate dopo l'ultimo [Reset parametri].

Informazioni	Conteggi manovre	Manovre totali Manovre parziali
--------------	------------------	------------------------------------

Setta manutenzione

Permette di impostare il numero di manovre che può eseguire l'automazione, prima che venga generato un segnale che avvisa della necessità di effettuare la manutenzione. Il segnale consiste nel lampeggio ritmico 3 + 3 volte, ogni ora, della spia [Apre].

Informazioni	Setta manutenzione	Disattivato (Default) da 1X100 a 250X100
--------------	--------------------	---

Reset manutenzione

Azzerare il conteggio del numero delle manovre parziali.

Informazioni	Reset manutenzione	Confermi? NO Confermi? SI
--------------	--------------------	------------------------------

Reset parametri

Ripristina le impostazioni di fabbrica ad esclusione delle funzioni: [Decodifica radio], [Tipo motore] e le impostazioni relative alla taratura della corsa.

Informazioni	Reset parametri	Confermi? NO Confermi? SI
--------------	-----------------	------------------------------

Lista errori

Visualizza gli ultimi 8 errori rilevati. La lista errori può essere cancellata.

Informazioni	Lista errori	Usare le frecce per scorrere la lista. Per cancellare la lista errori selezionare [Cancella errori] Premere ENTER per confermare. Confermi? NO Confermi? SI
--------------	--------------	---

Mostra orologio

Abilita la visualizzazione dell'orologio sul display.

Gestione timer	Mostra orologio	
----------------	-----------------	--

Imposta orologio

Permette di impostare data e ora.

Gestione timer	Imposta orologio	Utilizzare le frecce ed il pulsante Enter per inserire i valori desiderati.
----------------	------------------	---

DST automatico

Abilita l'impostazione automatica dell'ora legale.

Gestione timer	DST automatico	Disattivato (Default) Attivato
----------------	----------------	-----------------------------------

Formato ora

Permette di scegliere il formato di visualizzazione dell'orologio.

Gestione timer	Formato ora	24 ore 12 ore (AM/PM)
----------------	-------------	--------------------------

Crea nuovo timer

Permette di temporizzare una o più tipologie di attivazioni a scelta tra quelle disponibili.

Gestione timer	Crea nuovo timer	Usare le frecce per scegliere la funzione desiderata. Apertura / Apertura parziale/Uscita B1-B2 Premere ENTER per confermare. Usare le frecce per impostare l'ora di inizio e l'ora di fine dell'attivazione della funzione. Orario inizio / Orario fine Premere ENTER per confermare. Usare le frecce per impostare i giorni di attivazione della funzione. Seleziona giorni / Tutta settimana Premere ENTER per confermare.
----------------	------------------	---

Rimuovi timer

Rimuove una delle temporizzazioni salvate.

Gestione timer	Rimuovi timer	Usare le frecce per scegliere la temporizzazione che si desidera rimuovere. 0 = [Apertura] P = [Apertura parziale] B = [Uscita B1-B2] Premere ENTER per confermare.
----------------	---------------	---

Comandi

Permette di far eseguire alcuni comandi al cancello senza l'ausilio di dispositivi di comando.

Comandi		Apertura Apertura parziale Chiusura Stop Usare le frecce per selezionare il comando che si vuole eseguire. Premere ENTER per confermare.
---------	--	---

Lingua

Imposta la lingua del display.

Lingua		Italiano (IT) English (EN) Français (FR) Deutsch (DE) Español (ES) Português (PT) Polski (PL) Русский (RU)
--------	--	---

Abilita password

Permette di impostare una password di 4 cifre. La password sarà richiesta a chiunque voglia accedere al menu principale.

Password	Abilita password	Utilizzare le frecce e il pulsante Enter per comporre il codice desiderato. Ripetere la password utilizzando le frecce e il tasto Enter per confermare.
----------	------------------	--

Smarrimento password

In caso di smarrimento della password, eseguire le operazioni di seguito descritte.

Togliere l'alimentazione alla scheda elettronica.

Tenendo premuti i tasti < >, ridare tensione alla scheda elettronica.

Continuare a tenere premuti i tasti < > fino a quando appare a display [Reset fabbrica].

Selezionare [Confermi? SI].

Premere ENTER per confermare.

 Ripristinando la scheda elettronica, vengono cancellati tutti gli utenti memorizzati, le temporizzazioni impostate e le operazioni di taratura.

Rimuovi password

Rimuove la password che protegge l'accesso al menu principale.

Password	Rimuovi password	Confermi? NO Confermi? SI
----------	------------------	------------------------------

Cambia password

Permette di cambiare la password di 4 cifre che protegge l'accesso al menu principale.

Password	Cambia password	Utilizzare le frecce ed il pulsante Enter per comporre il codice desiderato. Ripetere la password utilizzando le frecce e il tasto Enter per confermare.
----------	-----------------	---

Menu F

Abilita la vista del menu funzioni F.

Esportare / importare dati

È possibile salvare i dati relativi agli utenti e alla configurazione dell'impianto in una scheda MEMORY ROLL.

I dati memorizzati possono essere riutilizzati in un'altra scheda elettronica per configurare allo stesso modo un altro impianto.

⚠ Prima di inserire ed estrarre la scheda MEMORY ROLL, è **OBBLIGATORIO TOGLIERE LA TENSIONE DI LINEA**.

- 1 Inserire la scheda MEMORY ROLL sul connettore dedicato presente sulla scheda elettronica.
- 2 Premere il pulsante Enter per accedere alla programmazione.
- 3 Usare le frecce per scegliere la funzione desiderata.

📖 Le funzioni vengono visualizzate solo quando viene inserita una scheda MEMORY ROLL.

- Salvataggio dati

Salva nel dispositivo di memoria (memory roll o chiave USB) i dati relativi agli utenti, alle temporizzazioni e alle configurazioni.

- Lettura dati

Carica dal dispositivo di memoria (memory roll o chiave USB) i dati relativi agli utenti, alle temporizzazioni e alle configurazioni.

📖 Terminate le operazioni di salvataggio e caricamento dati, rimuovere la scheda MEMORY ROLL.

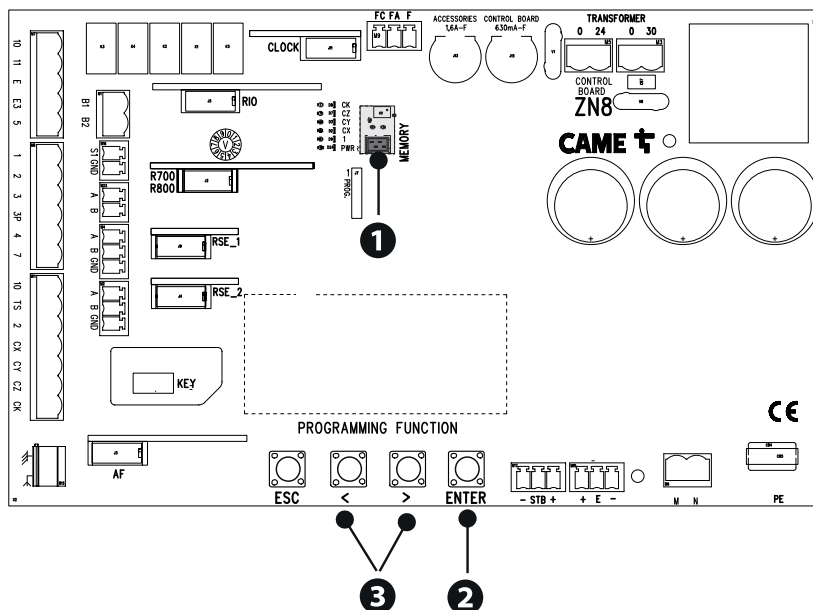

MESSAGGI DI ERRORE

Errore di calibrazione	Interruzione della taratura della corsa per la presenza di un ostacolo.
Encoder non funziona	L'Encoder è scollegato. L'Encoder è rotto.
Errore di test servizi fallito	Presenza di un ostacolo nel raggio d'azione delle fotocellule. Le fotocellule non sono collegate o configurate correttamente. Le fotocellule sono rotte.
Sportello aperto	L'automazione è sbloccata.
Nr massimo ostacoli in chiusura	Superato il numero massimo di ostacoli rilevati consecutivamente
Nr massimo ostacoli in apertura	Superato il numero massimo di ostacoli rilevati consecutivamente
Errore massimo di ostacoli	Superato il numero massimo di ostacoli rilevati consecutivamente
Errore comunicazione	La configurazione sulla porta RSE è errata.
Radiocomando non compatibile	Il trasmettitore usato non è CAME. La codifica impostata è diversa rispetto a quella del trasmettitore. I trasmettitori sono TWIN e hanno KEY BLOCK differenti.
Sportello SLAVE aperto	L'automazione SLAVE è sbloccata.
Sistema RIO non comunica	Il modulo wireless non è inserito sul connettore della scheda elettronica. Il modulo wireless è rotto.
Sistema RIO non configurato	Il modulo wireless non è stato configurato. I dispositivi wireless non sono stati configurati.

OPERAZIONI FINALI

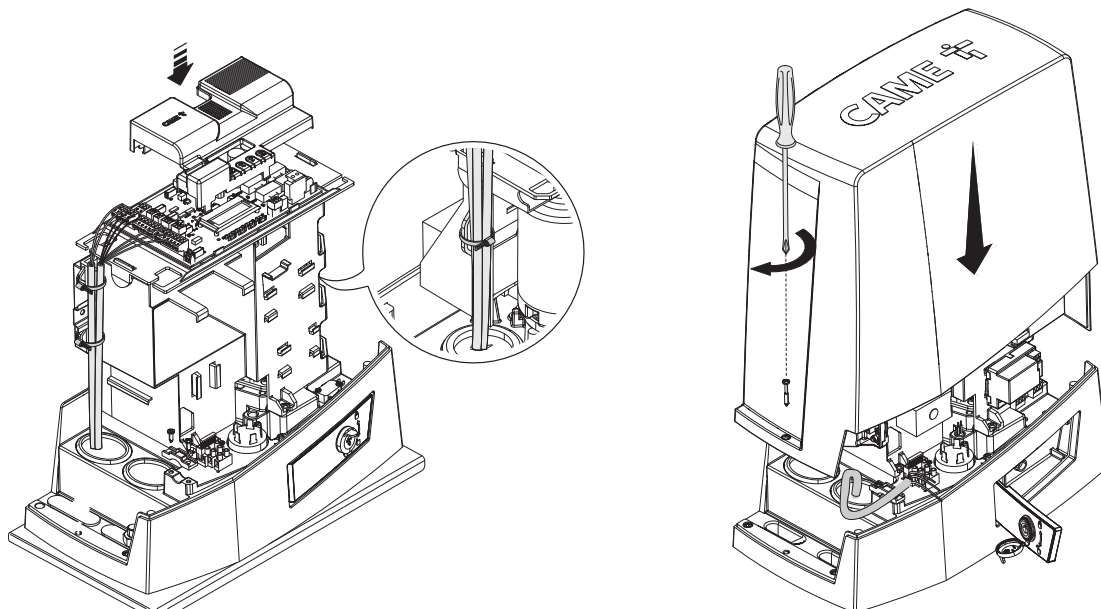

FUNZIONAMENTO ABBINATO

Comando unico di due automazioni collegate.

Collegamenti elettrici

Collegare le due schede elettroniche con un cavo tipo UTP CAT 5.

Inserire una scheda RSE su entrambe le schede elettroniche, utilizzando il connettore RSE_1.

Procedere con il collegamento elettrico dei dispositivi e degli accessori.

 I dispositivi e gli accessori vanno collegati sulla scheda elettronica che verrà impostata come MASTER.

 Per i collegamenti elettrici dei dispositivi e degli accessori, vedere capitolo COLLEGAMENTI ELETTRICI.

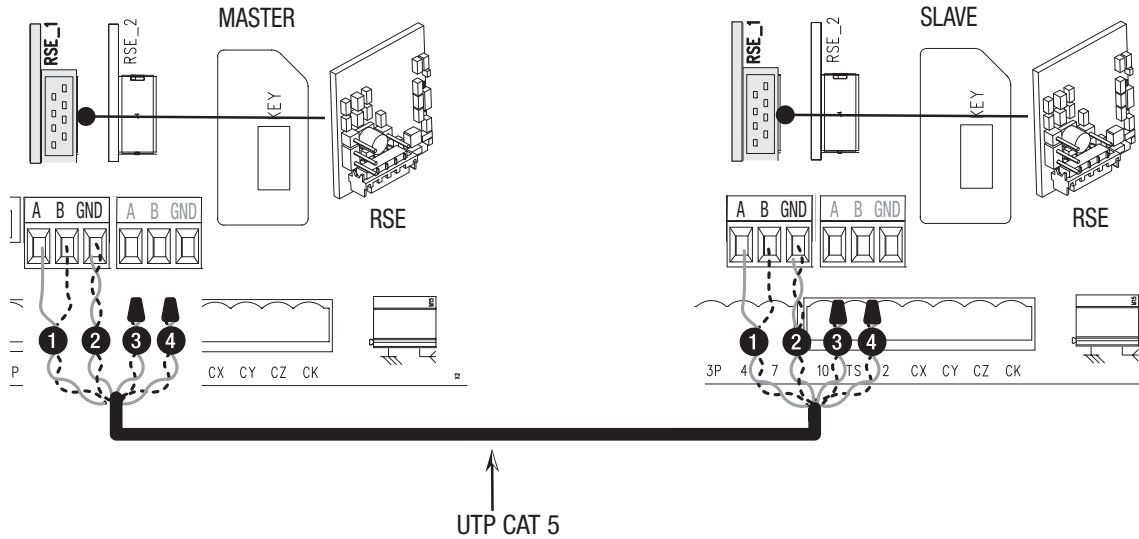

Programmazione

 Tutte le operazioni di programmazione di seguito descritte vanno eseguite solo sulla scheda elettronica impostata come MASTER. Selezionare il tipo di impianto [Abbinato] durante la procedura guidata o configurare la porta RSE_1 in [Abbinato].

 Dopo la programmazione dell'automazione MASTER in [Abbinato], la seconda automazione diventa automaticamente SLAVE.

Memorizzazione degli utenti

 Tutte le operazioni di memorizzazione degli utenti vanno eseguite solo sulla scheda elettronica impostata come MASTER.

Modalità di funzionamento

- 1 Comando APERTURA PARZIALE
- 2 Comando PASSO-PASSO o SOLO APRE

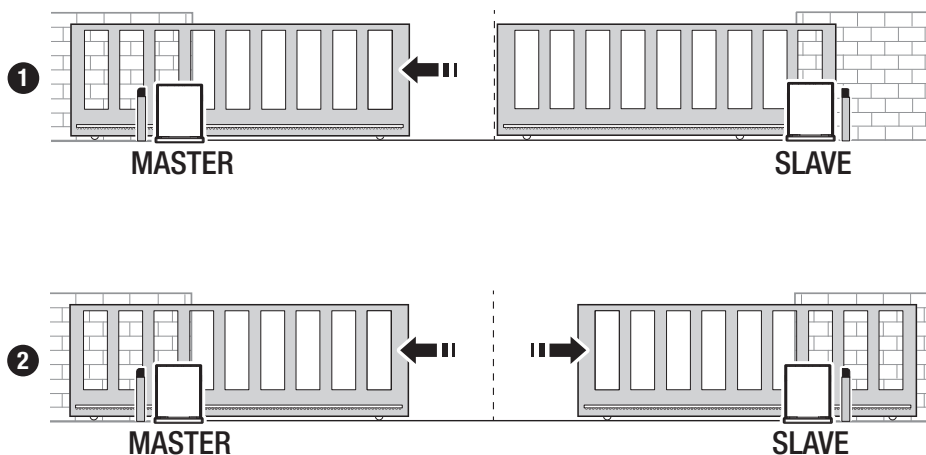

MCBF

Modelli	BKV15	BKV20	BKV25
20 m - 1500 kg	250000	-	-
20 m - 2000 kg	-	250000	-
20 m - 2500 kg	-	-	250000
Installazione in zona ventosa	-15%	-15%	-15%

 Le percentuali indicano di quanto si debba ridurre il numero di cicli in relazione al tipo e numero di accessori installati.

 Prima di effettuare qualunque operazione di pulizia, manutenzione o sostituzione di parti, togliere l'alimentazione al dispositivo.

 Questo documento fornisce all'installatore le indicazioni sui controlli obbligatori durante gli interventi di manutenzione.

 Se l'impianto non viene utilizzato per lunghi periodi, per esempio nel caso di installazioni in luoghi ad apertura stagionale, è opportuno togliere l'alimentazione e, al ripristino, verificare il corretto funzionamento.

 Per le informazioni relative alla corretta installazione e alle regolazioni, consultare il manuale di installazione del prodotto.

 Per le informazioni relative alla scelta del prodotto e degli accessori, consultare il catalogo prodotti.

 Ogni 10.000 cicli e comunque ogni 6 mesi di attività, sono obbligatori gli interventi di manutenzione di seguito indicati.

Eseguire un controllo generale e completo del serraggio della bulloneria.

Lubrificare tutte le parti meccaniche in movimento.

Controllare il buon funzionamento dei dispositivi di segnalazione e di sicurezza.

Controllare lo stato di usura delle parti meccaniche in movimento e verificarne il corretto funzionamento.

Controllare l'efficienza del dispositivo di sblocco, eseguendo una manovra con anta libera. L'anta non deve trovare impedimenti.

Verificare l'integrità dei cavi e le loro connessioni.

Controllare e pulire la guida di scorrimento e la cremagliera.

Fabbricante / Manufacturer / Hersteller / Fabricant / Fabricante / Fabricante
/ Wytwórca / Fabrikant

Came S.p.a.

indirizzo / address / adresse / adresse / direccìon / endereço / adres / adres
Via Martiri della Libertà 15 - 31030 Dosson di Casier, Treviso - Italy



DICHIARA CHE LE AUTOMAZIONI PER CANCELLI SCORREVOLI / DECLARES THAT THE DRIVES FOR SLIDING GATES /
ERKLÄRT DASS DIE AUTOMATISIERUNGEN FÜR SCHIEBETÖRE / DECLARE QUE LES AUTOMATISATIONS POUR
PORTAILS COULISSANTS / DECLARA QUE LAS AUTOMATIZACIONES PARA PUERTAS CORREDERAS / DECLARA QUE AS
AUTOMATIZAÇÕES PARA PORTÕES DE CORRER / OSWADCZA ZE AUTOMATYKA DO BRAM PRZESUWNYCH /
VERKLAART DAT DE AUTOMATISERING VOOR SCHUIFHEKKEN

BKV15AGS ; BKV20AGS ; BKV25AGS
BKV15ALS ; BKV20ALS ; BKV25ALS
BKV15RGS ; BKV20RGS ; BKV15AGE
BKV20AGE ; BKV25AGE

SONO CONFORMI ALLE DISPOSIZIONI DELLE SEGUENTI DIRETTIVE / THEY COMPLY WITH THE PROVISIONS OF THE FOLLOW-
ING DIRECTIVES / DEN VORGABEN DER FOLGENDEN RICHTLINIEN ENTSPRECHEN / SONT CONFORMES AUX DISPOSITIONS
DES DIRECTIVES SUIVANTES / CUMPLEN CON LAS DISPOSICIONES DE LAS SIGUIENTES DIRECTIVAS / ESTÃO DE ACORDO
COM AS DISPOSIÇÕES DAS SEQUENTES DIRECTIVAS / SA ZGODNE Z POSTANOWIENIAMI NASTĘPUJĄCYCH DYREKTYW
EUROPEJSKICH / VOLDOEN AAN DE VOORSCHRIFTEN VAN DE VOLGENDE RICHTLIJNEN:

- COMPATIBILITA' ELETTROMAGNETICA / ELECTROMAGNETIC COMPATIBILITY / ELEKTROMAGNETISCHE
VERTRÄGLICHKEIT / COMPATIBILITE ÉLECTROMAGNETIQUE / COMPATIBILIDAD ELECTROMAGNETICA / COMPATIBIL-
DADE ELETROMAGNETICA / KOMPATYBILNOŚCI ELEKTROMAGNETYCZNEJ / ELEKTROMAGNETISCHE COMPATIBI-
LITEIT : 2014/30/UE.

Riferimento norme armonizzate ed altre norme tecniche / Refer to
European regulations and other technical regulations / Harmonisierte
Bezugsnormen und andere technische Vorgaben / Référence aux normes
harmonisées et aux autres normes techniques / Referencia normas
armonizadas y otras normas técnicas / Referência de normas harmoniza-
das e outras normas técnicas / Odnosne normy ujednoliconé i inne normy
techniczne / Geharmoniseerde en andere technische normen waarnaar is
verwezen

EN 61000-6-2:2005
EN 61000-6-3:2007+A1:2011
EN 62233:2008
EN 60335-1:2012+A11:2014
EN 60335-2-103:2015

RISPETTANO I REQUISITI ESSENZIALI APPLICATI: / MEET THE APPLICABLE ESSENTIAL REQUIREMENTS: / DEN WESENTLIJEN
ANGEWANDTEN ANFORDERUNGEN ENTSPRECHEN: / RESPECTENT LES CONDITIONS REQUISES NECESSAIRES APPLIQUEES:
/ CUMPLEN CON LOS REQUISITOS ESSENCIALES APLICADOS: / RESPETAM O REQUISITOS ESSENCIAIS APLICADOS: /
SPEŁNIAJĄ PODSTAWOWE WYMAGANIA WYRUNKI: / VOLDOEN AAN DE TOEPASBARE MINIMUM EISEN:

1.1.3; 1.1.5; 1.2.1; 1.2.2; 1.3.2; 1.3.7; 1.3.8.1; 1.4.1; 1.4.2; 1.5.1; 1.5.6; 1.5.8; 1.5.9; 1.5.9; 1.5.13; 1.6.1; 1.6.3; 1.6.4;
1.7.1; 1.7.2; 1.7.4

PERSONA AUTORIZZATA A COSTITUIRE LA DOCUMENTAZIONE TECNICA PERTINENTE / PERSON AUTHORISED TO COMPILE THE RELEVANT TECHNICAL DOCUMENTATION /
PERSON DIE BEVOLLMÄCHTIGT IST, DIE RELEVANTEN TECHNISCHEN UNTERLAGEN ZUSAMMENZUSTELLEN / DOCUMENTATION TECHNIQUE SPECIFIQUE D'AUTORISATION
A CONSTRUIRE DE / PERSONA FACULTADA PARA ELABORAR LA DOCUMENTACIÓN TÉCNICA PERTINENTE / PESSOA AUTORIZADA A CONSTITUIR A DOCUMENTAÇÃO TÉCNICA
PERTINENTE / OSOBA UPOWAZNIONA DO ZREDAGOWANIA DOKUMENTACJI TECHNICZNEJ / DIEGENE DIE GEMACHTIGT IS DE RELEVANTE TECHNISCHE DOCUMENTEN
SAMEN TE STELLEN.

CAME S.p.a.

La documentazione tecnica pertinente è stata compilata in conformità all'allegato VIB. / The pertinent technical documentation has been drawn up in compliance with attached
document VIB. / Die relevante technische Dokumentation wurde entsprechend der Anlage VIB ausgestellt. / La documentation technique spécifique a été remplie conformément à
l'annexe VIB. / La documentación técnica pertinente ha sido rellenada en cumplimiento con el anexo VIB. / A documentação técnica pertinente foi preenchida de acordo com o anexo
VIB. / Odnosna dokumentacja techniczna została zredagowana zgodnie z załącznikiem VIB. / De technische documentatie terzake is opgesteld in overeenstemming met de bijlage VIB.

CAME S.p.a. si impegna a trasmettere, in risposta a una richiesta adeguatamente motivata delle autorità nazionali, informazioni pertinenti sulle quasi macchine, e / Came S.p.a., following
a duly motivated request from the national authorities, undertakes to provide information related to the quasi machines, and / Die Firma Came S.p.a. verpflichtet sich auf eine angemessen
motiviert Anfrage der staatlichen Behörden Informationen über die unvollständigen Maschinen, zu übermitteln, und / Came S.p.a. s'engage à transmettre, en réponse à une demande
bien fondée de la part des autorités nationales, les renseignements relatifs aux quasi machines / Came S.p.a. se compromete a transmitir, como resposta a una solicitud adecuadamente
fundada por parte de las autoridades nacionales, informaciones relacionadas con las cuasimáquinas / Came S.p.a. compromete-se em transmitir, em resposta a uma solicitação motivada
apropriadamente pelas autoridades nacionais, informações pertinentes às partes que compoñam máquinas / Came S.p.a. zobowiązuje się do udzielenia informacji dotyczących maszyn
nieukonczonych na odpowiednio umotywowana prośbę, złożoną przez kompetentne organy państwowe / Came S.p.a. verbindt zich ertoe om op met redenen omkleed verzoek van de
nationale autoriteiten de relevante informatie voor de niet voltooidde machine te verstrekken.

VIETA / FORBIDS / VERBIETET / INTERDIT / PROHIBE / PROIBE / ZABRANIA SIE / VERBIEDT

la messa in servizio finché la macchina finale in cui deve essere incorporata non è stata dichiarata conforme, se dal caso alla 2006/42/CE. / commissioning of the above mentioned until such
moment when the final machine into which they must be incorporated, has been declared compliant, the pertinent, to 2006/42/CE / die Inbetriebnahme bevor die „Endmaschine“ in die die
unvollständige Maschine eingebaut wird, als konform erklärt wurde, gegebenenfalls gemäß der Richtlinie 2006/42/EU. / la mise en service tant que la machine finale dans laquelle elle doit
être incorporée n'a pas été déclarée conforme, le cas échéant, à la norme 2006/42/CE. / la puesta en servicio hasta que la máquina final en la que será incorporada no haya sido declarada
de conformidad de acuerdo a la 2006/42/CE / a colocação em funcionamento, até que a máquina final, onde devem ser incorporadas, não for declarada em conformidade, se de acordo
com a 2006/42/CE. / Uruchomienia urządzenia do czasu, kiedy maszyna, do której ma być wbudowany, nie zostanie oceniona jako zgodna z wymogami dyrektywy 2006/42/WE, jeśli taka
procedura była konieczna. / deze in werking te stellen zolang de eindmachine waarin de niet voltooidde machine moet worden ingebouwd in overeenstemming is verklaard, indien toepasselijk
met de richtlijn 2006/42/EG.

Dosson di Casier (TV)
9 Novembre / November / November /
November / Noviembre / Novembro /
Listopad / November 2018

Amministratore Delegato / Managing Director /
General Direktor / Directeur Général / Director General /
Administrador Delegado / Dyrektor Zarządzający /
Algemeen Directeur

Andrea Menuzzo

Fascicolo tecnico a supporto / Supporting technical dossier / Unterstützung technische Dossier / soutien dossier technique / apoya expediente
técnico / apoiar dossier técnico / wspieranie dokumentacji technicznej / ondersteunende technische dossier: 801MS-0320

Came S.p.a.

Via Martiri della Libertà, 15 - 31030 Dosson di Casier - Treviso - Italy - Tel. (+39) 0422 4940 - Fax (+39) 0422 4941
info@came.it - www.came.com

Cap. Soc. 1.610.000,00 € - C.F. e P.I. 03481280265 - VAT IT 03481280265 - REA TV 275359 - Reg Imp. TV 03481280265



CAME S.P.A.

Via Martiri della Libertà, 15
31030 Dosson di Casier
Treviso - Italy
Tel. (+39) 0422 4940
Fax (+39) 0422 4941

CAME.COM

Sliding-gate operators

FA01443-EN



BKV15AGE BKV20AGE BKV25AGE
BKV15AGS BKV20AGS BKV25AGS
BKV15ALS BKV20ALS BKV25ALS
BKV15RGS BKV20RGS

INSTALLATION MANUAL

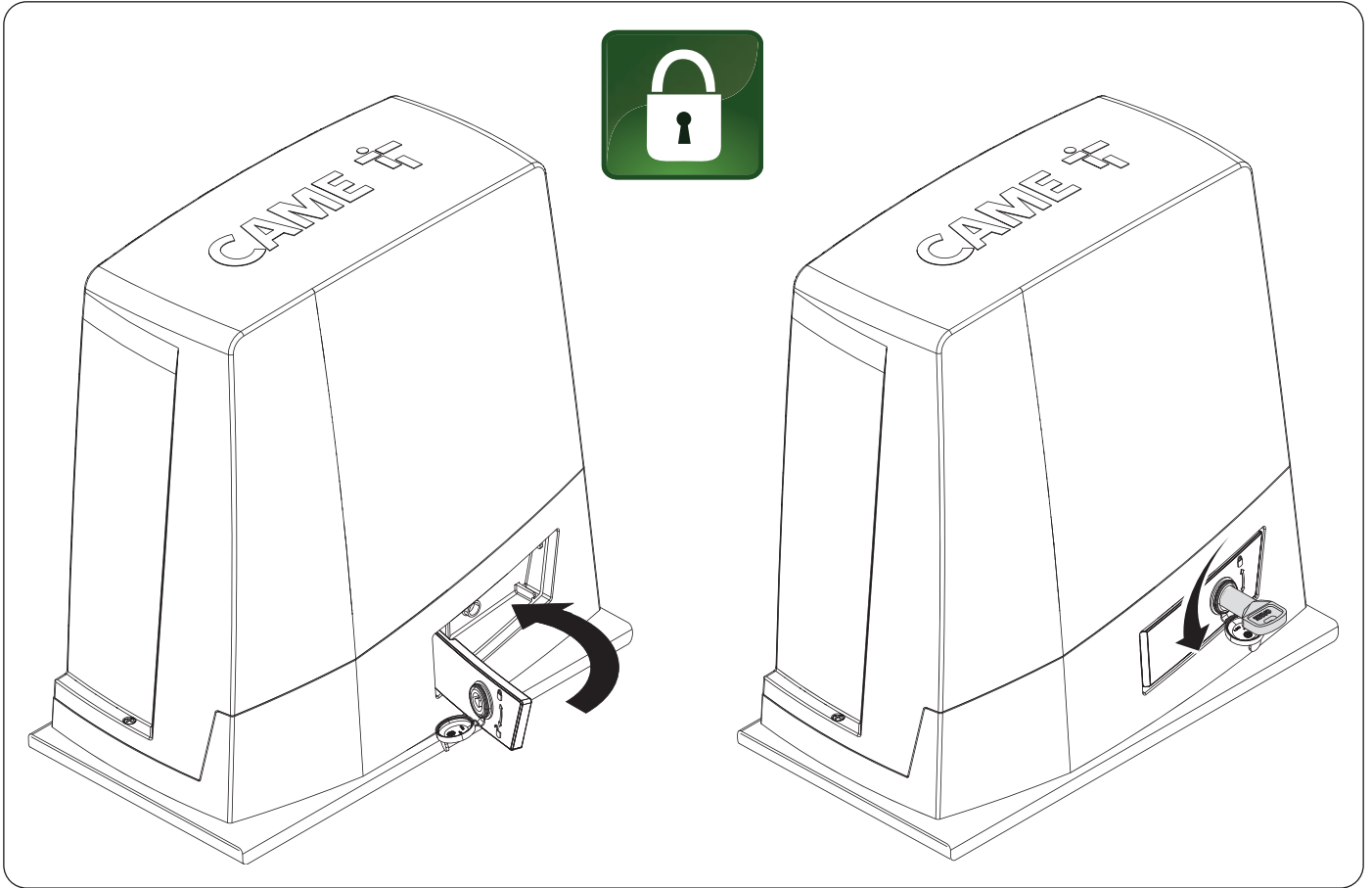
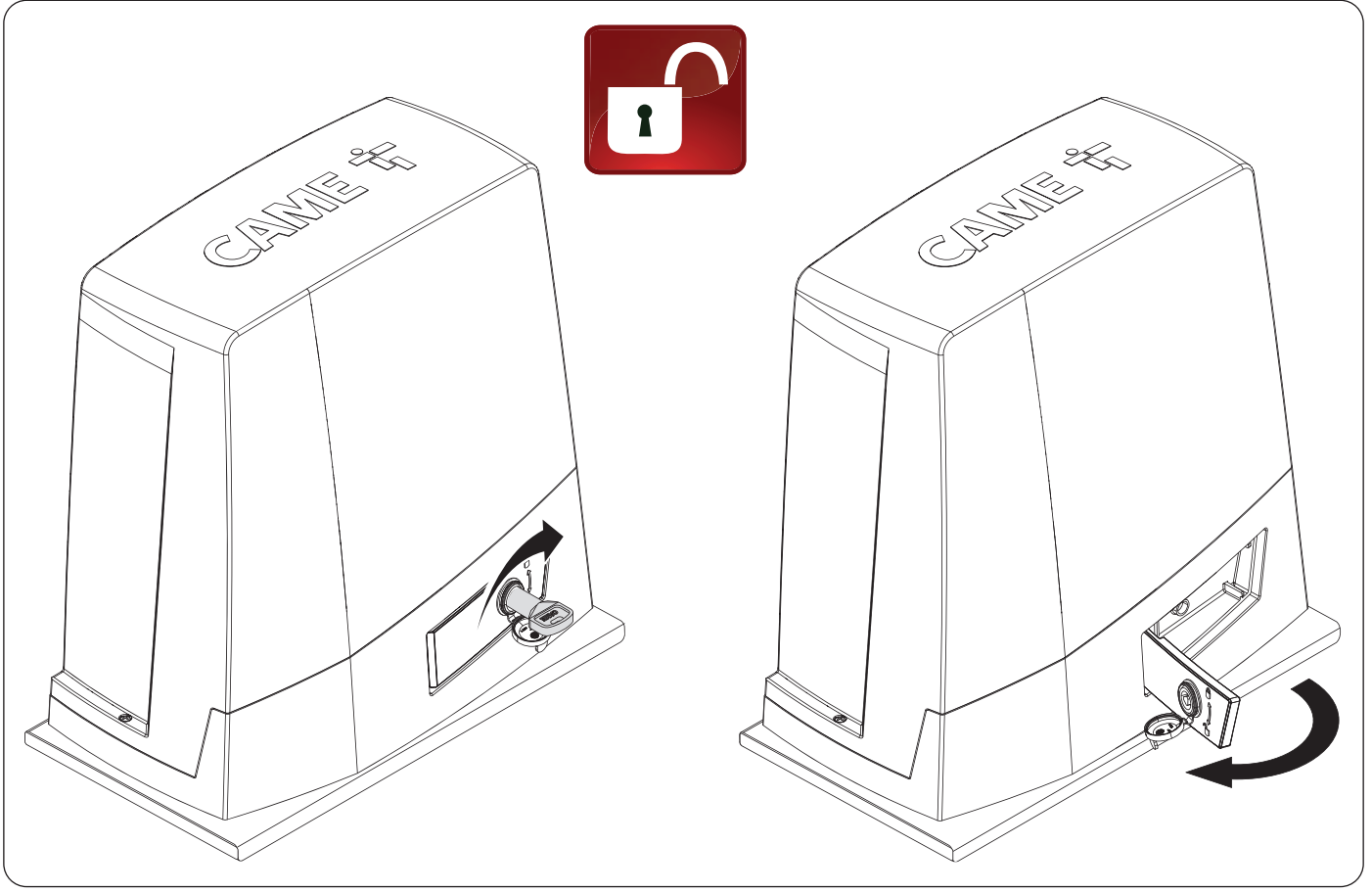

△ Important safety instructions.

△ Please follow all of these instructions. Improper installation may cause serious bodily harm.

△ Before continuing, please also read the general precautions for users.

Only use this product for its intended purpose. Any other use is hazardous. • The manufacturer cannot be held liable for any damage caused by improper, unreasonable or erroneous use. • This product is defined by the Machinery Directive (2006/42/EC) as partly completed machinery. • Partly completed machinery means an assembly which is almost machinery but which cannot in itself perform a specific application. • Partly completed machinery is only intended to be incorporated into or assembled with other machinery or other partly completed machinery or equipment thereby forming machinery to which the Machinery Directive (2006/42/EC) applies. • The final installation must comply with the Machinery Directive (2006/42/EC) and the European reference standards in force. • The manufacturer declines any liability for using non-original products, which would also void the warranty. • All operations indicated in this manual must be carried out exclusively by skilled and qualified personnel and in full compliance with the regulations in force. • The device must be installed, wired, connected and tested according to good professional practice, in compliance with the standards and laws in force. • Make sure the mains power supply is disconnected during all installation procedures. • Check that the temperature ranges given are suitable for the installation site. • Do not install on slopes i.e. any surfaces that are not perfectly level. • Do not install the operator on surfaces that could yield and bend. If necessary, add suitable reinforcements to the anchoring points. • Make sure that no direct jets of water can wet the product at the installation site (sprinklers, water cleaners, etc.). • Make sure you have set up a suitable dual-pole cut-off device along the power supply that is compliant with the installation rules. It should completely cut off the power supply according to category III surcharge conditions. • Demarcate the entire site properly to prevent unauthorised personnel from entering, especially minors. • In case of manual handling, have one person for every 20 kg that needs hoisting; for non-manual handling, use proper hoisting equipment in safe conditions. • Use suitable protection to prevent any mechanical hazards due to persons loitering within the operating range of the operator. • The electrical cables must pass through special pipes, ducts and cable glands in order to guarantee adequate protection against mechanical damage. • The electrical cables must not touch any parts that may overheat during use (such as the motor and transformer). • Before installation, check that the guided part is in good mechanical condition, and that it opens and closes correctly. • The product cannot be used to automate any guided part that includes a pedestrian gate, unless it can only be enabled when the pedestrian gate is secured. • Make sure that nobody can become trapped between the guided and fixed parts, when the guided part is set in motion. • Use additional protection to prevent your fingers from being crushed between the pinion and rack. • All fixed controls must be clearly visible after installation, in a position that allows the guided part to be directly visible, but far away from moving parts. In the case of a hold-to-run control, this must be installed at a minimum height of 1.5 m from the ground and must not be accessible to the public. • If not already present, apply a permanent tag that describes how to use the manual release mechanism close to it. • Make sure that the operator has been properly adjusted and that the safety and protection devices and the manual release are working properly. • Before handing over to the final user, check that the system complies with the harmonised standards and the essential requirements of the Machinery Directive (2006/42/EC). • Any residual risks must be indicated clearly with proper signage affixed in visible areas, and explained to end users. • Put the machine's ID plate in a visible place when the installation is complete. • If the power-supply cable is damaged, it must be immediately replaced by the manufacturer or by an authorised technical assistance centre, or in any case, by qualified staff, to prevent any risk. • Keep this manual inside the technical folder along with the manuals of all the other devices used for your automation system. • Make sure to hand over to the end user all the operating manuals of the products that make up the final machinery.

Main points of danger for people

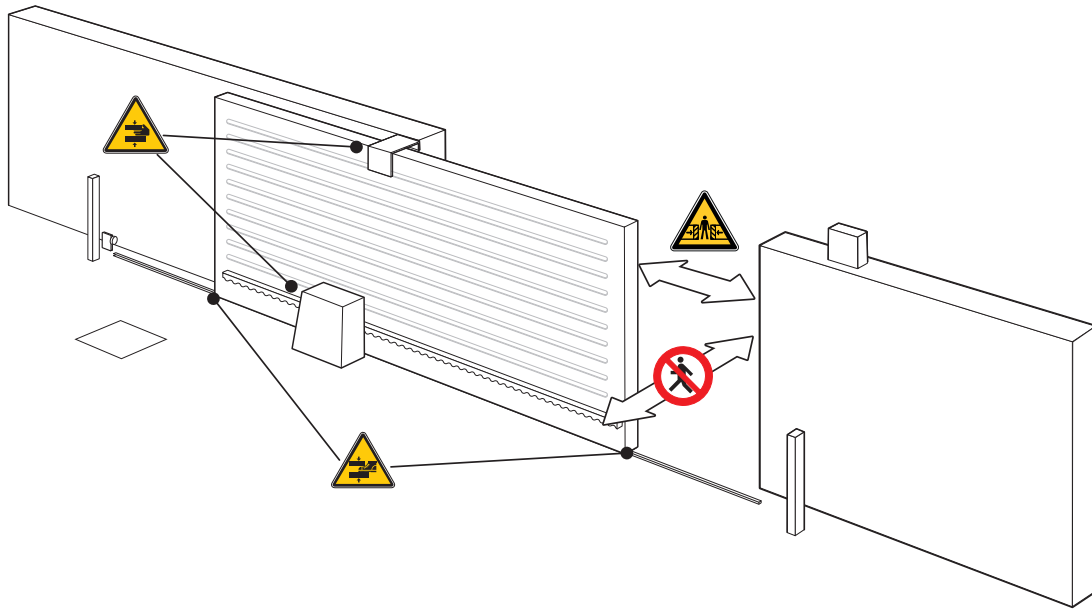

 No transiting while the barrier is moving.

 Risk of entrapment.

 Risk of trapping hands.

 Risk of trapping feet.

DISMANTLING AND DISPOSAL

 CAME S.p.A. employs an Environmental Management System at its premises. This system is certified and compliant with the UNI EN ISO 14001 standard to ensure that the environment is respected and safeguarded. Please continue safeguarding the environment. At CAME we consider it one of the fundamentals of our operating and market strategies. Simply follow these brief disposal guidelines:

DISPOSING OF THE PACKAGING

The packaging materials (cardboard, plastic, etc.) can be disposed of easily as solid urban waste, separated for recycling.

Before dismantling and disposing of the product, please always check the local laws in force.

DISPOSE OF THE PRODUCT RESPONSIBLY

DISPOSING OF THE PRODUCT

Our products are made of various materials. Most of these materials (aluminium, plastic, iron and electrical cables) are classified as solid urban waste. They can be separated for recycling and disposed of at authorised waste treatment plants.





Other components (electronic boards, transmitter batteries, etc.) may contain pollutants.

These must be removed and disposed of by an authorised waste disposal and recycling firm.

It is always advisable to check the specific laws that apply in your area.

DISPOSE OF THE PRODUCT RESPONSIBLY

Key

-  This symbol shows which parts to read carefully.
-  This symbol shows which parts describe safety issues.
-  This symbol shows what to tell users.
-  The measurements, unless otherwise stated, are in millimetres.

Description

801MS-0300

BKV15AGS - Operator with 36 V motor, featuring a control board with graphic display, Adaptive Speed & Torque Technology, 4 safety inputs, movement and obstruction-detecting device for gates weighing up to 1500 kg that are up to 20 m long.

801MS-0310

BKV20AGS - Operator with 36 V motor, featuring a control board with graphic display, Adaptive Speed & Torque Technology, 4 safety inputs, movement and obstruction-detecting device for gates weighing up to 2000 kg that are up to 20 m long.

801MS-0320

BKV25AGS - Operator with 36 V motor, featuring a control board with graphic display, Adaptive Speed & Torque Technology, 4 safety inputs, movement/obstruction-detection device and module 6 pinion for gates weighing up to 2500 kg that are up to 20 m long.

801MS-0330

BKV15RGS - High performance operator with 36V motor, featuring a control board with graphic display, Adaptive Speed & Torque Technology, 4 safety inputs, movement and obstruction-detecting device for gates weighing up to 1500 kg that are up to 20 m long.

801MS-0340

BKV20RGS - High performance operator with 36V motor, featuring a control board with graphic display, Adaptive Speed & Torque Technology, 4 safety inputs, movement and obstruction-detecting device for gates weighing up to 2000 kg that are up to 20 m long.

801MS-0350

BKV15AGE - Plus operator with 36 V motor, featuring a control board with graphic display, Adaptive Speed & Torque Technology, 4 safety inputs, magnetic limit switches and clock accessory included for gates weighing up to 1500 kg that are up to 20 m long.

801MS-0360

BKV20AGE - Plus operator with 36 V motor, featuring a control board with graphic display, Adaptive Speed & Torque Technology, 4 safety inputs, magnetic limit switches and clock accessory included for gates weighing up to 2000 kg that are up to 20 m long.

801MS-0370

BKV25AGE - Plus operator with 36 V motor, featuring a control board with graphic display, Adaptive Speed & Torque Technology, 4 safety inputs, module 6 pinion, magnetic limit switches and clock accessory included for gates weighing up to 2500 kg that are up to 20 m long.

801MS-0301

BKV15ALS - High-performance operator with 36V motor, featuring a control board with graphic display, Adaptive Speed & Torque Technology, 4 safety inputs, movement and obstruction-detecting device for gates weighing up to 1500 kg that are up to 20 m long. RAL 7040 grey cover.

801MS-0311

BKV20ALS - High-performance operator with 36V motor, featuring a control board with graphic display, Adaptive Speed & Torque Technology, 4 safety inputs, movement and obstruction-detecting device for gates weighing up to 2000 kg that are up to 20 m long. RAL 7040 grey cover.

801MS-0321

BKV25ALS - High-performance operator with 36 V motor, featuring a control board with graphic display, Adaptive Speed & Torque Technology, 4 safety inputs, movement and obstruction-detecting device, and module 6 pinion for gates weighing up to 2500 kg that are up to 20 m long. RAL 7040 grey cover.

Intended use

Solution for large sliding gates.

-  Any installation and/or use other than that specified in this manual is forbidden.

Description of parts

Operator

- ❶ Cover
- ❷ Board protection cover
- ❸ Control board
- ❹ Board-holder support
- ❺ Gearmotor
- ❻ Mechanical limit switch
- ❼ Anchoring plate
- ❽ Housing for two emergency batteries
- ❾ Housing for thermostat with cartridge
- ❿ Housing for the RGSM001 module
- ⓫ Housing for the LBB card
- ⓬ Housing for the RGP1 module
- ⓭ Release lever
- ⓮ Mechanical limit-switch tabs
- ⓯ Fixtures and fittings
- ⓰ Housing for UR042 module
- ⓱ Holes for the electrical cables
- ⓲ Housing for SMA module
- ⓳ Magnetic limit switch*
- ⓴ Magnetic limit-switch tabs*
- ⓵ Clock card (806SA-0120)*

* Only for BKV15AGE, BKV20AGE and BKV25AGE

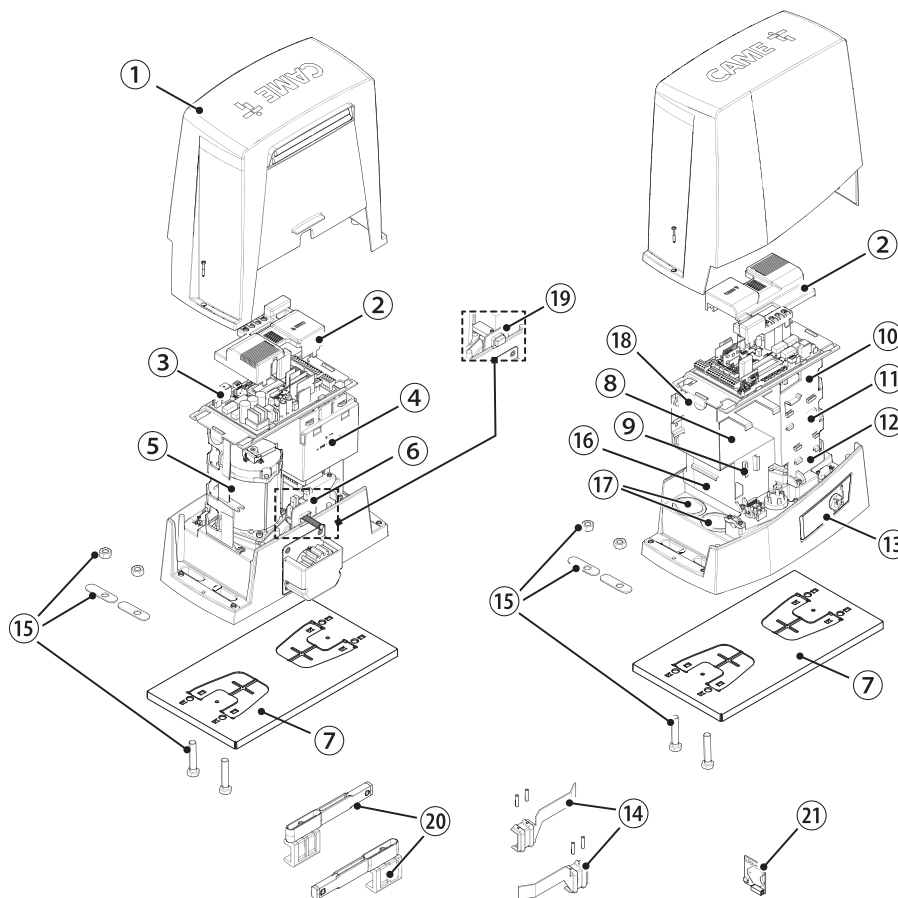

Control board

The functions on the input and output contacts, the time settings and user management are set and viewed on the display.

All connections are protected by quick fuses.

For the system to work properly, before fitting any plug-in card, DISCONNECT THE MAIN POWER SUPPLY and remove any batteries.

Before working on the control panel, disconnect the mains power supply and remove the batteries, if any.

- | | |
|---|---|
| <ul style="list-style-type: none"> ❶ Terminal board for connecting the gearmotor ❷ Terminal board for connecting the encoder ❸ Terminal board for connecting the RGP1 module or LBB card ❹ Programming buttons ❺ RSE card connector ❻ Connector for CAME KEY ❼ Connector for plug-in radio frequency card (AF) ❽ Terminal board for connecting the antenna ❾ Terminal board for connecting the safety devices ❿ Terminal board for connecting the paired function or the CRP ⓫ Terminal board for connecting control devices ⓬ Terminal board for connecting the keypad selector ⓭ Terminal board for connecting the transponder selector switch | <ul style="list-style-type: none"> ⓮ Terminal board for connecting the signalling devices ⓯ Terminal board for B1-B2 output ⓰ Connector for the R700 or R800 decoding card ⓱ Connector for the RIOCN8WS module ⓲ Connector for the clock card (806SA-0120) ⓳ Terminal board for limit-switch micro-switches ⓴ Accessories fuse ⓵ Control board fuse ⓶ Terminal board for connecting the transformer ⓷ Memory Roll card connector ⓸ Display ⓹ Line fuse ⓺ Power supply terminal board |
|---|---|

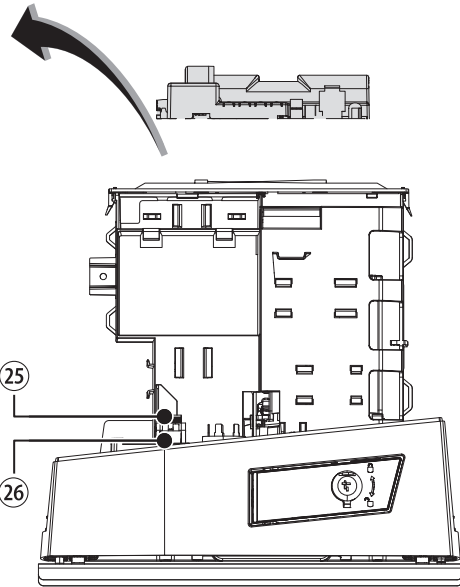
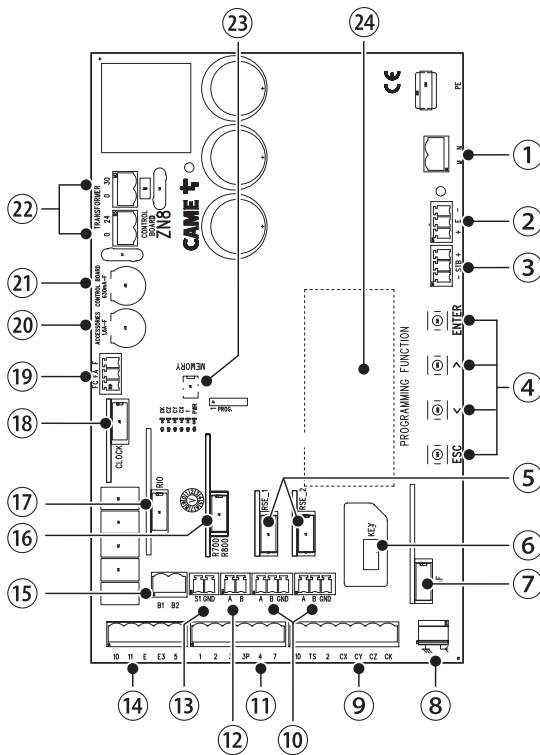

Remove the card cover before inserting the cards into the connectors.

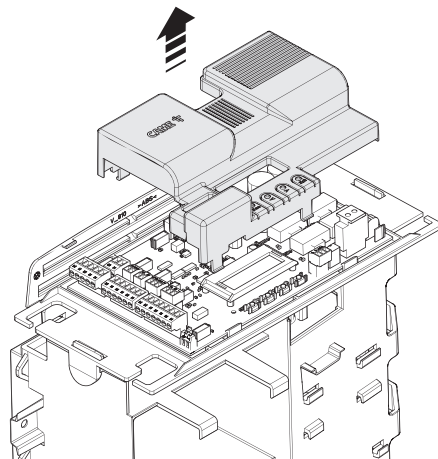
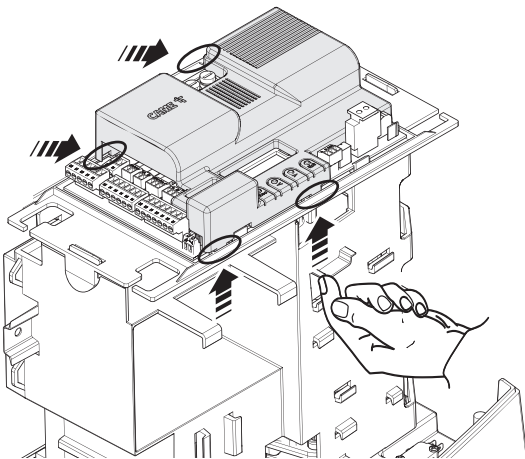

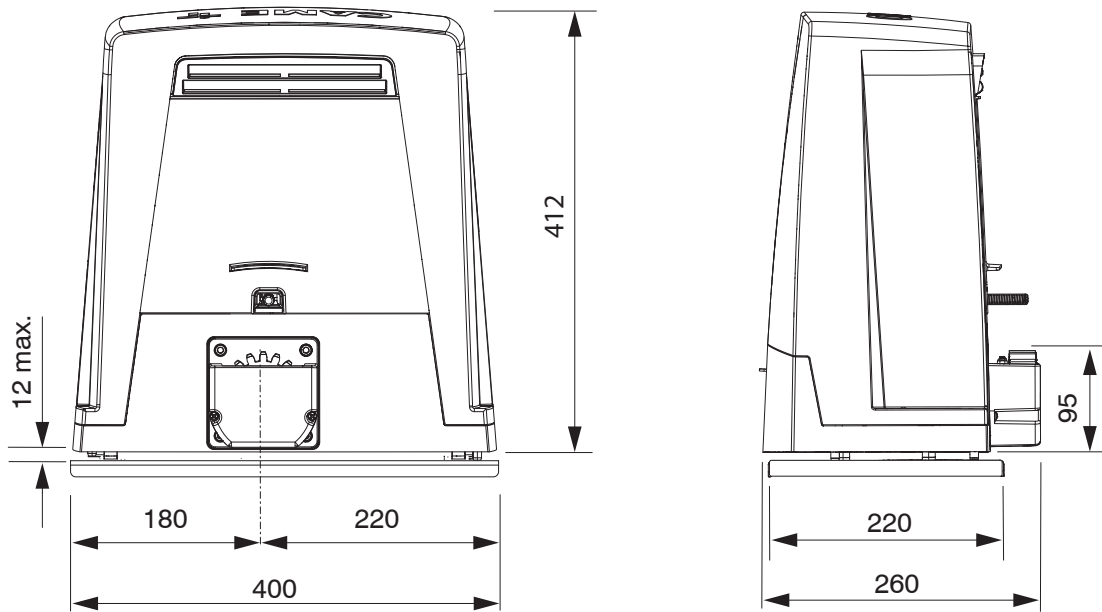

Usage limitations

MODELS	BKV15AGS	BKV20AGS	BKV25AGS	BKV15RGS	BKV20RGS
Pinion module	4	4	6	4	4
Maximum gate-leaf length (m)	20	20	20	20	20
Maximum gate-leaf weight (kg)	1500	2000	2500	1500	2000

MODELS	BKV15AGE	BKV20AGE	BKV25AGE	BKV15ALS	BKV20ALS	BKV25ALS
Pinion module	4	4	6	4	4	6
Maximum gate-leaf length (m)	20	20	20	20	20	20
Maximum gate-leaf weight (kg)	1500	2000	2500	1500	2000	2500

Technical data

MODELS	BKV15AGS	BKV20AGS	BKV25AGS	BKV15RGS	BKV20RGS
Power supply (V - 50/60 Hz)	230 AC	230 AC	230 AC	120 AC	120 AC
Motor power supply (V)	36 DC	36 DC	36 DC	36 DC	36 DC
Board power supply (V)	26 DC	26 DC	26 DC	26 DC	26 DC
Standby consumption (W)	14	14	14	14	14
Standby consumption with the RGP1 (W) module	0,8	0,8	0,8	0,8	0,8
Power (W)	200	250	300	200	250
Transformer thermal protection (°C)	120	120	120	120	120
Current draw (mA)	8	9	10	8	9
Maximum current draw (mA)	20	20	20	20	20
Colour	RAL 7024	RAL 7024	RAL 7024	RAL 7024	RAL 7024
Operating temperature (°C)	-20 ÷ +55	-20 ÷ +55	-20 ÷ +55	-20 ÷ +55	-20 ÷ +55
Thrust (N)	800	900	1000	800	900
Maximum thrust (N)	1200	1350	1500	1200	1350
Maximum operating speed (m/min)	12	12	12	12	12
Operating time (s)	180	180	180	180	180
Cycles/hour	CONTINUOUS OPERATION	CONTINUOUS OPERATION	CONTINUOUS OPERATION	CONTINUOUS OPERATION	CONTINUOUS OPERATION
Protection rating (IP)	54	54	54	54	54
Insulation class	I	I	I	I	I
Reduction ratio (i)	40	40	40	40	40
Weight (kg)	20	21	21	20	21

MODELS	BKV15AGE	BKV20AGE	BKV25AGE	BKV15ALS	BKV20ALS	BKV25ALS
Power supply (V - 50/60 Hz)	230 AC	230 AC	230 AC	230 AC	230 AC	230 AC
Motor power supply (V)	36 DC	36 DC	36 DC	36 DC	36 DC	36 DC
Board power supply (V)	26 DC	26 DC	26 DC	26 DC	26 DC	26 DC
Standby consumption (W)	14	14	14	14	14	14
Standby consumption with the RGP1 (W) module	0,8	0,8	0,8	0,8	0,8	0,8
Power (W)	200	250	300	200	250	300
Transformer thermal protection (°C)	120	120	120	120	120	120
Current draw (mA)	8	9	10	8	9	10
Maximum current draw (mA)	20	20	20	20	20	20
Colour	RAL 7024	RAL 7024	RAL 7024	RAL 7040	RAL 7040	RAL 7040
Operating temperature (°C)	-20 ÷ +55	-20 ÷ +55	-20 ÷ +55	-20 ÷ +55	-20 ÷ +55	-20 ÷ +55
Thrust (N)	800	900	1000	800	900	1000
Maximum thrust (N)	1200	1350	1500	1200	1350	1500
Maximum operating speed (m/min)	12	12	12	12	12	12
Operating time (s)	180	180	180	180	180	180
Cycles/hour	CONTINUOUS OPERATION	CONTINUOUS OPERATION	CONTINUOUS OPERATION	CONTINUOUS OPERATION	CONTINUOUS OPERATION	CONTINUOUS OPERATION
Protection rating (IP)	54	54	54	54	54	54
Insulation class	I	I	I	I	I	I
Reduction ratio (i)	40	40	40	40	40	40
Weight (kg)	20	21	21	20	21	21

Fuse table

MODELS	BKV15AGS	BKV20AGS	BKV25AGS	BKV15RGS	BKV20RGS
Line fuse	2 A F	2 A F	2 A F	4 A F	4 A F
Control-board fuse	630 mA F	630 mA F	630 mA F	630 mA F	630 mA F
Accessories fuse	1.6 A F	1.6 A F	1.6 A F	1.6 A F	1.6 A F

MODELS	BKV15AGE	BKV20AGE	BKV25AGE	BKV15ALS	BKV20ALS	BKV25ALS
Line fuse	2 A F	2 A F	2 A F	2 A F	2 A F	2 A F
Control-board fuse	630 mA F	630 mA F	630 mA F	630 mA F	630 mA F	630 mA F
Accessories fuse	1.6 A F	1.6 A F	1.6 A F	1.6 A F	1.6 A F	1.6 A F

Cable types and minimum thicknesses

Cable length (m)	up to 20	from 20 to 30
Power supply 230 V AC	3G x 1.5 mm ²	3G x 2.5 mm ²
24 V AC/DC flashing beacon	2 x 1 mm ²	2 x 1 mm ²
TX Photocells	2 x 0.5 mm ²	2 x 0.5 mm ²
RX photocells	4 x 0.5 mm ²	4 x 0.5 mm ²
Command and control devices	* no. x 0.5 mm ²	* no. x 0.5 mm ²

* no. = see product assembly instructions - Warning: the cable cross-section is indicative and varies according to the motor power and cable length.

 When operating at 230 V and outdoors, use H05RN-F cables compliant with 60245 IEC 57 (IEC); when operating indoors, use H05VV-F cables compliant with 60227 IEC 53 (IEC). For power supplies up to 48 V, you can use FROR 20-22 II cables compliant with EN 50267-2-1 (CEI).

 To connect the antenna, use RG58 cable (up to 5 m).

 For paired connection and CRP, use UTP CAT5 cable (up to 1,000 m).

 If the cable lengths differ from those specified in the table, define the cable cross-sections according to the actual power draw of the connected devices and in line with regulation CEI EN 60204-1.

 For multiple, sequential loads along the same line, recalculate the values in the table according to the actual power draw and distances. For information on connecting products not covered in this manual, please see the documentation accompanying the products themselves.

INSTALLATION

 The following illustrations are examples only. The space available for fitting the operator and accessories varies depending on the area where it is installed. It is up to the installer to find the most suitable solution.

 The drawings show an operator fitted on the left.

Preliminary operations

Dig a hole for the foundation frame.

Set up the corrugated tubes needed for the wiring coming out of the junction pit.

 Use $\varnothing 40$ mm corrugated tubes to connect the gearmotor to the accessories.

 The number of tubes depends on the type of system and the accessories that are going to be fitted.

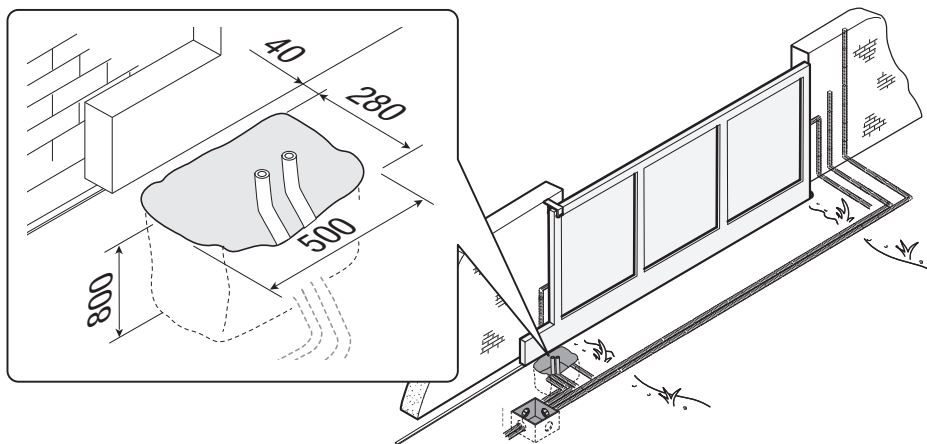

Laying the anchoring plate

Set up a foundation frame that is larger than the anchoring plate.

Insert the foundation frame into the dug hole.

 The foundation frame must protrude by 50 mm, above ground level.

Fit an iron cage in the foundation frame to reinforce the concrete.

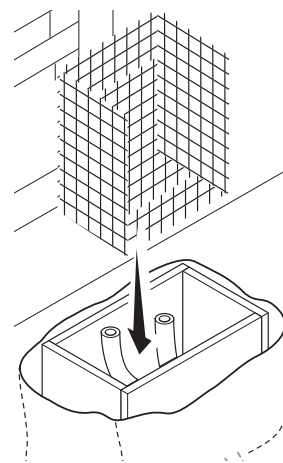
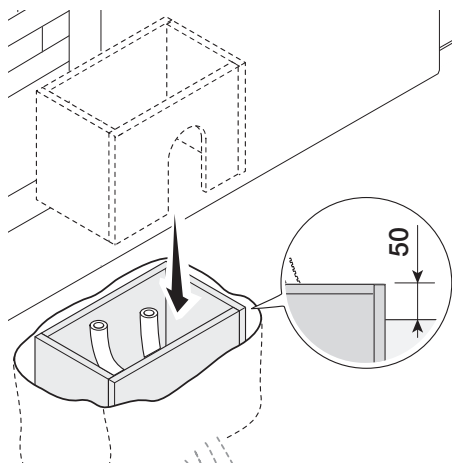

Insert the screws supplied in the anchoring plate.
 Lock the screws in place with the nuts supplied.
 Remove the pre-shaped clamps using a screwdriver.
 Fit the anchoring plate in the iron cage.

 The tubes must pass through the existing holes.

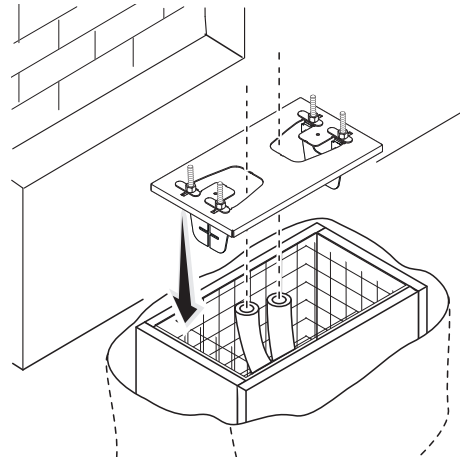
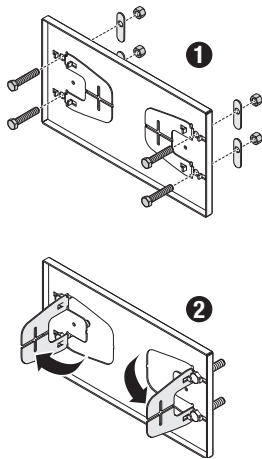

Position the anchoring plate, taking note of the measurements shown in the drawing.

 If the gate does not have a rack, proceed with the installation.

 See the section "FASTENING THE RACK".

Cast cement into the foundation frame.

 The plate must be perfectly level and the screw threads completely above surface.
 Wait at least 24 hours for the cement to dry.

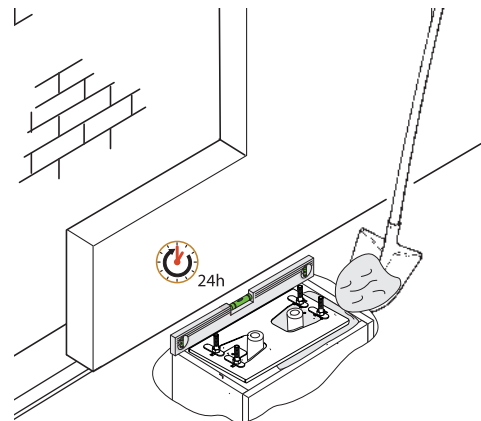
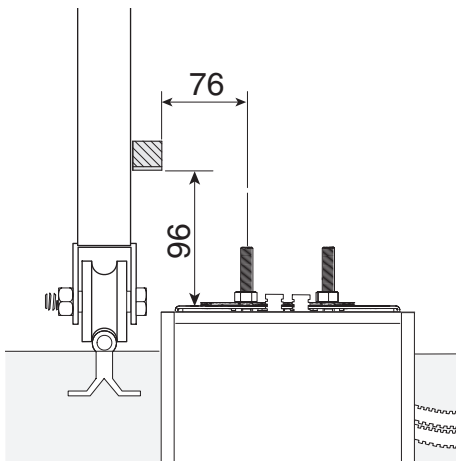

Remove the foundation frame.
 Fill the hole with soil around the concrete block.

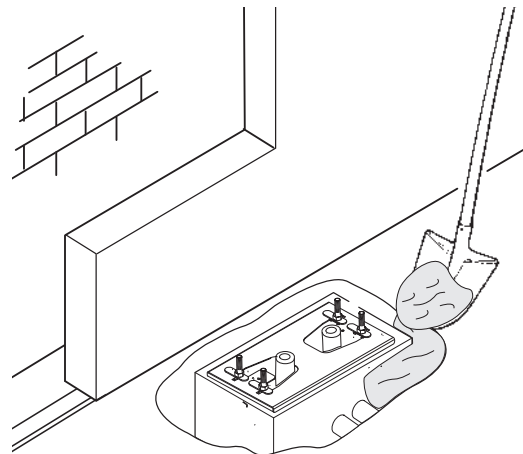
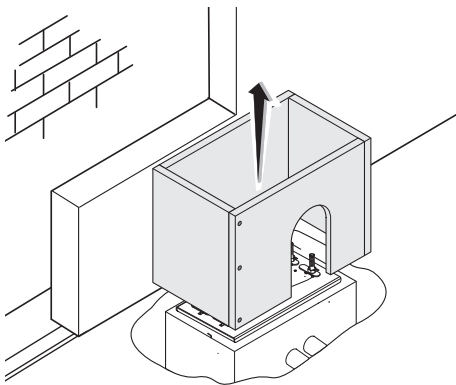

Remove the nuts from the screws.
Insert the electrical cables into the tubes until they protrude by about 600 mm.

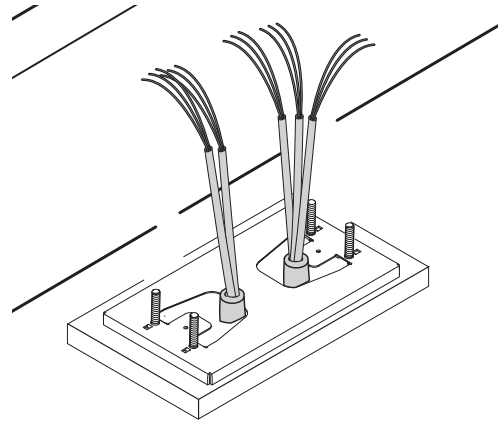
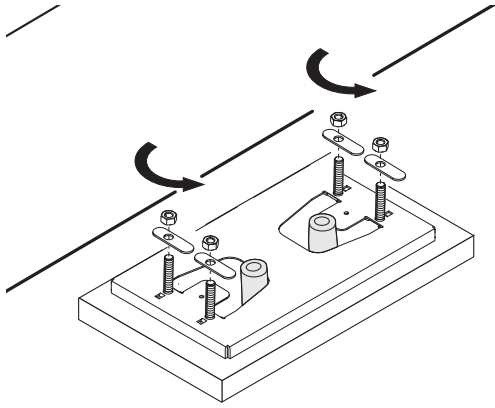

Setting up the operator

Remove the operator cover.
Place the operator on top of the anchoring plate.

 The electrical cables must pass under the operator foundation frame

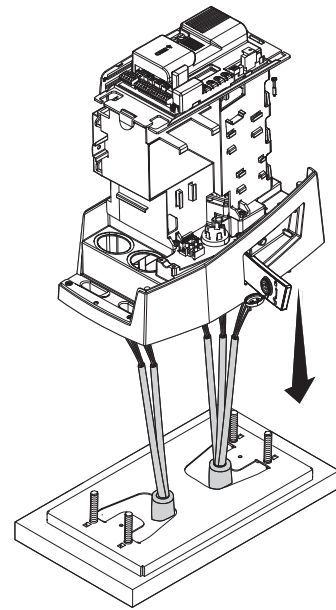
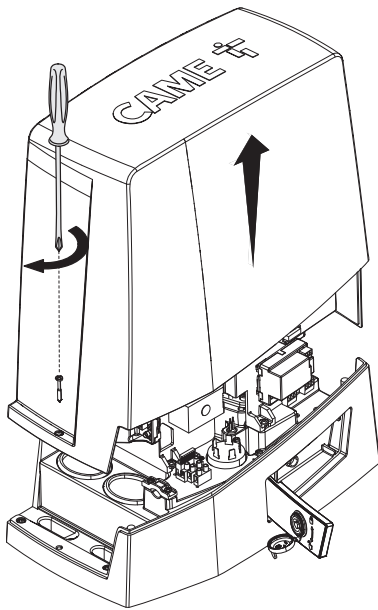

Make a hole in the cable gland.

Thread the cables through the cable gland.

Lift the operator by 5-10 mm from the plate by adjusting the threaded feet, to allow for any adjustments that may need to be made between the rack and pinion.

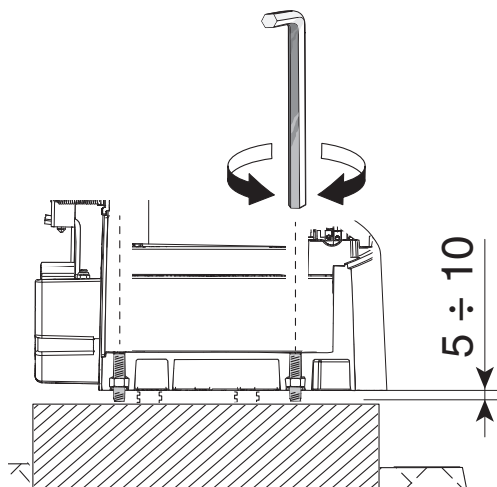
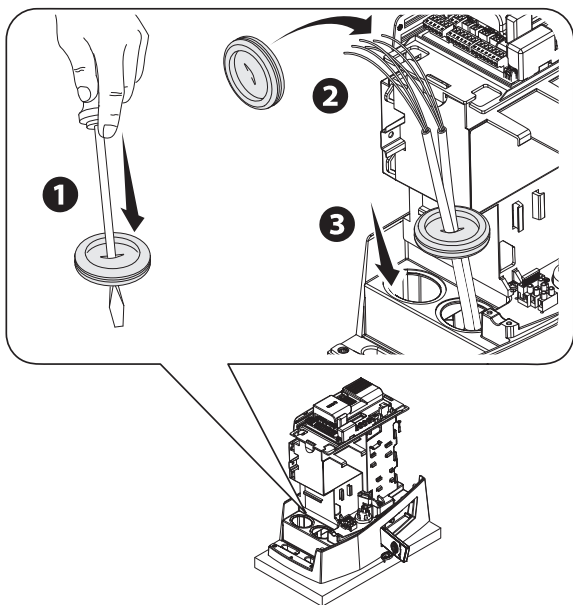

Fastening the rack

1 Release the operator.

2 Rest the rack on the pinion.

3 Weld or fasten the rack to the gate along its entire length.

 To assemble the rack modules, use an extra piece and rest it under the joint, then fasten it in place using two clamps.

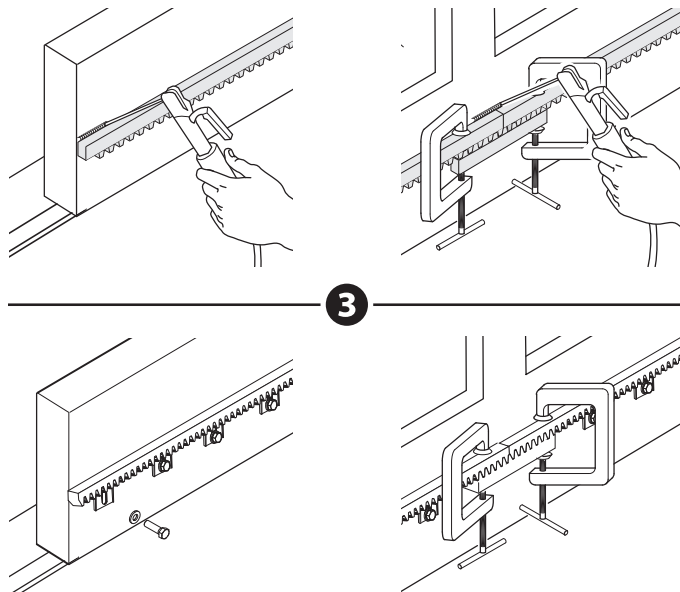
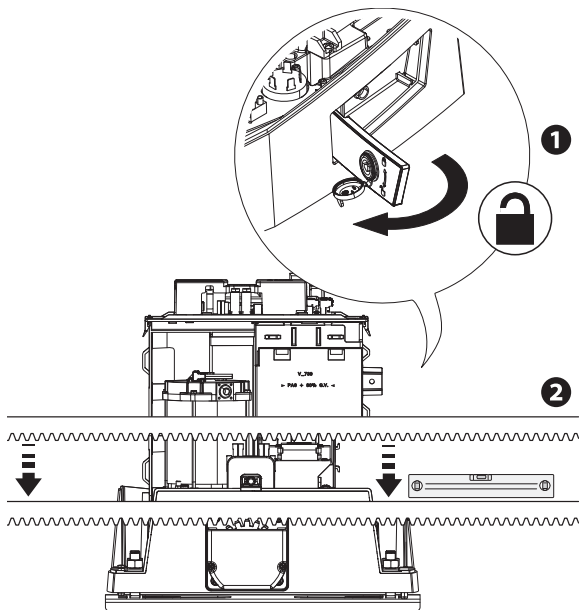

Adjusting the pinion-rack coupling

Open and close the gate manually.

Adjust the pinion-rack coupling distance using the threaded feet (vertical adjustment) and the holes (horizontal adjustment).

 The weight of the gate must not bear down upon the operator.

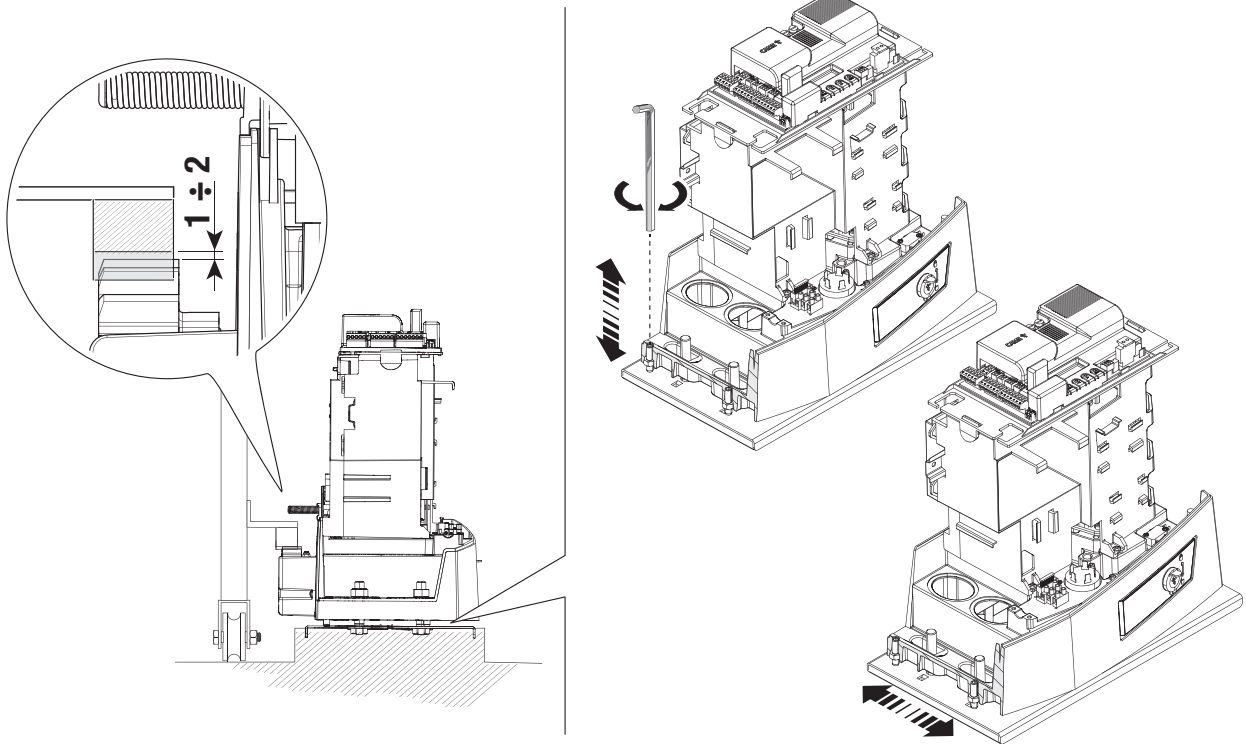

Fastening the operator in place

 Only fasten the operator after adjusting the pinion-rack coupling.

Fasten the operator to the anchoring plate using stoppers and nuts.

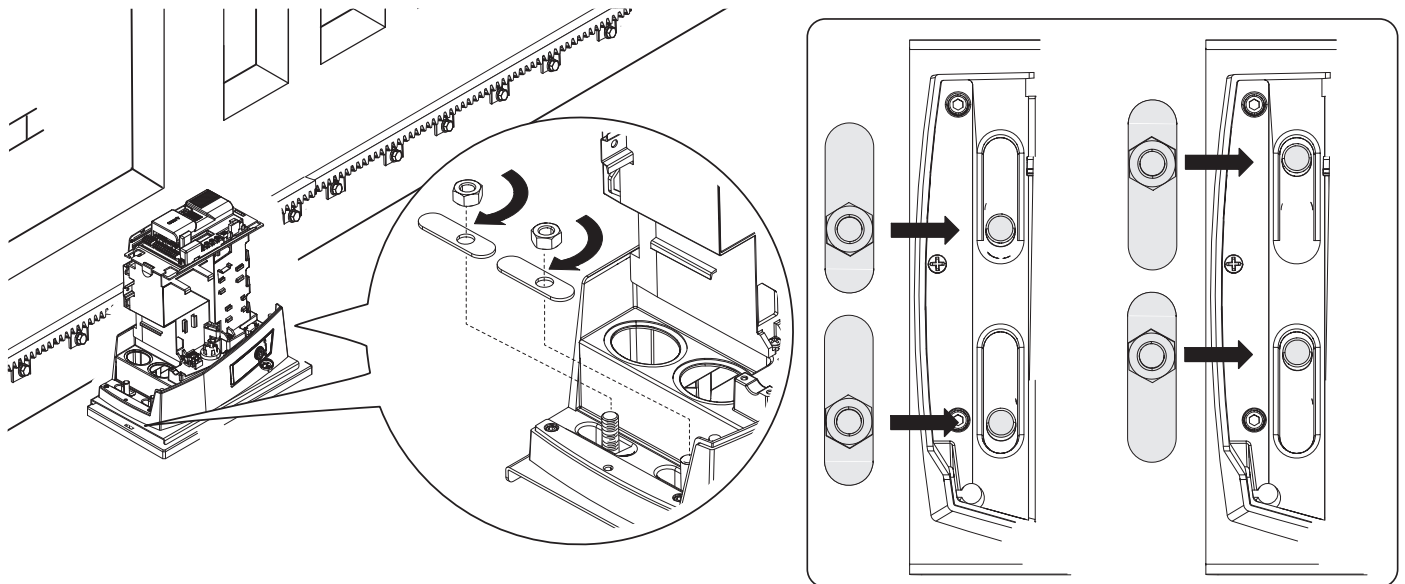

Determining the travel end points with mechanical limit switches

- 1 Open the gate.
- 2 Insert the opening limit-switch tab in the rack.
The spring must trigger the microswitch.
- 3 Fasten the opening limit-switch tab using the grub screws supplied.

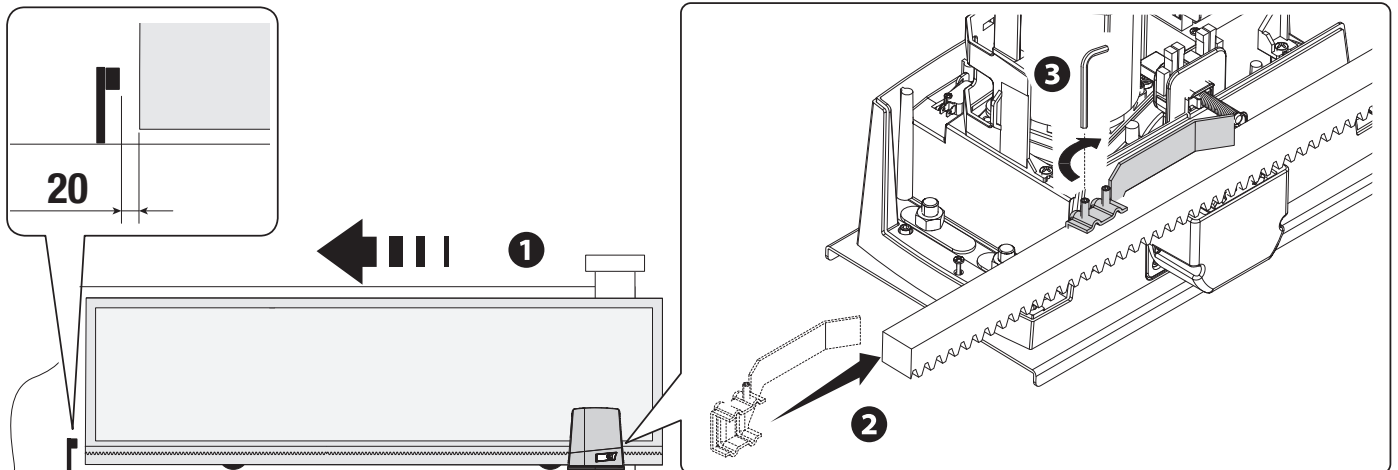

- 4 Close the gate.
- 5 Insert the closing limit-switch tab in the rack.
The spring must trigger the microswitch.
- 6 Fasten the closing limit-switch tab using the grub screws supplied.

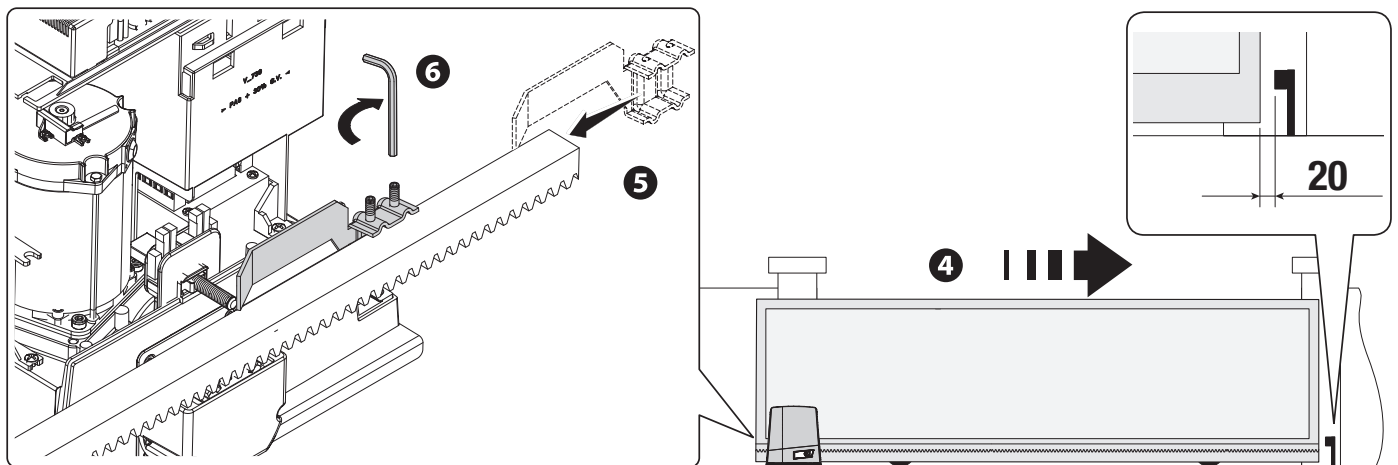

Establishing the limit-switch points with magnetic limit switches

* Only for BKV15AGE, BKV20AGE and BKV25AGE

- A** Magnetic limit-switch tabs during closing
- B** Magnetic limit-switch tabs during opening

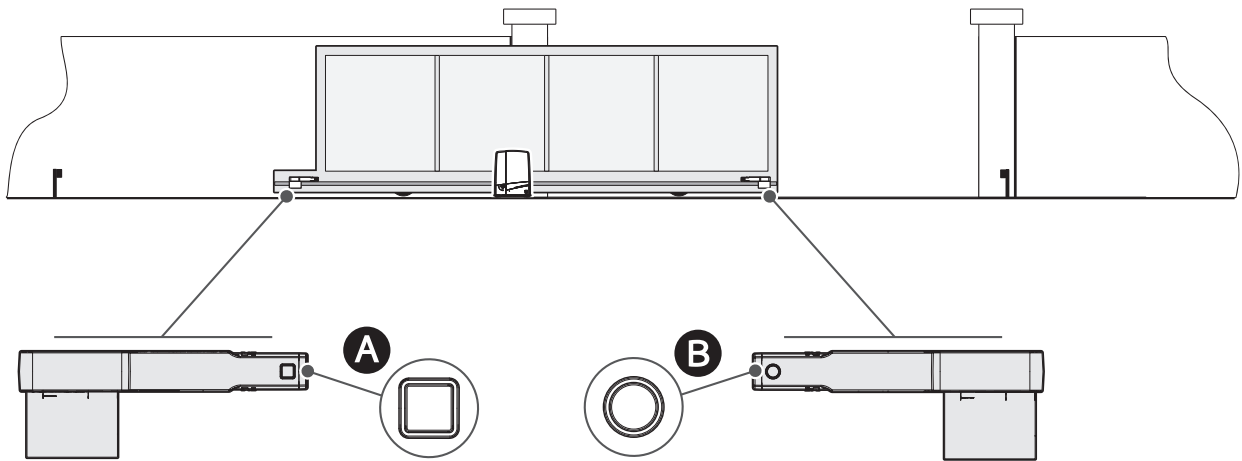

Open the gate.

Insert the magnetic opening limit-switch tab on the rack.

The tab magnet must be between 10 and 30 mm from the magnetic sensor.

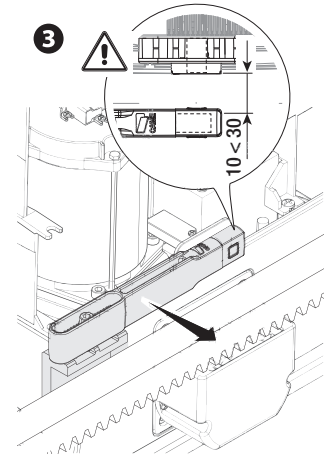
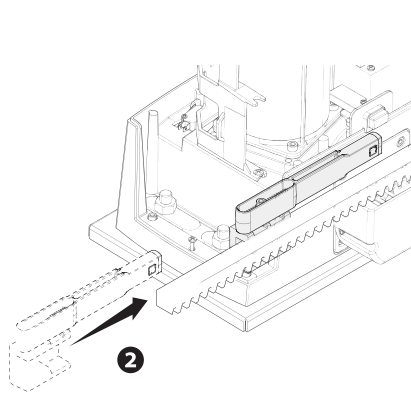
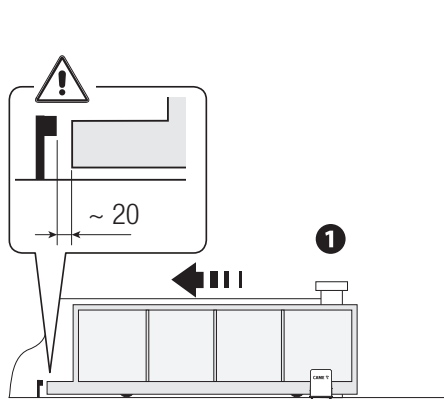

Fasten the support to the rack using the grub screws supplied.

The limit-switch tab magnet must be perpendicular to the magnetic sensor.

Fasten the limit-switch tab using the screw (supplied).

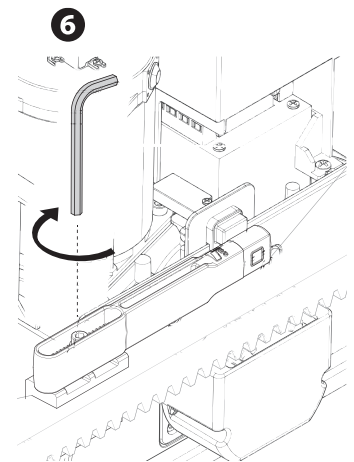
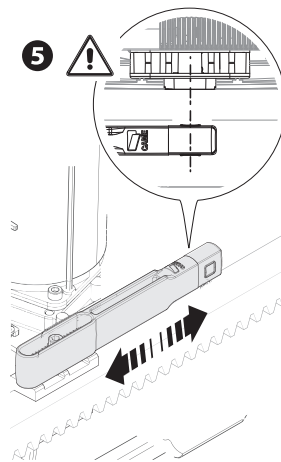
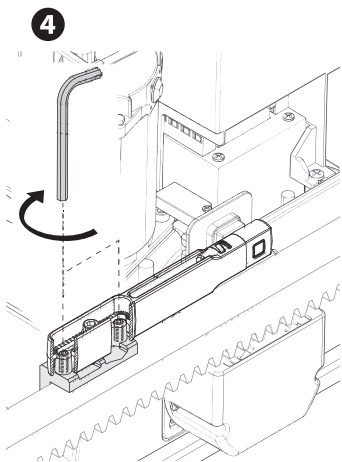

Close the gate.

Insert the magnetic closing limit-switch tab on the rack.

 The tab magnet must be between 10 and 30 mm from the magnetic sensor.

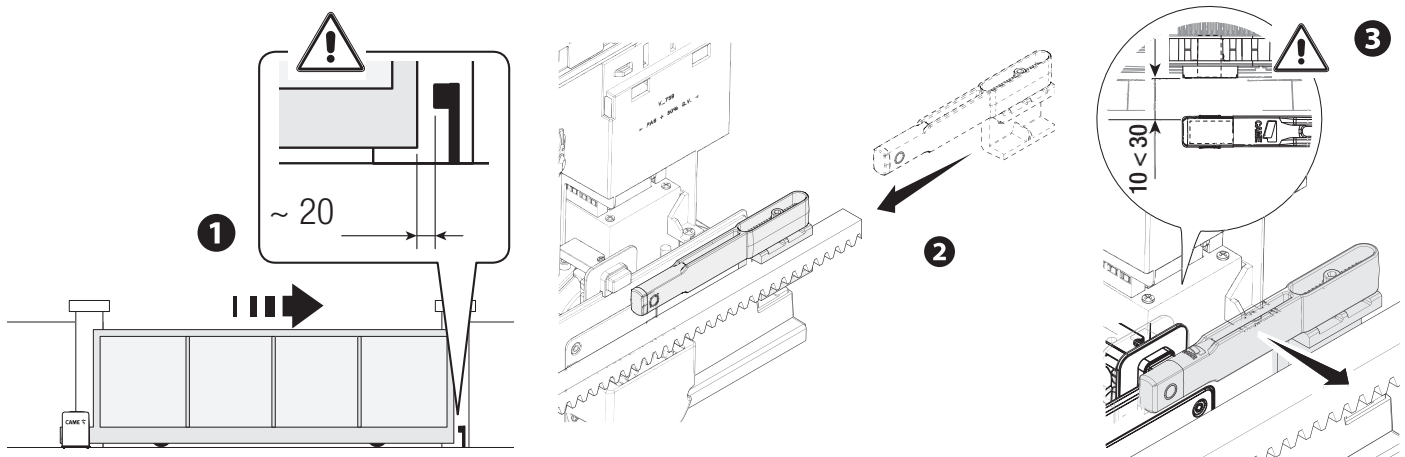

Fasten the support to the rack using the grub screws supplied.

 The limit-switch tab magnet must be perpendicular to the magnetic sensor.

Fasten the limit-switch tab using the screw (supplied).

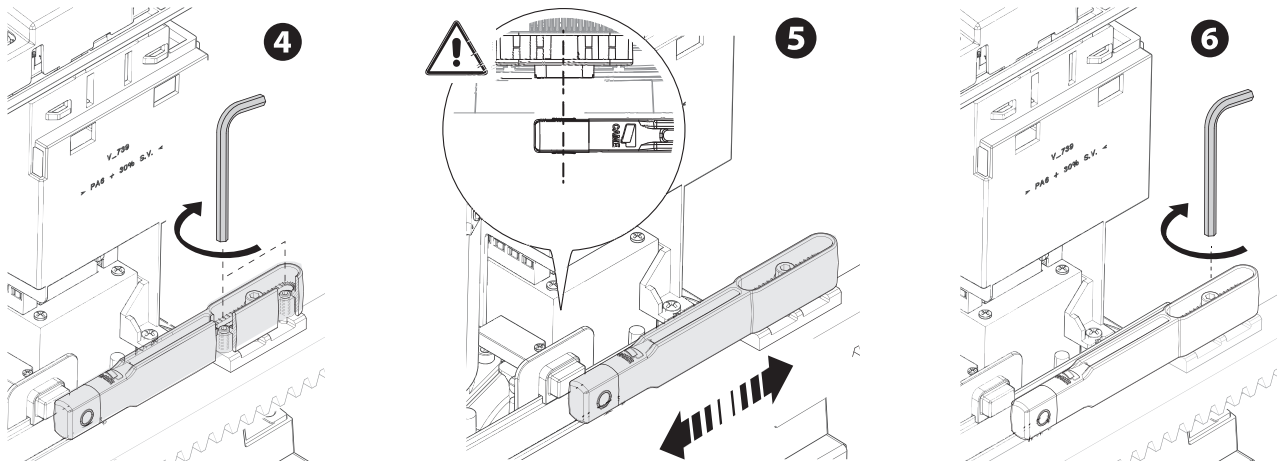

Passing the electrical cables

- Connect all wires and cables in compliance with the law. The electrical cables must not touch any parts that may overheat during use (such as the motor and transformer).
- Use cable glands to connect the devices to the control panel. One of these must be used exclusively for the power supply cable.

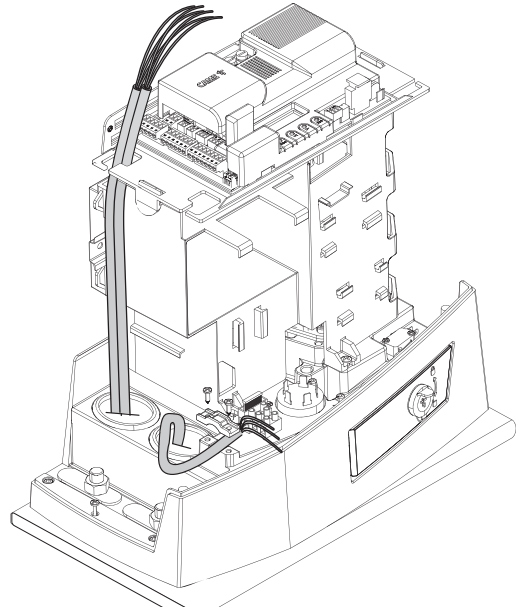
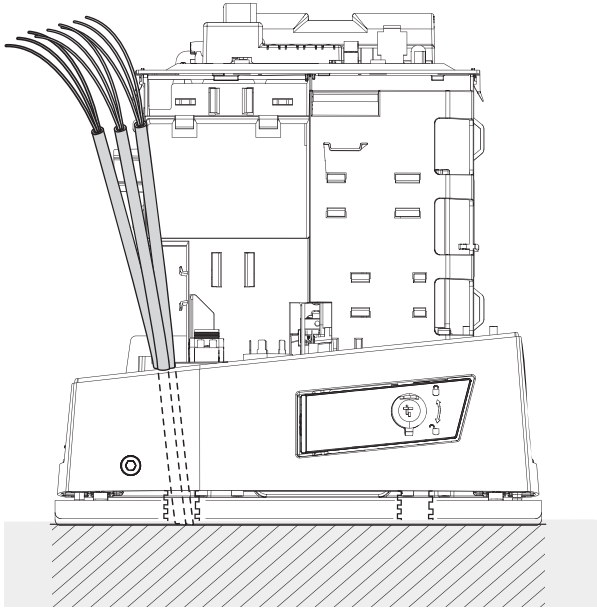

Power supply

Make sure the mains power supply is disconnected during all installation procedures.

⚠ Before working on the control panel, disconnect the mains power supply and remove the batteries, if any.

Connecting to the mains (120/230 V AC - 50/60 Hz)

- L Phase
- N Neutral
- ⊕ Earth

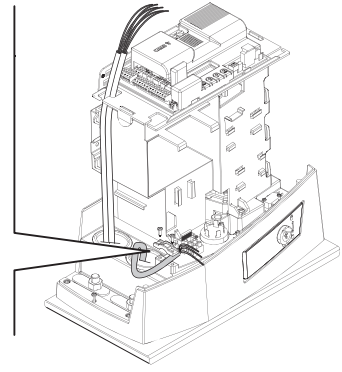
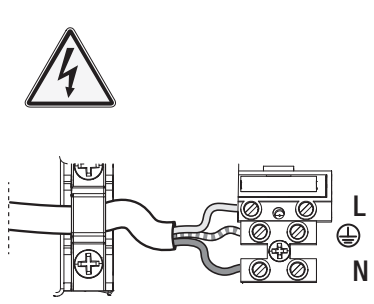

Power supply output for accessories

The output normally delivers 24 V AC.

The sum of the power draw for the connected accessories must not exceed 20 W.

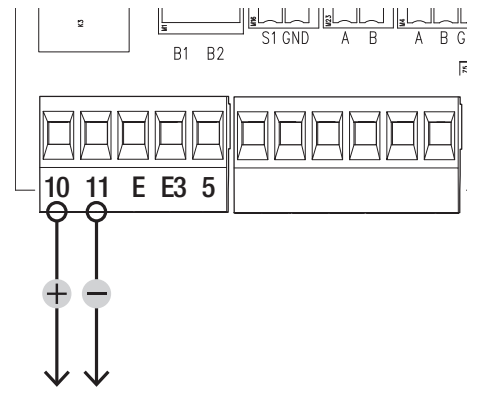

Maximum capacity of contacts

Device	Output	Power supply (V)	Power (W)
Accessories	10 - 11	24 AC/DC	20
Additional light	10 - E3	24 AC/DC	12
Flashing beacon	10 - E	24 AC/DC	3
Operator status warning light	10 - 5	24 AC/DC	3

Remove the protective cover on the control board.

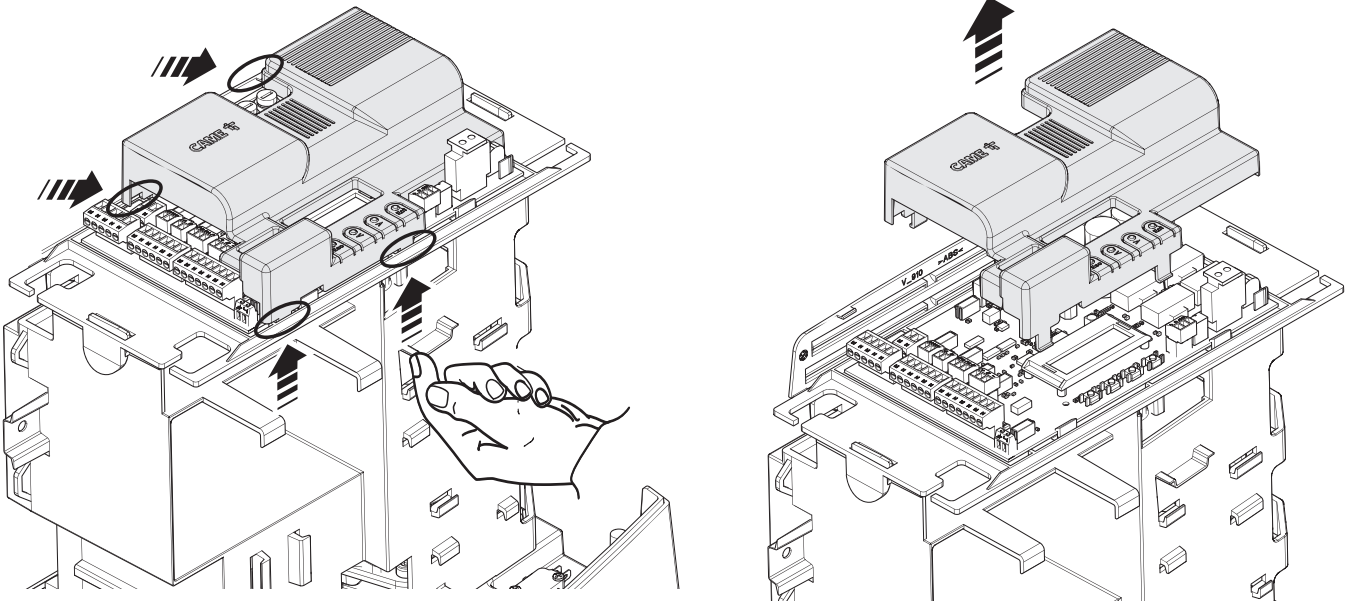

Signalling devices

1 Flashing beacon

It flashes when the operator opens and closes.

2 Additional light

It increases the light in the manoeuvring area.

3 Operator status warning light

It notifies the user of the operator status.

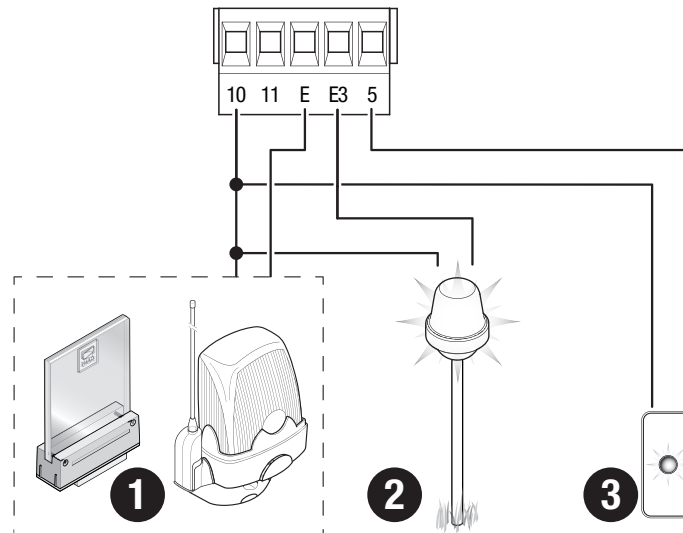

Command and control devices

- 1 Card reader
- 2 Transponder selector switch
- 3 Keypad selector
- 4 STOP button (NC contact)

Stop the gate and exclude automatic closing. Use a control device to resume movement.

 If the contact is not used, it must be deactivated during programming.

- 5 Control device (NO contact)

OPEN ONLY function

- 6 Control device (NO contact)

PARTIAL OPENING function

- 7 Control device (NO contact)

CLOSE ONLY function

- 8 Control device (NO contact)

OPEN-CLOSE (step-by-step) or OPEN-STOP-CLOSE-STOP (sequential) function

- 9 Antenna with RG58 cable

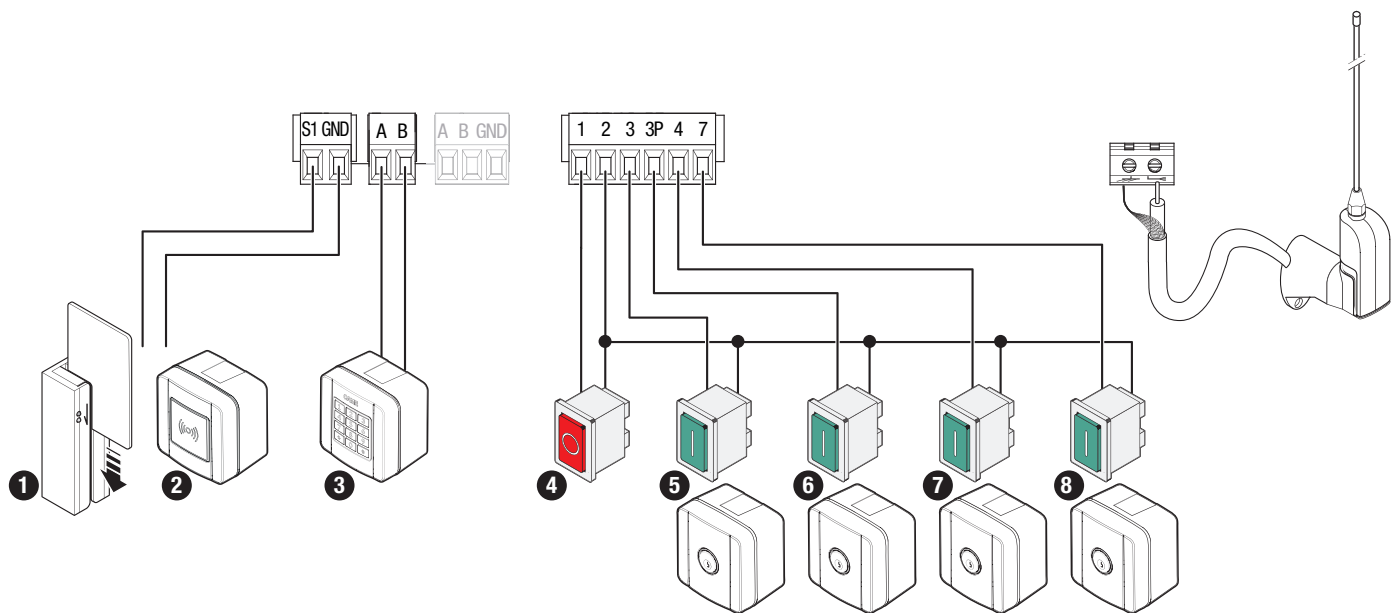

Safety devices

Connect the safety devices to the CX, CY CZ and/or CK inputs (NC contacts).

During programming, configure the type of action that must be performed by the device connected to the input.

 If contacts CX, CY, CZ and/or CK are not used, they must be deactivated during programming.

DELTA photocells

Standard connection

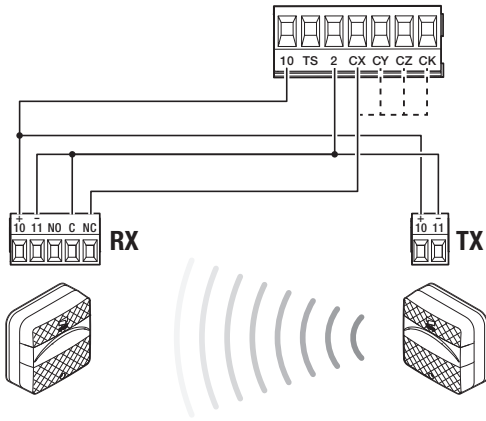

DELTA photocells

Connection with safety test

 See function F5, safety devices test.

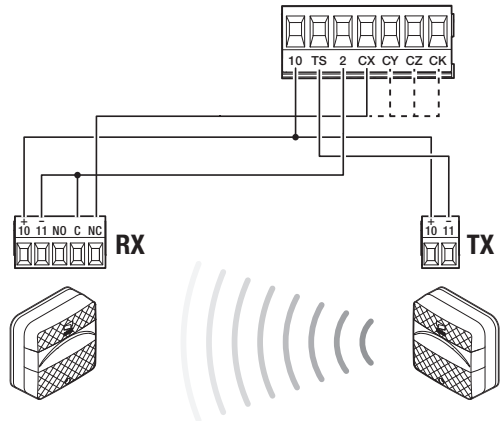

DIR / DELTA-S photocells

Standard connection

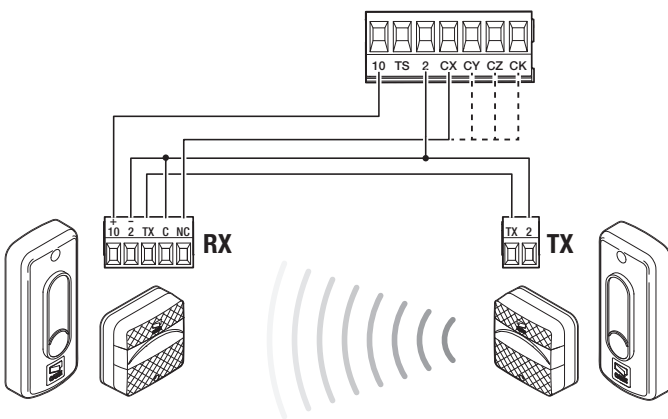

DIR / DELTA-S photocells

Connection with safety test

 See function F5, safety devices test.

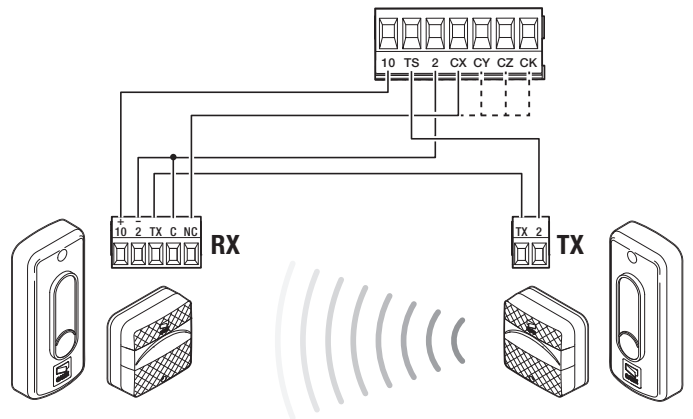

DFWN sensitive edge

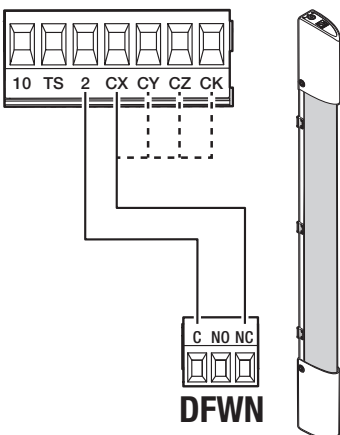

Pair of sensitive edges DFWN

Connected in parallel (recommended)

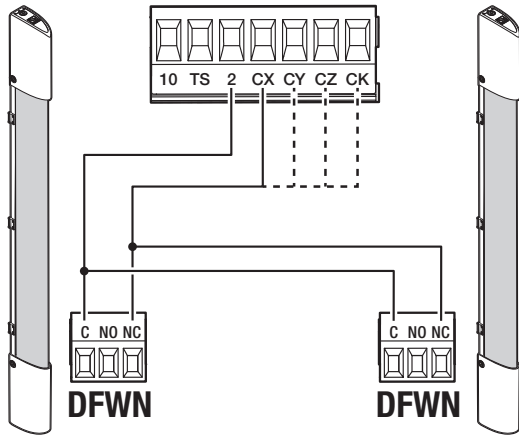

Pair of sensitive edges DFWN

Connected in series

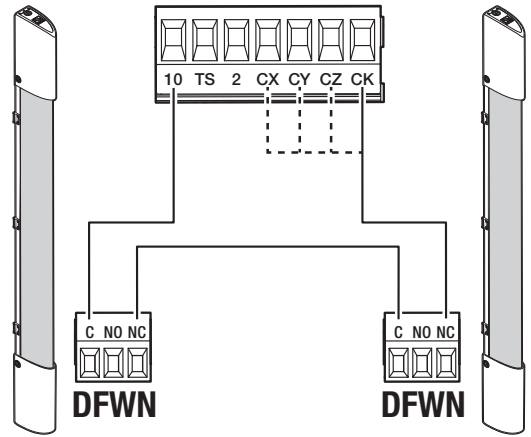

Programming button functions

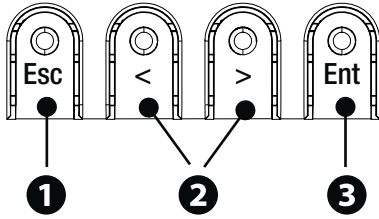

1 ESC button

The ESC button is used to perform the operations described below.
 Exit the menu
 Delete the changes
 Go back to the previous screen
 Stop the operator

2 <> buttons

The <> buttons are used to perform the operations described below.
 Navigate the menu
 Increase or decrease values
 Open or close the operator

3 ENTER button

The ENTER button is used to perform the operations described below.
 Access menus
 Confirm a choice

Getting started

- Once the electrical connections have been made, proceed with commissioning. Only skilled and qualified staff may perform this operation. Make sure that there are no obstacles in the way. Connect the device to the power supply and follow the wizard that appears on the display.
- After powering up the system, the first manoeuvre is always to open the gate; Wait for the manoeuvre to be completed.
- Press the STOP button immediately in the event of any faults, malfunctions, strange noises or vibrations, or unexpected behaviour in the system.

Functions menu

Opening direction

Set the gate opening direction.

Configuration Motor settings	Opening direction	To the left (Default) To the right
---------------------------------	-------------------	---------------------------------------

Motor test

Check the gate opens in the right direction.

If the buttons do not execute the commands correctly, invert the gate opening direction.

Configuration Motor settings	Motor test	The > button closes the gate The < button opens the gate
---------------------------------	------------	---

Travel calibration

Start the travel self-learning.

Configuration Motor settings	Travel calibration	Confirm? NO Confirm? YES
---------------------------------	--------------------	-----------------------------

Motor type

Set the type of gearmotor installed.

Configuration Motor settings	Motor type	BKV1500 BKV2000 BKV2500
---------------------------------	------------	-------------------------------

Opening speed

Set the opening speed (percentage of maximum speed).

Configuration Gate travel settings	Opening speed	40% to 100% (Default 100%)
---------------------------------------	----------------------	----------------------------

Closing speed

Sets the closing speed (percentage of maximum speed).

Configuration Gate travel settings	Closing speed	40% to 100% (Default 100%)
---------------------------------------	----------------------	----------------------------

Opening slowdown speed

Set the slowdown speed during opening (as a percentage of the maximum speed).

Configuration Gate travel settings	Opening slowdown speed	15% to 60% (Default 50%)
---------------------------------------	-------------------------------	--------------------------

Closing slowdown speed

Set the slowdown speed during closing (as a percentage of the maximum speed).

Configuration Gate travel settings	Closing slowdown speed	15% to 60% (Default 50%)
---------------------------------------	-------------------------------	--------------------------

Travel sensitivity

Adjust the obstruction detection sensitivity during boom travel.

Configuration Gate travel settings	Travel AST control	Deactivated (Default) Minimum Average Maximum Customised
---------------------------------------	---------------------------	--

Slowdown sensitivity

Adjust the obstacle-detection sensitivity level during slowdown.

Configuration Gate travel settings	Slowdown AST control	Deactivated (Default) Minimum Average Maximum Customised
---------------------------------------	-----------------------------	--

Soft start

Set a slowdown of a few seconds after each opening and closing command.

Configuration Gate travel settings	Soft start	Deactivated (Default) On
---------------------------------------	-------------------	-----------------------------

Partial opening point

Determine the gate partial opening point, as a percentage of total travel.

Configuration Gate travel settings	Part. open point	10% to 100% (20% Default)
---------------------------------------	-------------------------	---------------------------

Opening slowdown point

Set the opening slowdown start point, as a percentage of total travel.

Configuration Gate travel settings	Opening slowdown point	10% to 60% (Default 25%)
---------------------------------------	------------------------	--------------------------

Closing slowdown point

Set the closing slowdown start point, as a percentage of total travel.

Configuration Gate travel settings	Closing slowdown point	10% to 60% (Default 25%)
---------------------------------------	------------------------	--------------------------

Total stop

Stop the gate and exclude automatic closing. Use a control device to resume movement.

Configuration Wired safety devices	Total stop	Deactivated (Default) On
---------------------------------------	------------	-----------------------------

CX input

Associate a function with the CX input.

Configuration Wired safety devices	CX input	Deactivated (Default) C1 = Reopen while closing (photocells) C2 = Reclose while opening (photocells) C3 = Partial stop C4 = Obstacle standby (photocells) C7 = Reopen while closing (sensitive edges) C8 = Reclose while opening (sensitive edges) C13 = Reopen while closing, with immediate stop once the obstruction has been removed, even if the gate is not in motion R7 = Reopening during closure (sensitive edges with 8K2 resistor) R8 = Reclose while opening (sensitive edges with 8K2 resistor) R7 (two sensitive edges) = Reopen while closing (pair of sensitive edges with 8K2 resistor) R8 (two sensitive edges) = Reclose while opening (pair of sensitive edges with 8K2 resistor)
---------------------------------------	----------	--

CY input

Associate a function with the CY input.

Configuration Wired safety devices	CY input	Deactivated (Default) C1 = Reopen while closing (photocells) C2 = Reclose while opening (photocells) C3 = Partial stop C4 = Obstacle standby (photocells) C7 = Reopen while closing (sensitive edges) C8 = Reclose while opening (sensitive edges) C13 = Reopen while closing, with immediate stop once the obstruction has been removed, even if the gate is not in motion R7 = Reopening during closure (sensitive edges with 8K2 resistor) R8 = Reclose while opening (sensitive edges with 8K2 resistor) R7 (two sensitive edges) = Reopen while closing (pair of sensitive edges with 8K2 resistor) R8 (two sensitive edges) = Reclose while opening (pair of sensitive edges with 8K2 resistor)
---------------------------------------	----------	--

CZ input

Associate a function with the CZ input.

Configuration Wired safety devices	CZ input	Deactivated (Default) C1 = Reopen while closing (photocells) C2 = Reclose while opening (photocells) C3 = Partial stop C4 = Obstacle standby (photocells) C7 = Reopen while closing (sensitive edges) C8 = Reclose while opening (sensitive edges) C13 = Reopen while closing, with immediate stop once the obstruction has been removed, even if the gate is not in motion R7 = Reopening during closure (sensitive edges with 8K2 resistor) R8 = Reclose while opening (sensitive edges with 8K2 resistor) R7 (two sensitive edges) = Reopen while closing (pair of sensitive edges with 8K2 resistor) R8 (two sensitive edges) = Reclose while opening (pair of sensitive edges with 8K2 resistor)
--	-----------------	--

CK input

Associate a function with the CK input.

Configuration Wired safety devices	CK input	Deactivated (Default) C1 = Reopen while closing (photocells) C2 = Reclose while opening (photocells) C3 = Partial stop C4 = Obstacle standby (photocells) C7 = Reopen while closing (sensitive edges) C8 = Reclose while opening (sensitive edges) C13 = Reopen while closing, with immediate stop once the obstruction has been removed, even if the gate is not in motion R7 = Reopening during closure (sensitive edges with 8K2 resistor) R8 = Reclose while opening (sensitive edges with 8K2 resistor) R7 (two sensitive edges) = Reopen while closing (pair of sensitive edges with 8K2 resistor) R8 (two sensitive edges) = Reclose while opening (pair of sensitive edges with 8K2 resistor)
--	-----------------	--

Safety devices test

Check that the photocells connected to the inputs are operating correctly, after each opening and closing command.

Configuration Wired safety devices	Safety devices test	Deactivated (Default) On
--	----------------------------	-----------------------------

Obstacle with motor stopped

With the function active, the gate remains idle if the safety devices detect an obstacle. The function is active when the gate is closed, open or after a complete stop.

Configuration Wired safety devices	Obst. with motor stopped	Deactivated (Default) On
--	---------------------------------	-----------------------------

RIO ED T1

Associate one of the available functions to a wireless safety device.

The function only appears if there is an interface board for wireless devices.

Configuration RIO safety devices	RIO ED T1	Disabled (Default) P0 = It stops the gate and excludes automatic closing. Use a control device to resume movement. P7 = Reopen while closing. P8 = Reclose while opening.
--	------------------	--

RIO ED T2

Associate one of the available functions to a wireless safety device.

The function only appears if there is an interface board for wireless devices.

Configuration RIO safety devices	RIO ED T2	Disabled (Default) P0 = It stops the gate and excludes automatic closing. Use a control device to resume movement. P7 = Reopen while closing. P8 = Reclose while opening.
-------------------------------------	-----------	--

RIO PH T1

Associate one of the available functions to a wireless safety device.

The function only appears if there is an interface board for wireless devices.

Configuration RIO safety devices	RIO PH T1	Disabled (Default) P1 = Reopen while closing. P2 = Reclose while opening. P3 = Partial stop. P4 = Obstacle standby. P13 = Reopening during closure with immediate stop once the obstacle has been removed, even with the gate not in motion.
-------------------------------------	-----------	---

RIO PH T2

Associate one of the available functions to a wireless safety device.

The function only appears if there is an interface board for wireless devices.

Configuration RIO safety devices	RIO PH T2	Disabled (Default) P1 = Reopen while closing. P2 = Reclose while opening. P3 = Partial stop. P4 = Obstacle standby. P13 = Reopening during closure with immediate stop once the obstacle has been removed, even with the gate not in motion.
-------------------------------------	-----------	---

Command 2-7

Associate a command with the device connected to 2-7.

Configuration Command inputs	Command 2-7	Step-by-step (Default) Sequential
---------------------------------	-------------	--------------------------------------

Hold-to-run

With the function active, the operator stops moving (opening or closing) when the control device is released.

 When the function is active, it excludes all other control devices.

Configuration Functions	Hold-to-run	Deactivated (Default) On
----------------------------	-------------	-----------------------------

B1-B2 output

Configure the contact.

Configuration Functions	B1-B2 output	Bistable (Default) Monostable The contact remains closed for 1 to 180 seconds.
----------------------------	--------------	--

Removing obstacles

If an obstacle is detected by the sensitive edge or by the amperometric sensor on the electronic board, movement is inverted to create a space sufficient to clear the obstacle.

If this function is deactivated, the motion is inverted until the limit-switch is reached.

Configuration Functions	Removing obstacles	Deactivated (Default) On
-------------------------	--------------------	-----------------------------

Automatic closure

Set the time before automatic closure is activated, once the opening limit-switch has been reached.

 The function does not work if any of the safety devices are triggered when an obstacle is detected, or after a complete stop, or during a power outage.

Configuration Times	Automatic close	Deactivated (Default) From 1 to 180 seconds
---------------------	-----------------	--

Automatic closing after partial opening

Set the time before automatic closure is activated, after a partial opening command has been performed.

 The function does not work if any of the safety devices are triggered when an obstacle is detected, or after a complete stop, or during a power outage.

 Do not deactivate the function [Automatic close].

Configuration Times	Automatic partial close	Off 1 to 180 seconds (Default 10 seconds)
---------------------	-------------------------	--



Gate-open warning light

It signals the gate status.

Configuration Manage lights	Gate-open warning light	Warning light on (Default) - The warning light stays on when the gate is moving or open. Warning light flashing - The warning light flashes when the gate is moving and it stays on when the gate is open.
-----------------------------	-------------------------	---

Light E3

Choose the operating mode of the lighting device connected to the output.

Configuration Manage lights	Light E3	Deactivated (Default) Cycle lamp  The light remains off if an automatic closing time is not set. Courtesy light  The light remains on for the time set under the function [Courtesy time].
-----------------------------	----------	--

Courtesy time

Set the lighting device operation time.

Configuration Manage lights	Courtesy time	60 to 180 seconds (Default 60 seconds)
-----------------------------	---------------	--

Pre-flashing time

Set the time for which the beacon is activated before each manoeuvre.

Configuration Manage lights	Pre-flashing time	Deactivated (Default) From 1 to 10 seconds
-----------------------------	-------------------	---

RSE1

Configure the function to be performed by the card inserted in the RSE1 connector.

 If an RSE card – configured for paired connections – is plugged into the RSE_1 connector, use the RSE_2 connector for remote connection (CRP). In this case, a CAME KEY cannot be connected.

Configuration RSE communication	RSE1	CRP (Default) Paired Off
------------------------------------	------	--------------------------------

CRP address

Assign a unique identification code (CRP address) to the control board. It is used where there are multiple operators connected via CRP.

Configuration RSE communication	CRP address	1 to 254
------------------------------------	-------------	----------

RSE1 speed

Set the remote connection system communication speed on the RSE1 port.

Configuration RSE communication	RSE1 speed	1200 bps 2400 bps 4800 bps 9600 bps 14400 bps 19200 bps 38400 bps (Default) 57600 bps 115200 bps
------------------------------------	------------	--

RSE2 speed

Set the remote connection system communication speed on the RSE2 port.

Configuration RSE communication	RSE2 speed	1200 bps 2400 bps 4800 bps 9600 bps 14400 bps 19200 bps 38400 bps (Default) 57600 bps 115200 bps
------------------------------------	------------	--

Save data

Save user data, timings and configurations to the memory device (memory roll or USB key).

 The function is displayed only when a USB stick is inserted into the USB port or when a memory roll card is inserted into the control board.

Configuration External memory	Save data	
----------------------------------	-----------	--

Read data

Upload user data, timings and configurations from the memory device (memory roll or USB key).

 The function is displayed only when a USB stick is inserted into the USB port or when a memory roll card is inserted into the control board.

Configuration External memory	Read data	
----------------------------------	-----------	--

New user

Register up to a maximum of 250 users and assign a function to each one.

 The operation can be carried out by using a transmitter or another control device. The boards that manage the control devices (AF - R700 - R800) must be inserted into the connectors.

Manage users	New user	Step-by-step Sequential Open Partially open B1-B2 output Choose the function to be assigned to the user. Press ENTER to confirm. Send the code from the control device. Repeat the procedure to add other users.
--------------	----------	--

Remove user

Remove one of the registered users.

Manage users	Remove user	Use the arrows to choose the number associated with the user you want to remove. No.: 1 > 250 Alternatively, the control device associated with the user you want to remove can be activated. Press ENTER to confirm. "CLr" will appear to confirm deletion. Confirm? NO Confirm? YES
--------------	-------------	---

Remove all

Remove all registered users.

Manage users	Remove all	Confirm? NO Confirm? YES
--------------	------------	-----------------------------

Radio decoding

Choose the type of radio coding for the transmitters enabled to control the operator.

 If you choose the type of radio coding for the transmitters [Rolling code] or [TW key block], any transmitters with a different type of radio coding saved previously will be deleted.

Manage users	Radio decoding	All decodings Rolling code TW Key block Confirm? NO Confirm? YES
--------------	----------------	--

Sensor type

Set the type of control device.

Manage users	Sensor type	Keypad Transponder
--------------	-------------	-----------------------

Change mode

Change the function assigned to a specific user.

Manage users	Change mode	Select the user for whom you want to change the command.  You can select a user without using the arrows, by sending a command from the device associated with the user. Press ENTER to confirm. Choose the command to associate to the user. Press ENTER to confirm. Confirm? No Confirm? Yes
--------------	-------------	---

FW version

Display the firmware version number and the GUI installed.

Information	FW version	FW x.x.xx (firmware) GUI x.x (graphics)
-------------	------------	--

Manoeuvre counter

View the number of operator manoeuvres.

Total manoeuvres = Manoeuvres carried out since installation.

Partial manoeuvres = Manoeuvres carried out after the last one [Parameters reset].

Information	Manoeuvre counter	Total manoeuvres Partial manoeuvres
-------------	-------------------	--

Set up maintenance

Set the number of manoeuvres the operator can perform before a maintenance warning signal is generated. During a maintenance warning signal, the warning light flashes rhythmically 3 + 3 times [Open].

Information	Set up maintenance	Deactivated (Default) 1X100 to 250X100
-------------	--------------------	---

Maintenance reset

Reset the number of partial manoeuvres.

Information	Maintenance reset	Confirm? NO Confirm? YES
-------------	-------------------	-----------------------------

Parameter reset

Restore factory settings except for the functions: [Radio decoding], [Motor type] and the settings related to travel calibration.

Information	Parameter reset	Confirm? NO Confirm? YES
-------------	-----------------	-----------------------------

Errors list

View the last 8 errors detected. The error list can be deleted.

Information	Errors list	Use the arrows to scroll through the list. To cancel the error list, select [Delete errors] Press ENTER to confirm. Confirm? NO Confirm? YES
-------------	-------------	--

Show clock

Enable the clock on the display.

Timer management	Show clock	
------------------	------------	--

Set the clock

Set the date and time.

Timer management	Set the clock	Use the arrows and the Enter button to enter the desired values.
------------------	---------------	--

Automatic DST

Enable automatic daylight saving time setting.

Timer management	Automatic DST	Deactivated (Default) On
------------------	---------------	-----------------------------

Time format

Choose the clock display format.

Timer management	Time format	24-hour 12-hour
------------------	-------------	--------------------

Create new timer

Time one or more types of activation chosen from those available.

Timer management	Create new timer	Use the arrows to choose the desired function. Open / Partially open / Output B1-B2 Press ENTER to confirm. Use the arrows to set the start and end time of the function activation. Start time / end time Press ENTER to confirm. Use the arrows to set the function activation days Select days / Whole week Press ENTER to confirm.
------------------	------------------	--

Remove timer

Removes one of the saved timings.

Timer management	Remove timer	Use the arrows to choose the timing to be removed. O = [Opening] P = [Partial opening] B = [Output B1-B2] Press ENTER to confirm.
------------------	--------------	---

Commands

Run certain gate commands without the control devices.

Commands		Open Partially open Close Stop Use the arrows to select the command to be executed. Press ENTER to confirm.
----------	--	--

Language

Set the display language.

Language		Italiano (IT) English (EN) Français (FR) Deutsch (DE) Español (ES) Português (PT) Polski (PL) Русский (RU)
----------	--	---

Enable password

Set a 4-digit password. The password will be requested to anyone who wants to access the main menu.

Password	Enable password	Use the arrows and the Enter button to dial the desired code. Enter the password again using the arrows and the Enter button to confirm.
----------	-----------------	---

Forgotten password

If you forget your password, follow the procedure below.

Disconnect the control board from the power supply.

Press and hold the < and > buttons, then reconnect the control board to the power supply.

Continue to press and hold the < > buttons until [Factory reset] is displayed.

Select [Confirm YES].

Press ENTER to confirm.

 When you reset the control board, all saved users, set times and calibration operations are deleted.

Remove password

Remove the password that protects access to the main menu.

Password	Remove password	Confirm? NO Confirm? YES
----------	-----------------	-----------------------------

Change password

Change the 4-digit password that protects access to the main menu.

Password	Change password	Use the arrows and the Enter button to dial the desired code. Enter the password again using the arrows and the Enter button to confirm.
----------	-----------------	---

F Menu

Enable the F functions menu view.

Import/export data

Save user data and system configuration data on a MEMORY ROLL card.

The stored data can be reused for another control board to configure another system in the same way.

⚠ Before inserting and removing the MEMORY ROLL card, DISCONNECT THE MAINS POWER SUPPLY TO THE LINE.

- 1 Insert the MEMORY ROLL card into the corresponding connector on the control board.
- 2 Press the "Enter" button to access programming.
- 3 Use the arrows to choose the desired function.

 The functions are displayed only when a MEMORY ROLL card is inserted.

- Save data

Save user data, timings and configurations to the memory device (memory roll or USB key).

- Read data

Upload user data, timings and configurations from the memory device (memory roll or USB key).

 Once the data have been saved and loaded, remove the MEMORY ROLL card.

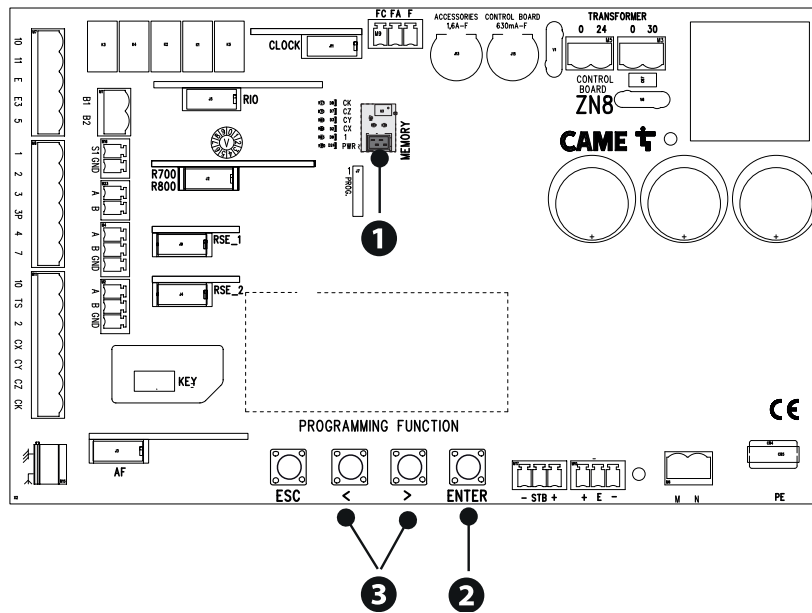

ERROR MESSAGES

Calibration error Interruption of the boom travel calibration due to the presence of an obstruction.

The Encoder does not work The Encoder is disconnected.
The Encoder is broken.

Service test failure error Presence of an obstruction within the range of the photocells.
The photocells are not correctly connected or configured.
The photocells are faulty.

Door lock open The operator is released.

Maximum number of closing obstacles The maximum number of obstacles detected consecutively has been exceeded

Maximum number of opening obstacles The maximum number of obstacles detected consecutively has been exceeded

Maximum number of obstacles The maximum number of obstacles detected consecutively has been exceeded

Communication error Configured on the wrong RSE port.

Incompatible remote control The transmitter used is not CAME.
The coding set is different from that of the transmitter.
The transmitters are TWIN and have different KEY BLOCK.

Slave door open The SLAVE operator is released.

No communication from the RIO system The wireless module is not plugged into the connector on the control board.
The wireless module is broken.

RIO system not configured The wireless system has not been configured.
The wireless devices have not been configured.

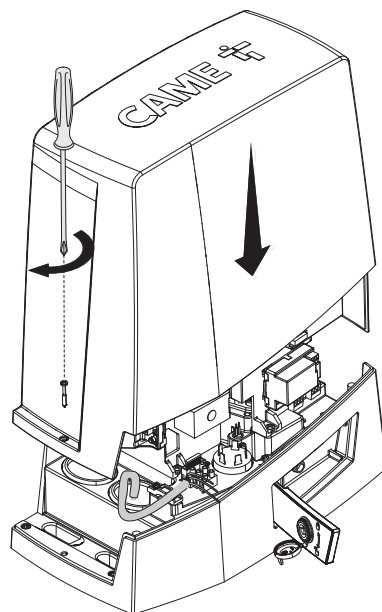
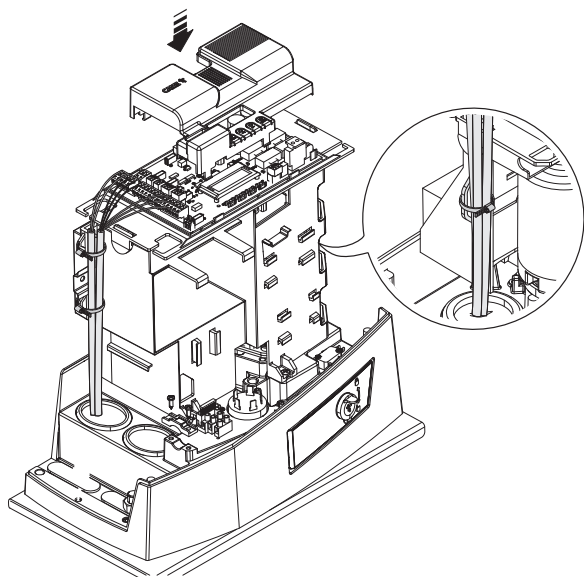

PAIRED OPERATION

Two connected operators are controlled with one command.

Electrical connections

Connect the two electronic boards with a UTP CAT 5 cable.

Fit an RSE card on both control boards, using the RSE_1 connector.

Connect up the electrics for the devices and accessories.

 The devices and accessories must be connected to the control board which will be set as the MASTER.

 For information on connecting the electrics for the devices and accessories, please see the "ELECTRICAL CONNECTIONS" section.

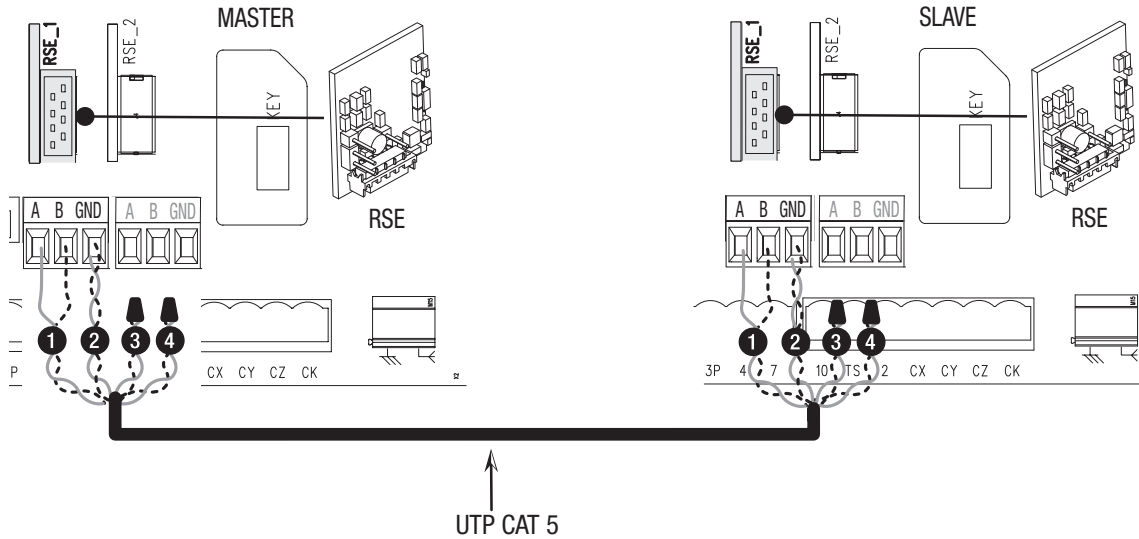

Programming

 All programming operations described below must be performed only on the control board set as the MASTER.

Select the [Paired] system type when following the guided procedure, or configure the RSE_1 port to [Paired] mode.

 After programming the MASTER operator in [Paired], the second operator automatically becomes SLAVE.

Saving users

 All save user operations must be performed only on the control board set as the MASTER.

Operating modes

❶ PARTIAL OPENING command

❷ STEP-BY-STEP or OPEN ONLY command

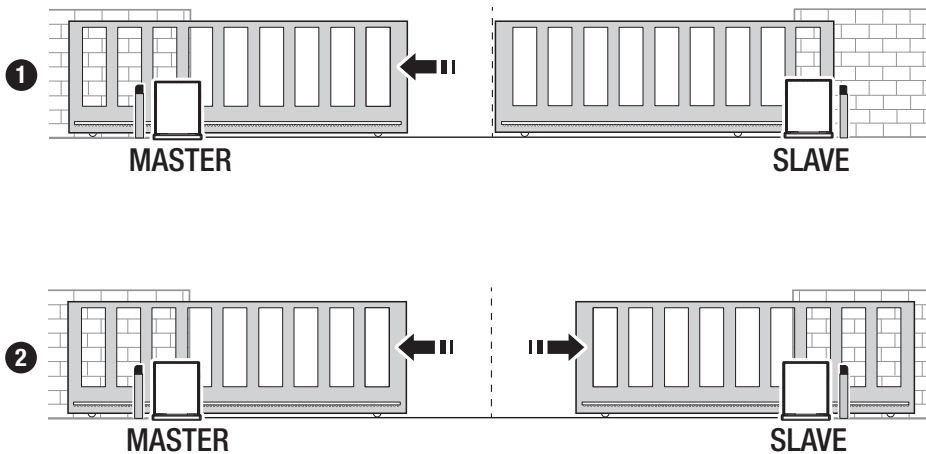

MCBF

Models	BKV15	BKV20	BKV25
20 m - 1500 kg	250000	-	-
20 m - 2000 kg	-	250000	-
20 m - 2500 kg	-	-	250000
Installation in windy area	-15%	-15%	-15%

 The percentages indicate how much the number of cycles should be reduced in relation to the type and number of accessories installed.

 Before carrying out any cleaning or maintenance, or replacing any parts, disconnect the device from the power supply.

 This document informs the installer of the checks that must be carried out during maintenance.

 If the system is not used for long periods of time, e.g. for installations at sites with seasonal closures, disconnect the power supply. When the power supply is reconnected, check the system is working correctly.

 For information on correct installation and adjustments, please see the product installation manual.

 For information on choosing products and accessories, please see our product catalogue.

 Every 10,000 cycles and, in any case, every 6 months of operation, you must perform the maintenance work indicated below.

Perform a general and complete check of the tightness of the nuts and bolts.

Grease all of the moving mechanical parts.

Check the warning and safety devices are working properly.

Check for any wear on the moving mechanical parts and check that they are working properly.

Check the release mechanism is working efficiently by performing a manoeuvre with the leaf free. The gate leaf must not be obstructed.

Check the cables are intact and connected correctly.

Check and clean the slide guide and rack.

Fabbricante / Manufacturer / Hersteller / Fabricant / Fabricante / Fabricante
/ Wytwórca / Fabrikant

Came S.p.a.

indirizzo / address / adresse / adresse / direccìon / endereço / adres / adres
Via Martiri della Libertà 15 - 31030 Dosson di Casier, Treviso - Italy



DICHIARA CHE LE AUTOMAZIONI PER CANCELLI SCORREVOLI / DECLARES THAT THE DRIVES FOR SLIDING GATES /
ERKLÄRT DASS DIE AUTOMATISIERUNGEN FÜR SCHIEBETÖRE / DECLARE QUE LES AUTOMATISATIONS POUR
PORTAILS COULISSANTS / DECLARA QUE LAS AUTOMATIZACIONES PARA PUERTAS CORREDERAS / DECLARA QUE AS
AUTOMATIZAÇÕES PARA PORTÕES DE CORRER / OSWADCZA ZE AUTOMATYKA DO BRAM PRZESUWNYCH /
VERKLAART DAT DE AUTOMATISERING VOOR SCHUIFHEKKEN

BKV15AGS ; BKV20AGS ; BKV25AGS
BKV15ALS ; BKV20ALS ; BKV25ALS
BKV15RGS ; BKV20RGS ; BKV15AGE
BKV20AGE ; BKV25AGE

SONO CONFORMI ALLE DISPOSIZIONI DELLE SEGUENTI DIRETTIVE / THEY COMPLY WITH THE PROVISIONS OF THE FOLLOW-
ING DIRECTIVES / DEN VORGABEN DER FOLGENDEN RICHTLINIEN ENTSPRECHEN / SONT CONFORMES AUX DISPOSITIONS
DES DIRECTIVES SUIVANTES / CUMPLEN CON LAS DISPOSICIONES DE LAS SIGUIENTES DIRECTIVAS / ESTÃO DE ACORDO
COM AS DISPOSIÇÕES DAS SEQUENTES DIRECTIVAS / SA ZGODNE Z POSTANOWIENIAMI NASTĘPUJĄCYCH DYREKTYW
EUROPEJSKICH / VOLDOEN AAN DE VOORSCHRIFTEN VAN DE VOLGENDE RICHTLIJNEN:

- COMPATIBILITÀ ELETTRROMAGNETICA / ELECTROMAGNETIC COMPATIBILITY / ELEKTROMAGNETISCHE
VERTRÄGLICHKEIT / COMPATIBILITÉ ÉLECTROMAGNETIQUE / COMPATIBILIDAD ELECTROMAGNETICA / COMPATIBIL-
DADE ELETROMAGNETICA / KOMPATYBILNOŚCI ELEKTROMAGNETYCZNEJ / ELEKTROMAGNETISCHE COMPATIBI-
LITEIT : 2014/30/UE.

Riferimento norme armonizzate ed altre norme tecniche / Refer to
European regulations and other technical regulations / Harmonisierte
Bezugsnormen und andere technische Vorgaben / Référence aux normes
harmonisées et aux autres normes techniques / Referencia normas
armonizadas y otras normas técnicas / Referência de normas harmoniza-
das e outras normas técnicas / Odnosne normy ujednoliconé i inne normy
techniczne / Geharmoniseerde en andere technische normen waarnaar is
verwezen

EN 61000-6-2:2005
EN 61000-6-3:2007+A1:2011
EN 62233:2008
EN 60335-1:2012+A11:2014
EN 60335-2-103:2015

RISPETTANO I REQUISITI ESSENZIALI APPLICATI / MEET THE APPLICABLE ESSENTIAL REQUIREMENTS / DEN WESENTLIJHEN
ANGEWANDTEN ANFORDERUNGEN ENTSPRECHEN / RESPECTENT LES CONDITIONS REQUISES NECESSAIRES APPLIQUEES /
/ CUMPLEN CON LOS REQUISITOS ESSENCIALES APLICADOS / RESPETAM O REQUISITOS ESSENCIAIS APLICADOS /
SPEŁNIĄJA PODSTAWOWE WYMAGANIA WYRUNKI / VOLDOEN AAN DE TOEPASBARE MINIMUM EISEN:

1.1.3; 1.1.5; 1.2.1; 1.2.2; 1.3.2; 1.3.7; 1.3.8.1; 1.4.1; 1.4.2; 1.5.1; 1.5.6; 1.5.8; 1.5.9; 1.5.9; 1.5.13; 1.6.1; 1.6.3; 1.6.4;
1.7.1; 1.7.2; 1.7.4

PERSONA AUTORIZZATA A COSTITUIRE LA DOCUMENTAZIONE TECNICA PERTINENTE / PERSON AUTHORISED TO COMPILE THE RELEVANT TECHNICAL DOCUMENTATION /
PERSON DIE BEVOLLMÄCHTIGT IST, DIE RELEVANTEN TECHNISCHEN UNTERLAGEN ZUSAMMENZUSTELLEN / DOCUMENTATION TECHNIQUE SPECIFIQUE D'AUTORISATION
A CONSTRUIRE DE / PERSONA FACULTADA PARA ELABORAR LA DOCUMENTACIÓN TÉCNICA PERTINENTE / PESSOA AUTORIZADA A CONSTITUIR A DOCUMENTAÇÃO TÉCNICA
PERTINENTE / OSOBA UPOWAZNIONA DO ZREDAGOWANIA DOKUMENTACJI TECHNICZNEJ / DIEGENE DIE GEMACHTIGT IS DE RELEVANTE TECHNISCHE DOCUMENTEN
SAMEN TE STELLEN.

CAME S.p.a.

La documentazione tecnica pertinente è stata compilata in conformità all'allegato VIB. / The pertinent technical documentation has been drawn up in compliance with attached
document VIB. / Die relevante technische Dokumentation wurde entsprechend der Anlage VIB ausgestellt. / La documentation technique spécifique a été remplie conformément à
l'annexe VIB. / La documentación técnica pertinente ha sido rellenada en cumplimiento con el anexo VIB. / A documentação técnica pertinente foi preenchida de acordo com o anexo
VIB. / Odnosna dokumentacja techniczna została zredagowana zgodnie z załącznikiem VIB. / De technische documentatie terzake is opgesteld in overeenstemming met de bijlage VIB.

CAME S.p.a. si impegna a trasmettere, in risposta a una richiesta adeguatamente motivata delle autorità nazionali, informazioni pertinenti sulle quasi macchine, e / Came S.p.a., following
a duly motivated request from the national authorities, undertakes to provide information related to the quasi machines, and / Die Firma Came S.p.a. verpflichtet sich auf eine angemessen
motiviertes Anfrage der staatlichen Behörden Informationen über die unvollständigen Maschinen, zu übermitteln, und / Came S.p.a. s'engage à transmettre, en réponse à une demande
bien fondée de la part des autorités nationales, les renseignements relatifs aux quasi machines. / Came S.p.a. se compromete a transmitir, como resposta a una solicitud adecuadamente
fundada por parte de las autoridades nacionales, informaciones relacionadas con las cuasimáquinas. / Came S.p.a. compromete-se em transmitir, em resposta a uma solicitação motivada
apropriadamente pelas autoridades nacionais, informações pertinentes às partes que compoñam máquinas. / Came S.p.a. zobowiązuje się do udzielenia informacji dotyczących maszyn
nieukończonych na odpowiednio umotywowana prośbę, złożoną przez kompetentne organy państwowe. / Came S.p.a. verbindt zich ertoe om op met redenen omkleed verzoek van de
nationale autoriteiten de relevante informatie voor de niet voltooidde machine te verstrekken.

VIETA / FORBIDS / VERBIETET / INTERDIT / PROHIBE / PROIBE / ZABRANIA SIE / VERBIEDT

la messa in servizio finché la macchina finale in cui deve essere incorporata non è stata dichiarata conforme, se dal caso alla 2006/42/CE. / commissioning of the above mentioned until such
moment when the final machine into which they must be incorporated, has been declared compliant, it pertains, to 2006/42/CE / die Inbetriebnahme bevor die „Endmaschine“ in die die
unvollständige Maschine eingebaut wird, als konform erklärt wurde, gegebenenfalls gemäß der Richtlinie 2006/42/EU. / la mise en service tant que la machine finale dans laquelle elle doit
être incorporée n'a pas été déclarée conforme, le cas échéant, à la norme 2006/42/CE. / la puesta en servicio hasta que la máquina final en la que será incorporada no haya sido declarada
de conformidad de acuerdo a la 2006/42/CE / a colocação em funcionamento, até que a máquina final, onde devem ser incorporadas, não for declarada em conformidade, se de acordo
com a 2006/42/CE. / Uruchomienia urządzenia do czasu, kiedy maszyna, do której ma być wbudowany, nie zostanie oceniona jako zgodna z wymogami dyrektywy 2006/42/WE, jeśli taka
procedura była konieczna. / deze in werking te stellen zolang de eindmachine waarin de niet voltooidde machine moet worden ingebouwd in overeenstemming is verklaard, indien toepasselijk
met de richtlijn 2006/42/EG.

Dosson di Casier (TV)
9 Novembre / November / November /
November / Noviembre / Novembro /
Listopad / November 2018

Amministratore Delegato / Managing Director /
General Direktor / Directeur Général / Director General /
Administrador Delegado / Dyrektor Zarządzający /
Algemeen Directeur

Andrea Menuzzo

Fascicolo tecnico a supporto / Supporting technical dossier / Unterstützung technische Dossier / soutien dossier technique / apoya expediente
técnico / apoiar dossier técnico / wspieranie dokumentacji technicznej / ondersteunende technische dossier: 801MS-0320

Came S.p.a.

Via Martiri della Libertà, 15 - 31030 Dosson di Casier - Treviso - Italy - Tel. (+39) 0422 4940 - Fax (+39) 0422 4941
info@came.it - www.came.com

Cap. Soc. 1.610.000,00 € - C.F. e P.I. 03481280265 - VAT IT 03481280265 - REA TV 275359 - Reg Imp. TV 03481280265



CAME S.P.A.

Via Martiri della Libertà, 15
31030 Dosson di Casier
Treviso - Italy
Tel. (+39) 0422 4940
Fax (+39) 0422 4941

CAME.COM

Automatismes pour portails coulissants

FA01443-FR



BKV15AGE BKV20AGE BKV25AGE
BKV15AGS BKV20AGS BKV25AGS
BKV15ALS BKV20ALS BKV25ALS
BKV15RGS BKV20RGS

MANUEL D'INSTALLATION

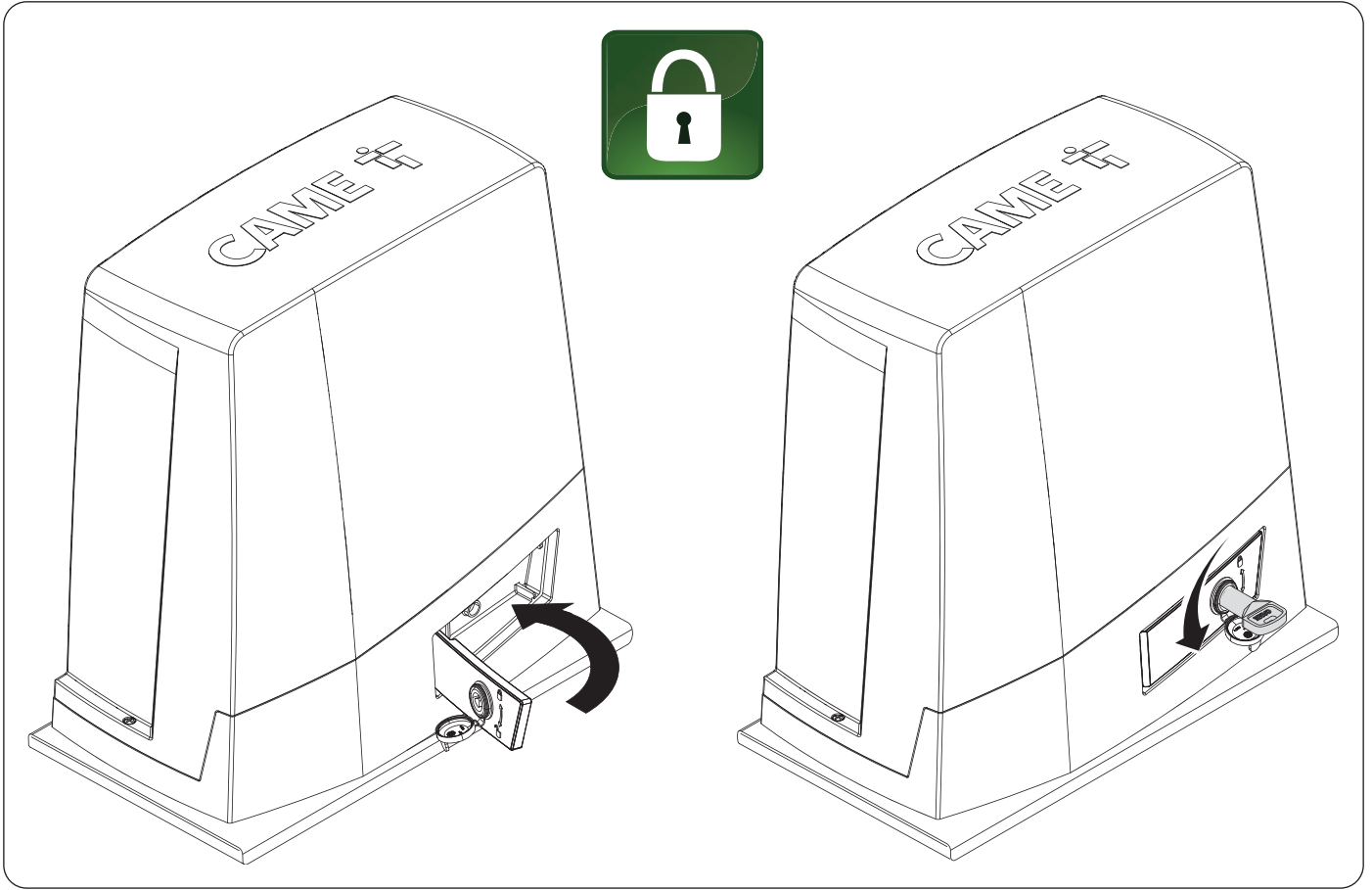
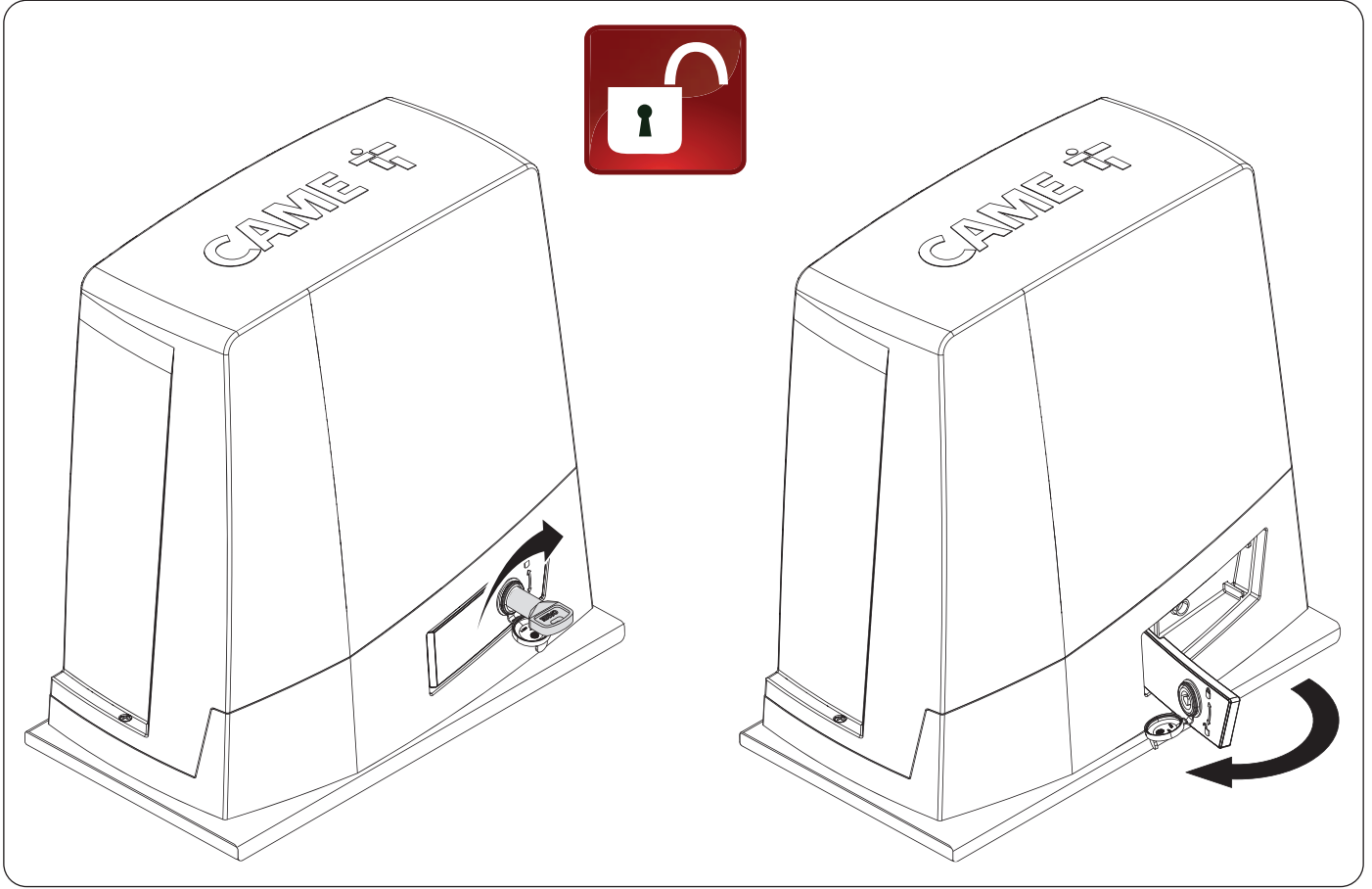

⚠ Consignes de sécurité importantes.

⚠ Suivre toutes les instructions étant donné qu'une installation incorrecte peut provoquer de graves lésions.

⚠ Avant toute opération, lire également les instructions générales réservées à l'utilisateur.

Ce produit ne devra être destiné qu'à l'utilisation pour laquelle il a été expressément conçu et toute autre utilisation est à considérer comme dangereuse. • Le fabricant décline toute responsabilité en cas d'éventuels dommages provoqués par des utilisations impropres, incorrectes et déraisonnables. • Le produit dont il est question dans ce manuel est défini, conformément à la Directive Machines 2006/42/CE, comme une quasi-machine. • La quasi-machine est, par définition, un ensemble qui constitue presque une machine, mais qui ne peut assurer à lui seul une application définie. • Les quasi-machines sont uniquement destinées à être incorporées ou assemblées à d'autres machines ou à d'autres quasi-machines ou équipements en vue de constituer une machine à laquelle s'applique la Directive Machines 2006/42/CE. • L'installation finale doit être conforme à la Directive Machines 2006/42/CE et aux normes européennes de référence. • Le fabricant décline toute responsabilité pour l'utilisation de produits non originaux, ce qui implique également l'annulation de la garantie. • Toutes les opérations indiquées dans ce manuel ne doivent être exécutées que par du personnel qualifié et dans le plein respect des normes en vigueur. • La position des câbles, la pose, la connexion et l'essai doivent être réalisés selon les règles de l'art et conformément aux normes et lois en vigueur. • S'assurer, durant toutes les phases d'installation, que l'automatisme est bien hors tension. • S'assurer que la température du lieu d'installation correspond à celle indiquée sur l'automatisme. • Ne pas installer l'automatisme dans des endroits en montée ou en descente (c'est-à-dire non situés sur une surface plane). • Ne pas installer l'automatisme sur des éléments susceptibles de se plier. Ajouter si nécessaire des renforts appropriés aux points de fixation. • Veiller à ce que le produit ne soit pas mouillé par des jets d'eau directs (arroseurs, nettoyeurs HP, etc.) sur le lieu d'installation. • Prévoir sur le réseau d'alimentation, conformément aux règles d'installation, un dispositif de déconnexion omnipolaire spécifique pour le sectionnement total en cas de surtension catégorie III. • Délimiter soigneusement toute la zone afin d'en éviter l'accès aux personnes non autorisées, notamment aux mineurs et aux enfants. • En cas de manutention manuelle, prévoir une personne tous les 20 kg à soulever ; en cas de manutention non manuelle, utiliser des instruments aptes à assurer le levage sécurisé. • Adopter des mesures de protection adéquates contre tout danger mécanique lié à la présence de personnes dans le rayon d'action de l'automatisme. • Les câbles électriques doivent passer à travers des tuyaux, des goulottes et des passe-câbles appropriés pour assurer une protection adéquate contre les dommages mécaniques. • Les câbles électriques ne doivent pas entrer en contact avec des parties pouvant devenir chaudes durant l'utilisation (ex. : moteur et transformateur). • Avant de procéder à l'installation, vérifier que la partie guidée est en bon état mécanique et qu'elle s'ouvre et se ferme correctement. • Le produit peut être utilisé pour automatiser une partie guidée intégrant un portillon uniquement s'il peut être actionné avec le portillon en position de sécurité. • S'assurer que l'actionnement de la partie guidée ne provoque aucun coincement avec les parties fixes présentes tout autour. • Prévoir une protection supplémentaire pour éviter l'écrasement des doigts entre le pignon et la crémaillère. • Les commandes fixes doivent toutes être clairement visibles après l'installation et être positionnées de manière à ce que la partie guidée soit directement visible mais à l'écart des parties en mouvement. Toute commande à action maintenue doit être installée à une hauteur minimum de 1,5 m par rapport au sol et doit être inaccessible au public. • À défaut d'étiquette, en appliquer une permanente qui décrit comment utiliser le mécanisme de déblocage manuel et la positionner près de l'élément d'actionnement. • S'assurer que l'automatisme a bien été réglé comme il faut et que les dispositifs de sécurité et de protection, tout comme le déblocage manuel, fonctionnent correctement. • Avant la livraison à l'utilisateur, vérifier la conformité de l'installation aux normes harmonisées et aux exigences essentielles de la Directive Machines 2006/42/CE. • Les éventuels risques résiduels doivent être signalés à l'utilisateur final par le biais de pictogrammes spécifiques bien en vue qu'il faudra lui expliquer. • Au terme de l'installation, appliquer la plaque d'identification de la machine dans une position bien en vue. • Si le câble d'alimentation est endommagé, son remplacement doit être effectué par le producteur, ou par son service d'assistance technique agréé, ou par une personne dûment qualifiée afin de prévenir tout risque. • Conserver ce manuel dans le dossier technique avec les manuels des autres dispositifs utilisés pour la réalisation du système d'automatisme. • Il est recommandé de remettre à l'utilisateur final tous les manuels d'utilisation des produits composant la machine.

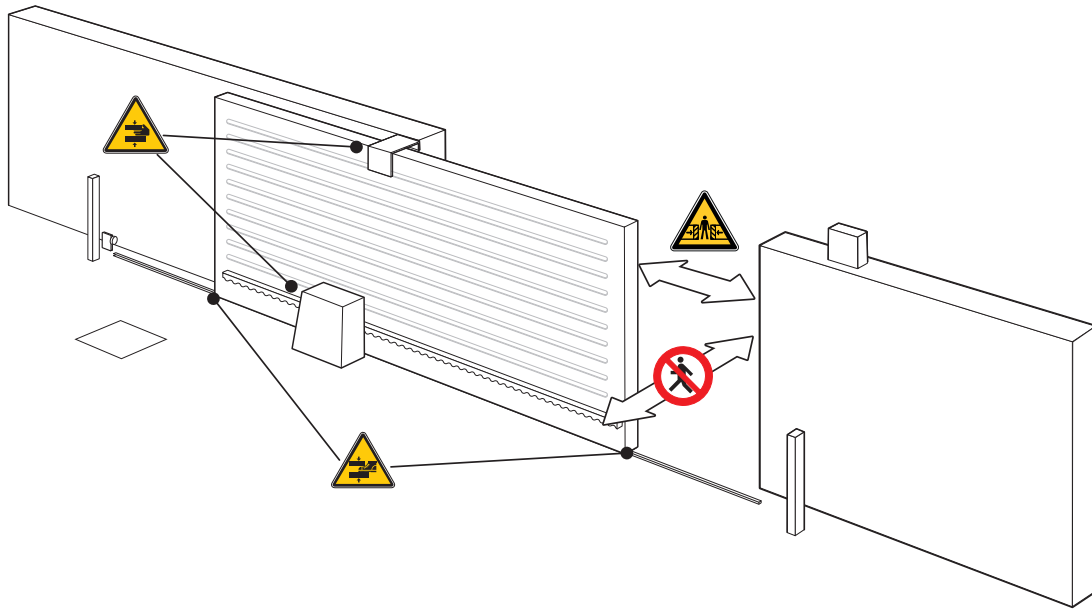

Passage interdit durant la manœuvre.



Danger de coincement.



Danger de coincement des mains.



Danger de coincement des pieds.

MISE AU REBUT ET ÉLIMINATION

CAME S.p.A. adopte dans ses établissements un Système de Gestion Environnementale certifié et conforme à la norme UNI EN ISO 14001 qui garantit le respect et la sauvegarde de l'environnement. Nous vous demandons de poursuivre ces efforts de sauvegarde de l'environnement, que CAME considère comme l'un des fondements du développement de ses propres stratégies opérationnelles et de marché, en observant tout simplement de brèves indications en matière d'élimination :

ÉLIMINATION DE L'EMBALLAGE

Les composants de l'emballage (carton, plastiques, etc.) sont assimilables aux déchets urbains solides et peuvent être éliminés sans aucune difficulté, en procédant tout simplement à la collecte différenciée pour le recyclage.

Avant d'effectuer ces opérations, il est toujours recommandé de vérifier les normes spécifiques en vigueur sur le lieu d'installation.

NE PAS JETER DANS LA NATURE !

ÉLIMINATION DU PRODUIT

Nos produits sont réalisés à partir de différents matériaux. La plupart de ces matériaux (aluminium, plastique, fer, câbles électriques) sont assimilables aux déchets urbains solides. Ils peuvent être recyclés au moyen de la collecte et de l'élimination différenciées auprès des centres autorisés.





D'autres composants (cartes électroniques, piles des émetteurs, etc.) peuvent par contre contenir des substances polluantes.

Il faut donc les désinstaller et les remettre aux entreprises autorisées à les récupérer et à les éliminer.

Avant d'effectuer ces opérations, il est toujours recommandé de vérifier les normes spécifiques en vigueur sur le lieu d'élimination.

NE PAS JETER DANS LA NATURE !

Légende

-  Ce symbole indique des parties à lire attentivement.
-  Ce symbole indique des parties concernant la sécurité.
-  Ce symbole indique ce qui doit être communiqué à l'utilisateur.
-  Les dimensions sont exprimées en millimètres, sauf indication contraire.

Description

801MS-0300

BKV15AGS - Automatisme avec moteur 36 V, carte électronique à afficheur graphique, Adaptive Speed & Torque Technology, 4 entrées de sécurité, gestion du mouvement et détection des obstacles pour portails jusqu'à 1500 kg et 20 m de long.

801MS-0310

BKV20AGS - Automatisme avec moteur 36 V, carte électronique à afficheur graphique, Adaptive Speed & Torque Technology, 4 entrées de sécurité, gestion du mouvement et détection des obstacles pour portails jusqu'à 2000 kg et 20 m de long.

801MS-0320

BKV25AGS - Automatisme avec moteur 36 V, carte électronique à afficheur graphique, Adaptive Speed & Torque Technology, 4 entrées de sécurité, gestion du mouvement/détection des obstacles et pignon module 6 pour portails jusqu'à 2500 kg et 20 m de long.

801MS-0330

BKV15RGS - Automatisme hautes performances avec moteur 36 V, carte électronique à afficheur graphique, Adaptive Speed & Torque Technology, 4 entrées de sécurité, gestion du mouvement et détection des obstacles pour portails jusqu'à 1500 kg et 20 m de long.

801MS-0340

BKV20RGS - Automatisme hautes performances avec moteur 36 V, carte électronique à afficheur graphique, Adaptive Speed & Torque Technology, 4 entrées de sécurité, gestion du mouvement et détection des obstacles pour portails jusqu'à 2000 kg et 20 m de long.

801MS-0350

BKV15AGE - Plus Automatisme hautes performances avec moteur 36 V, carte électronique à afficheur graphique, Adaptive Speed & Torque Technology, 4 entrées de sécurité, butées de fin de course magnétiques et accessoire clock inclus pour portails jusqu'à 1500 kg et 20 m de long.

801MS-0360

BKV20AGE - Plus Automatisme avec moteur 36 V, carte électronique à afficheur graphique, Adaptive Speed & Torque Technology, 4 entrées de sécurité, butées de fin de course magnétiques et accessoire clock inclus pour portails jusqu'à 2000 kg et 20 m de long.

801MS-0370

BKV25AGE - Plus Automatisme avec moteur 36 V, carte électronique à afficheur graphique, Adaptive Speed & Torque Technology, 4 entrées de sécurité, pignon module 6, butées de fin de course magnétiques et accessoire clock inclus pour portails jusqu'à 2500 kg et 20 m de long.

801MS-0301

BKV15ALS - Automatisme hautes performances avec moteur 36 V, carte électronique à afficheur graphique, Adaptive Speed & Torque Technology, 4 entrées de sécurité, gestion du mouvement et détection des obstacles pour portails jusqu'à 1500 kg et 20 m de long. Couvercle gris RAL 7040.

801MS-0311

BKV20ALS - Automatisme hautes performances avec moteur 36 V, carte électronique à afficheur graphique, Adaptive Speed & Torque Technology, 4 entrées de sécurité, gestion du mouvement et détection des obstacles pour portails jusqu'à 2000 kg et 20 m de long. Couvercle gris RAL 7040.

801MS-0321

BKV25ALS - Automatisme hautes performances avec moteur 36 V, carte électronique à afficheur graphique, Adaptive Speed & Torque Technology, 4 entrées de sécurité, gestion du mouvement/détection des obstacles et pignon module 6 pour portails jusqu'à 2500 kg et 20 m de long. Couvercle gris RAL 7040.

Utilisation prévue

Solution pour portails coulissants de grandes dimensions

 Toute installation et toute utilisation autres que celles qui sont indiquées dans ce manuel sont interdites.

Description des parties

Automatisme

- ❶ Couverture
- ❷ Couverture de protection de la carte
- ❸ Carte électronique
- ❹ Support porte-cartes
- ❺ Motoréducteur
- ❻ Fin de course mécanique
- ❼ Plaque de fixation
- ❽ Logement pour 2 batteries de secours
- ❾ Logement pour thermostat avec cartouche
- ❿ Logement pour module RGSM001
- ⓫ Logement pour carte LBB
- ⓬ Logement pour module RGP1
- ⓭ Levier de déblocage
- ⓮ Ailettes pour fin de course mécanique
- ⓯ Éléments de fixation
- ⓰ Logement pour module UR042
- ⓱ Orifices pour le passage des câbles électriques
- ⓲ Logement pour module SMA
- ⓳ Fin de course magnétique*
- ⓴ Ailettes pour fin de course magnétique*
- ⓵ Carte clock (806SA-0120)*

* Uniquement pour BKV15AGE, BKV20AGE et BKV25AGE

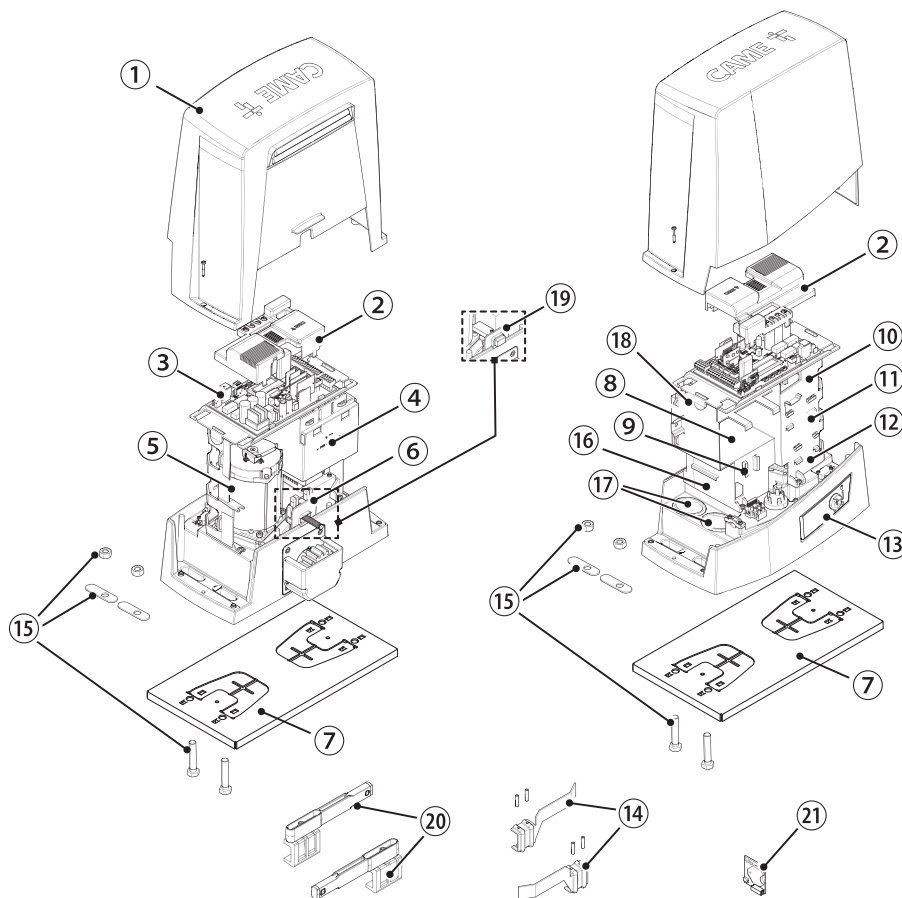

Carte électronique

Les fonctions sur les contacts d'entrée et de sortie, les réglages des temps et la gestion des utilisateurs sont configurés et visualisés sur l'afficheur.

Toutes les connexions sont protégées par des fusibles rapides.

⚠ Pour un fonctionnement correct, IL EST OBLIGATOIRE, avant d'enficher la carte, DE METTRE HORS TENSION et de déconnecter les éventuelles batteries.

⚠ Avant d'intervenir sur l'armoire de commande, mettre hors tension et déconnecter les éventuelles batteries.

- | | | | |
|----|---|----|---|
| 1 | Bornier de connexion du motoréducteur | 14 | Bornier de connexion des dispositifs de signalisation |
| 2 | Bornier de connexion de l'encodeur | 15 | Bornier pour la sortie B1-B2 |
| 3 | Bornier de connexion du module RGP1 ou carte LBB | 16 | Connecteur pour carte de décodage R700 ou R800 |
| 4 | Touches de programmation | 17 | Connecteur pour module RIOCN8WS |
| 5 | Connecteur pour carte RSE | 18 | Connecteur pour carte clock (806SA-0120) |
| 6 | Connecteur pour CAME KEY | 19 | Bornier pour micro-interrupteurs de fin de course |
| 7 | Connecteur pour carte radiofréquence enfichable (AF) | 20 | Fusible pour les accessoires |
| 8 | Bornier de connexion de l'antenne | 21 | Fusible pour la carte électronique |
| 9 | Bornier de connexion des dispositifs de sécurité | 22 | Bornier de connexion du transformateur |
| 10 | Bornier pour la connexion de la fonction vis-à-vis ou CRP | 23 | Connecteur pour carte Memory Roll |
| 11 | Bornier de connexion des dispositifs de commande | 24 | Afficheur |
| 12 | Bornier de connexion du clavier à code | 25 | Fusible de ligne |
| 13 | Bornier de connexion du sélecteur transpondeur | 26 | Bornier d'alimentation |

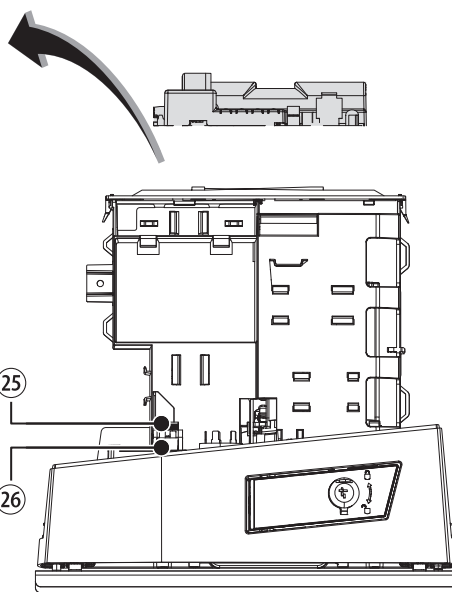
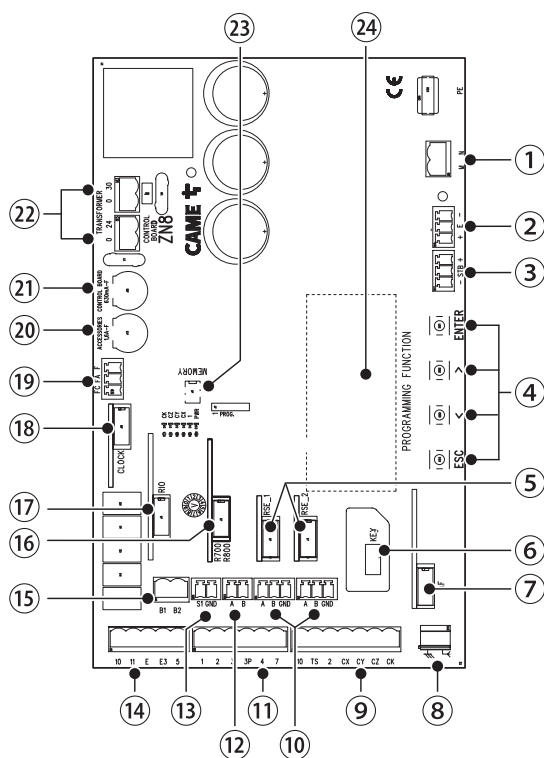

Pour pouvoir installer les cartes enfichables dans les connecteurs dédiés, enlever le couvercle de la carte.

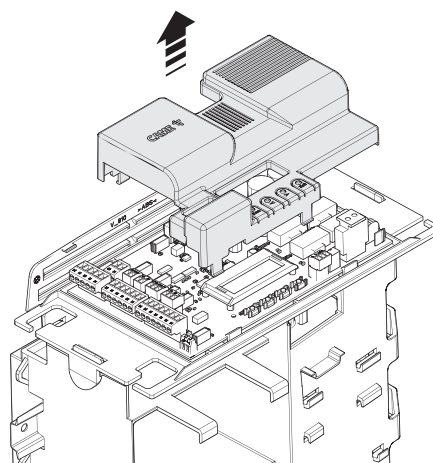
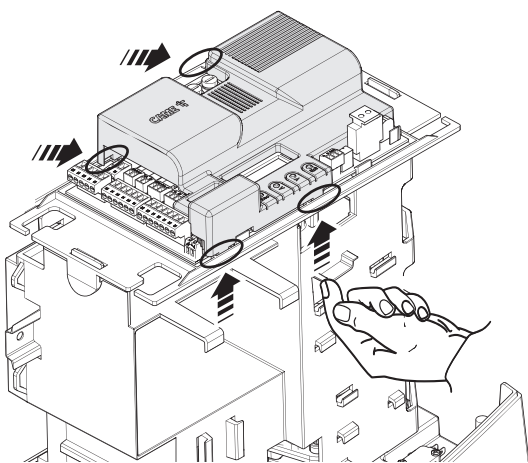

Dimensions

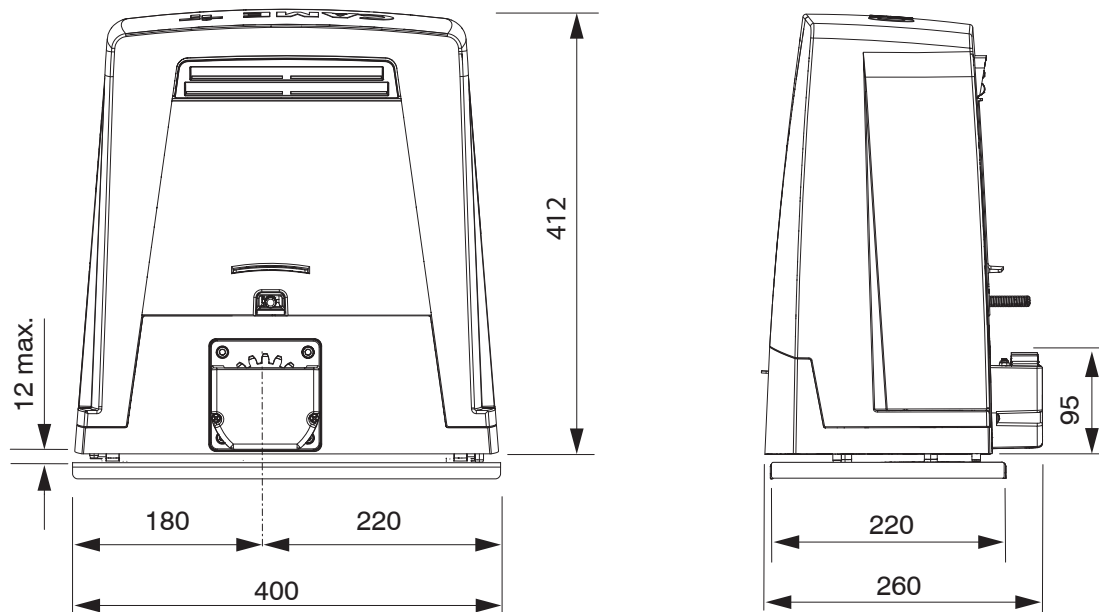

Limites d'utilisation

MODÈLES	BKV15AGS	BKV20AGS	BKV25AGS	BKV15RGS	BKV20RGS
Module du pignon	4	4	6	4	4
Longueur maximum vantail (m)	20	20	20	20	20
Poids maximum vantail (kg)	1500	2000	2500	1500	2000

MODÈLES	BKV15AGE	BKV20AGE	BKV25AGE	BKV15ALS	BKV20ALS	BKV25ALS
Module du pignon	4	4	6	4	4	6
Longueur maximum vantail (m)	20	20	20	20	20	20
Poids maximum vantail (kg)	1500	2000	2500	1500	2000	2500

Types de câbles et épaisseurs minimum

Longueur du câble (m)	jusqu'à 20	de 20 à 30
Alimentation 230 VAC	3G x 1,5 mm ²	3G x 2,5 mm ²
Feu clignotant 24 VAC/DC	2 x 1 mm ²	2 x 1 mm ²
Photocellules TX	2 x 0,5 mm ²	2 x 0,5 mm ²
Photocellules RX	4 x 0,5 mm ²	4 x 0,5 mm ²
Dispositifs de commande	*n° x 0,5 mm ²	*n° x 0,5 mm ²

*n° = voir les instructions de montage du produit - Attention : la section du câble est approximative car elle varie en fonction de la puissance du moteur et de la longueur du câble.

 En cas d'alimentation en 230 V et d'une utilisation en extérieur, adopter des câbles H05RN-F conformes à la norme 60245 IEC 57 (IEC) ; en intérieur, utiliser par contre des câbles H05VV-F conformes à la norme 60227 IEC 53 (IEC). Pour les alimentations jusqu'à 48 V, il est possible d'utiliser des câbles FROR 20-22 II conformes à la norme EN 50267-2-1 (CEI).

 Pour la connexion de l'antenne, utiliser un câble RG58 (jusqu'à 5 m).

 Pour la connexion vis-à-vis et CRP, utiliser un câble UTP CAT5 (jusqu'à 1000 m).

 Si la longueur des câbles ne correspond pas aux valeurs indiquées dans le tableau, déterminer la section des câbles en fonction de l'absorption effective des dispositifs connectés et selon les prescriptions de la norme CEI EN 60204-1.

 Pour les connexions prévoyant plusieurs charges sur la même ligne (séquentielles), les dimensions indiquées dans le tableau doivent être réévaluées en fonction des absorptions et des distances effectives. Pour les connexions de produits non indiqués dans ce manuel, considérer comme valable la documentation jointe à ces derniers.

INSTALLATION

Les illustrations suivantes ne sont que des exemples étant donné que l'espace pour la fixation de l'automatisme et des accessoires varie en fonction de la zone d'installation. C'est donc l'installateur qui doit choisir la solution la plus indiquée.

Les dessins illustrent l'automatisme installé à gauche.

Opérations préliminaires

Creuser la fosse pour le coffrage.

Préparer les gaines annelées pour les raccordements issus du boîtier de dérivation.

Il est conseillé de prévoir des gaines annelées $\varnothing 40$ mm pour la connexion du motoréducteur et des accessoires.

Le nombre de gaines dépend du type d'installation et des accessoires prévus.

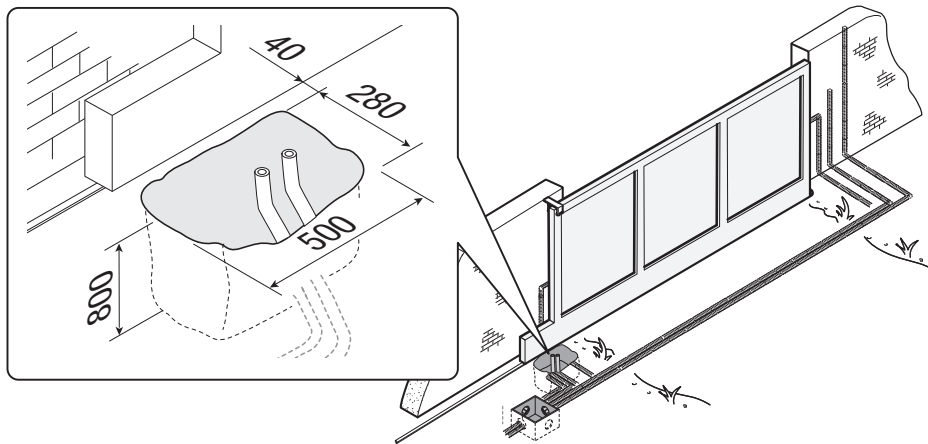

Pose de la plaque de fixation

Préparer un coffrage plus grand que la plaque de fixation.

Introduire le coffrage dans le trou.

Le coffrage doit dépasser de 50 mm du sol.

Insérer une grille en fer dans le coffrage pour couler le ciment.

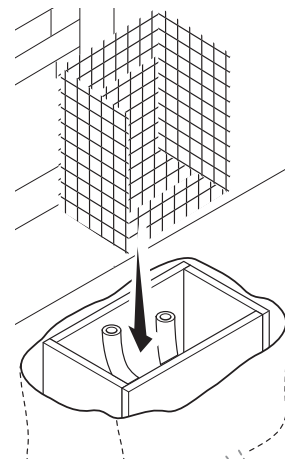
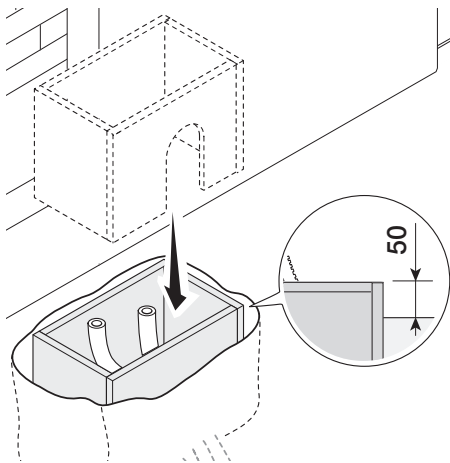

Insérer les vis fournies dans la plaque de fixation.
Bloquer les vis à l'aide des écrous fournis.
Extraire les agrafes préformées à l'aide d'un tournevis.
Introduire la plaque de fixation dans la grille en fer.

 Les tuyaux doivent passer à travers les trous prévus.

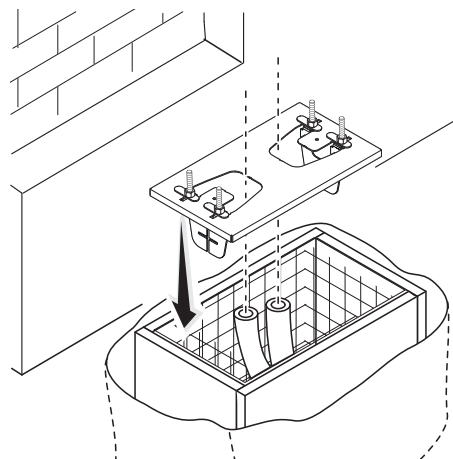
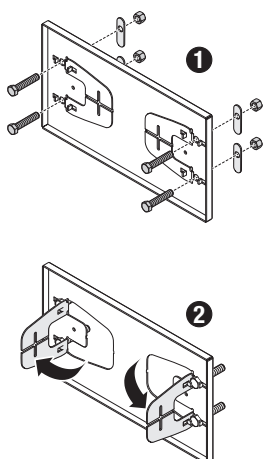

Positionner la plaque de fixation selon les dimensions indiquées sur le dessin.

 Si le portail est sans crémaillère, procéder à l'installation.

 Voir le paragraphe FIXATION DE LA CRÉMAILLÈRE.

Remplir le coffrage de ciment.

 La plaque doit être parfaitement nivelée et avec le filet des vis totalement en surface.

Attendre que le ciment se solidifie pendant au moins 24 heures.

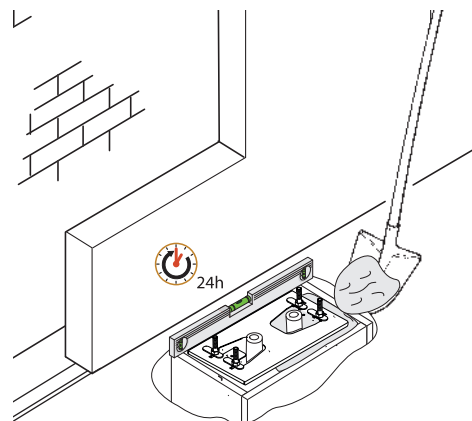
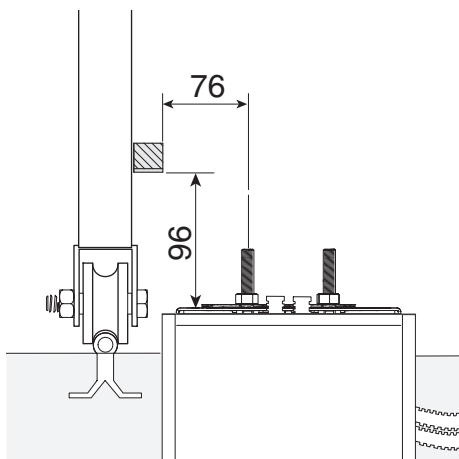

Enlever le coffrage.

Remplir de terre le trou autour du bloc de ciment.

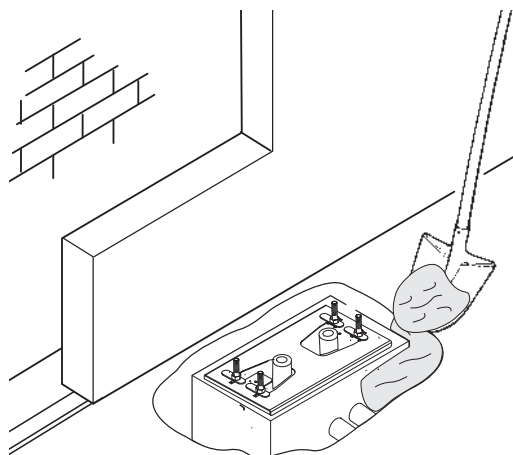
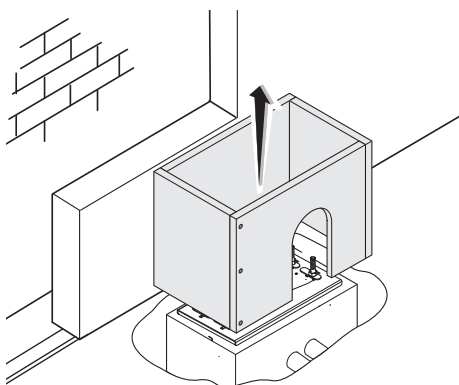

Enlever les écrous des vis.

Introduire les câbles électriques dans les gaines jusqu'à ce qu'ils sortent d'environ 600 mm.

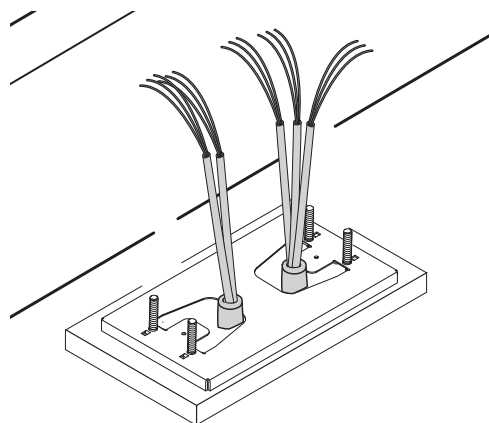
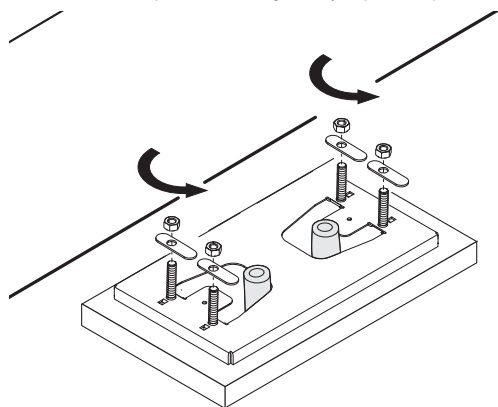

Préparation de l'automatisme

Enlever le couvercle de l'automatisme.

Positionner l'automatisme sur la plaque de fixation.

 Les câbles électriques doivent passer sous la caisse de l'automatisme.

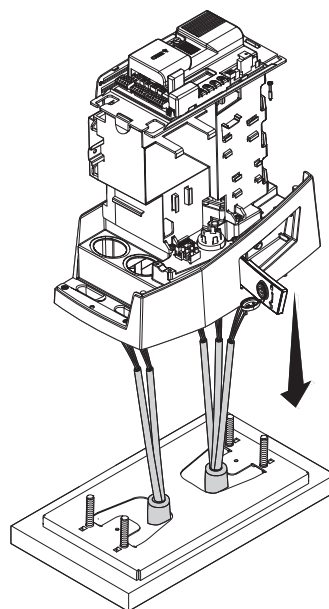
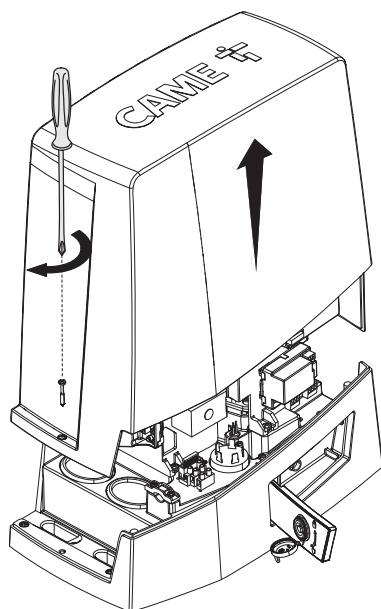

Percer le passe-câble.

Enfiler les câbles dans le passe-câble.

Soulever l'automatisme de 5 à 10 mm de la plaque en intervenant sur les pieds filetés afin de permettre, par la suite, les éventuels réglages entre pignon et crémaillère.

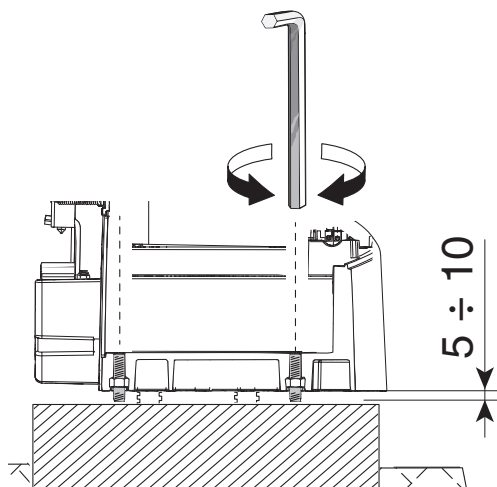
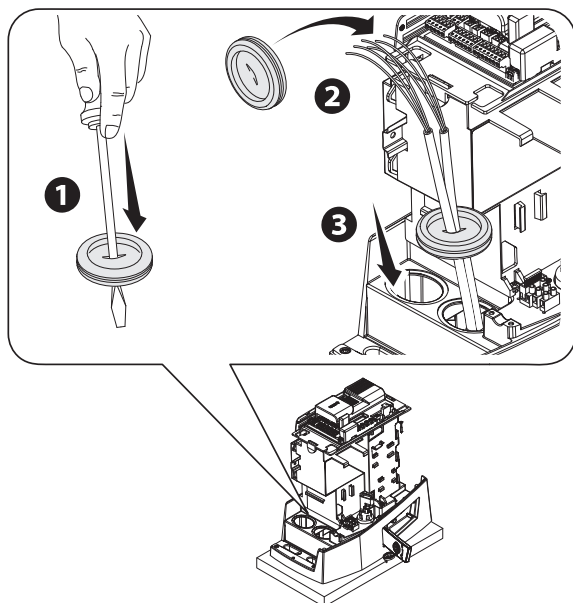

Fixation de la crémaillère

1 Débloquer l'automatisme.

2 Poser la crémaillère sur le pignon.

3 Souder ou fixer la crémaillère au portail sur toute sa longueur.

 Pour l'assemblage des modules de la crémaillère, positionner un morceau de rebut sous le point de jonction et le bloquer au moyen de deux mors.

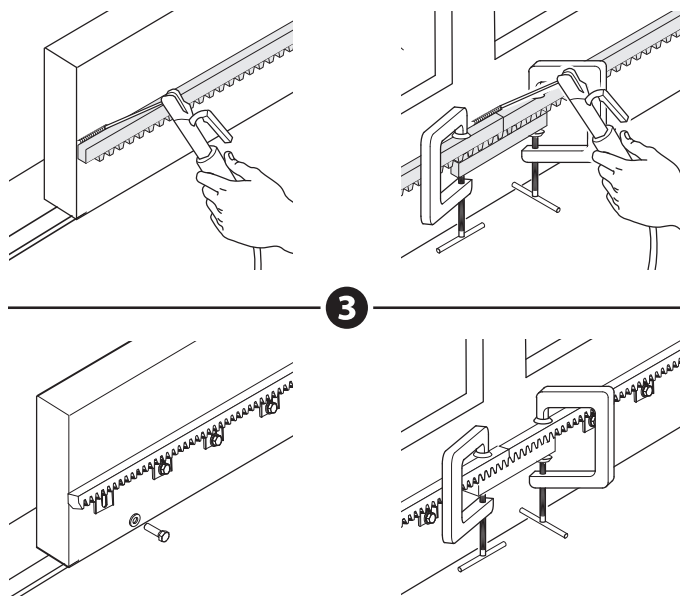
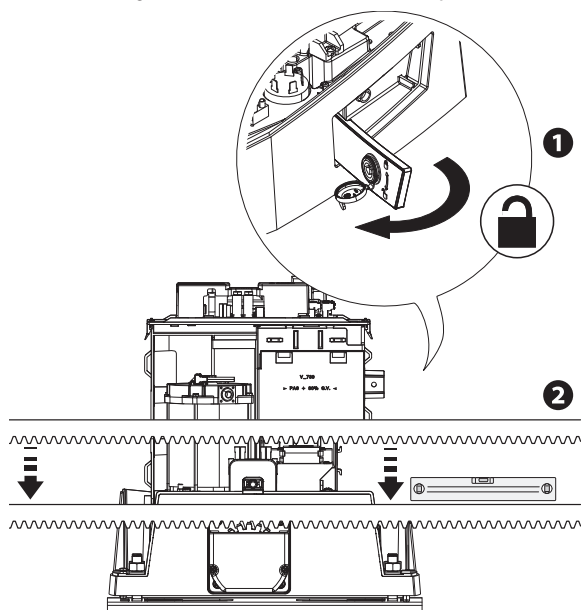

Réglage de l'accouplement pignon-crémaillère

Ouvrir et fermer le portail manuellement.

Régler la distance de l'accouplement pignon-crémaillère à l'aide des pieds filetés (réglage vertical) et des fentes (réglage horizontal).

 Le poids du portail ne doit pas peser sur l'automatisme.

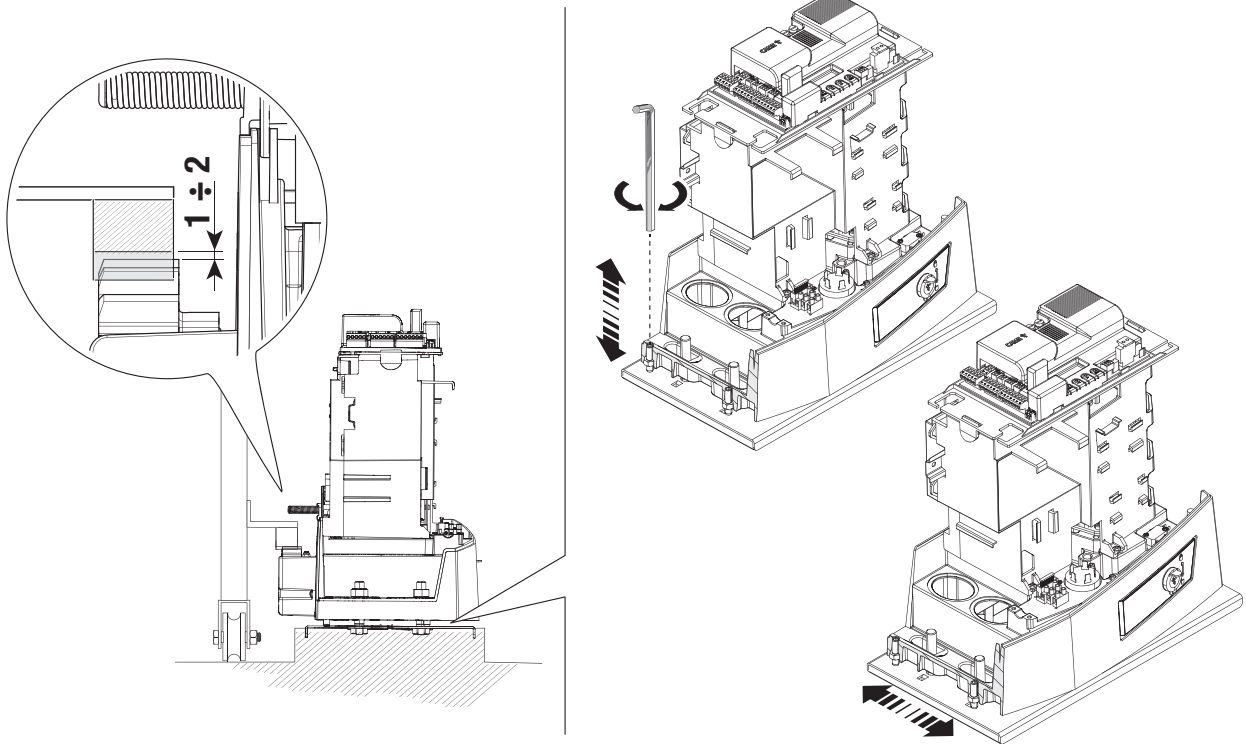

Fixation de l'automatisme

 Ne fixer qu'après avoir réglé l'accouplement pignon-crémaillère.

Fixer l'automatisme à la plaque de fixation à l'aide des butées et des écrous.

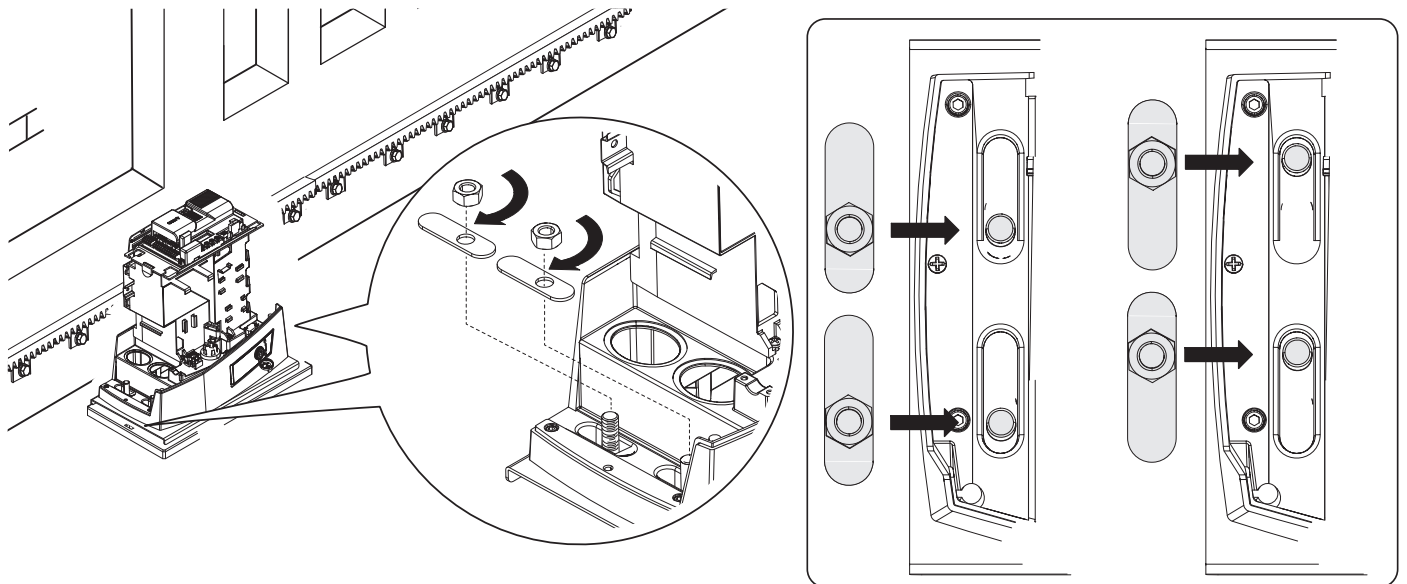

Définition des points de fin de course avec butées de fin de course mécaniques

- 1 Ouvrir le portail.
- 2 Glisser l'ailette de la butée de fin de course d'ouverture sur la crémaillère.
Le ressort doit faire déclencher le micro-interrupteur.
- 3 Fixer l'ailette de fin de course d'ouverture à l'aide des vis sans tête (fournies).

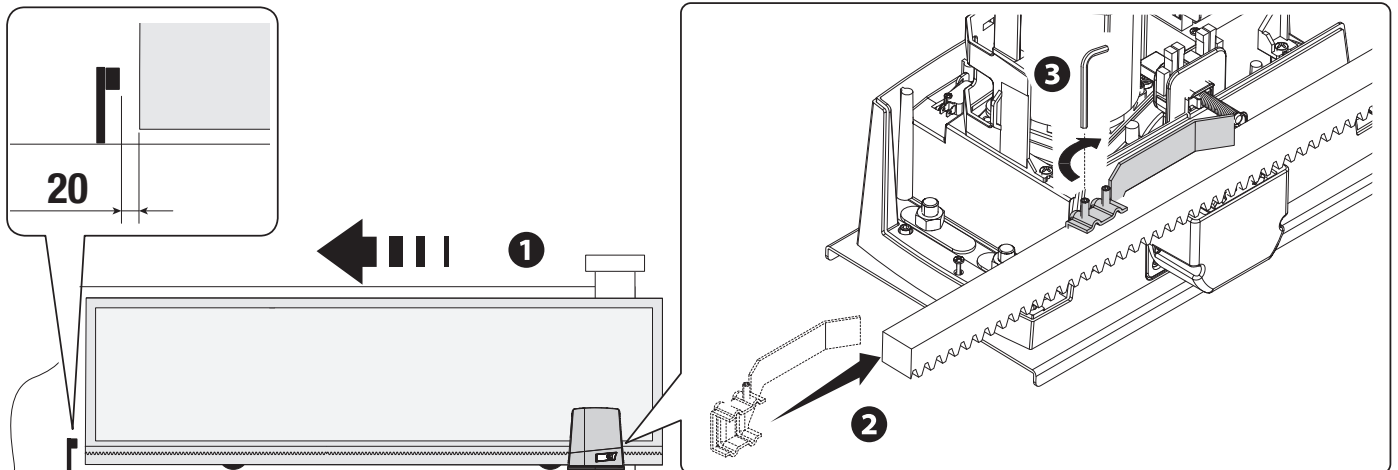

- 4 Fermer le portail.
- 5 Glisser l'ailette de fin de course de fermeture sur la crémaillère.
Le ressort doit faire déclencher le micro-interrupteur.
- 6 Fixer l'ailette de fin de course de fermeture à l'aide des vis sans tête (fournies).

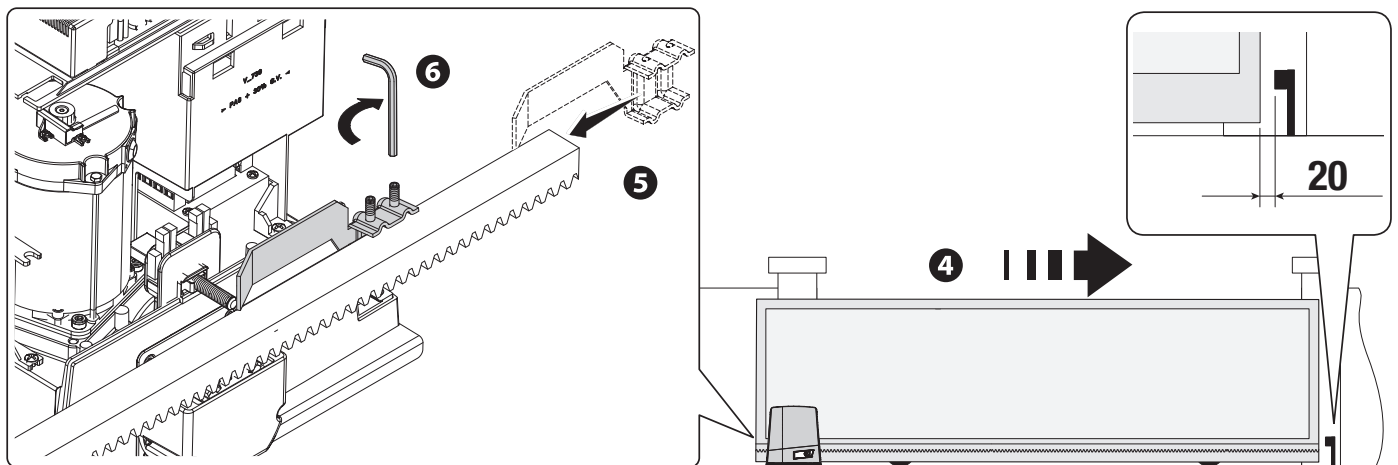

Définition des points de fin de course avec butées de fin de course magnétiques

* Uniquement pour BKV15AGE, BKV20AGE et BKV25AGE

- A** Ailette pour fin de course magnétique en fermeture
- B** Ailette pour fin de course magnétique en ouverture

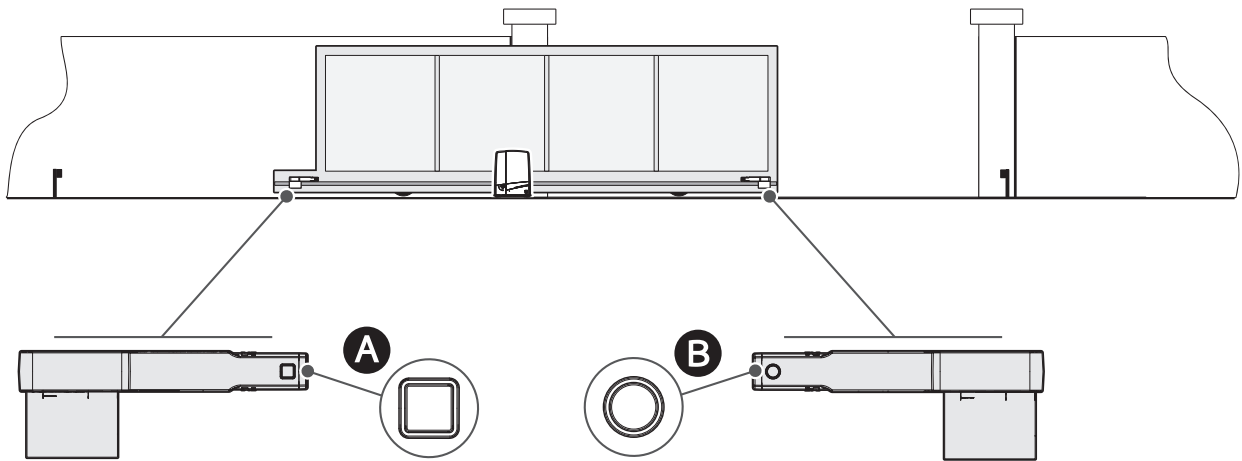

Ouvrir le portail.

Glisser l'ailette magnétique de fin de course d'ouverture sur la crémaillère.

L'aimant de l'ailette doit rester à une distance comprise entre 10 et 30 mm du capteur magnétique.

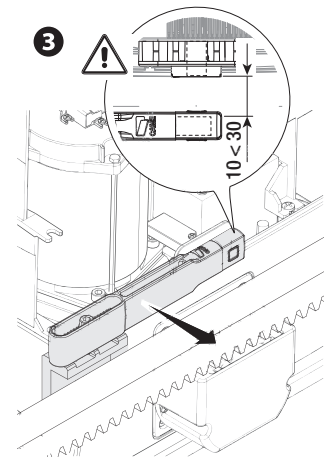
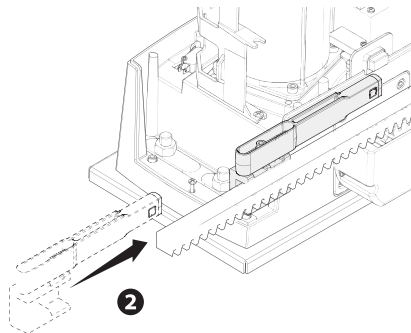
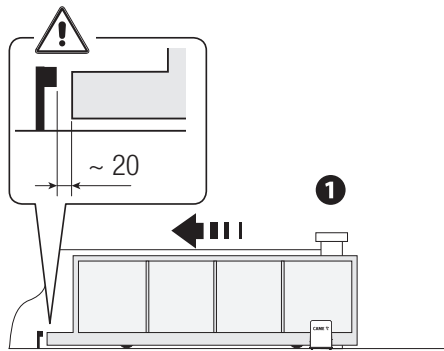

Fixer le support sur la crémaillère à l'aide des vis sans tête (fournies).

L'aimant de l'ailette de fin de course doit être perpendiculaire au capteur magnétique.

Fixer l'ailette de fin de course à l'aide de la vis (fournie).

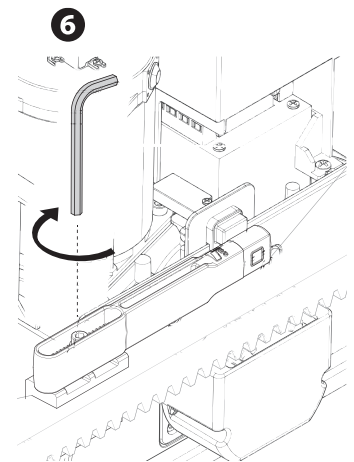
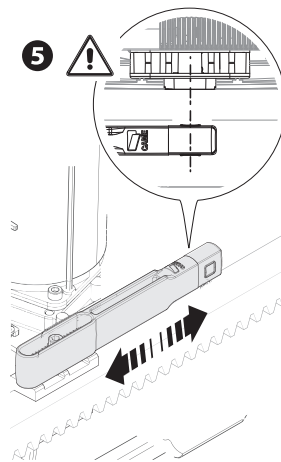
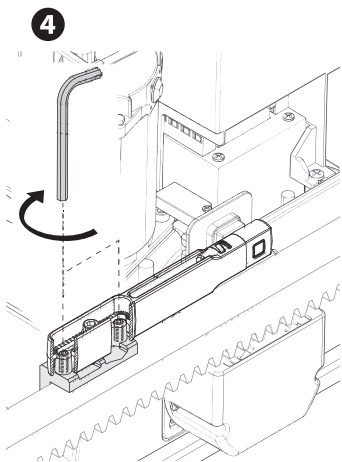

Fermer le portail.

Glisser l'aillette magnétique de fin de course de fermeture sur la crémaillère.

 L'aimant de l'aillette doit rester à une distance comprise entre 10 et 30 mm du capteur magnétique.

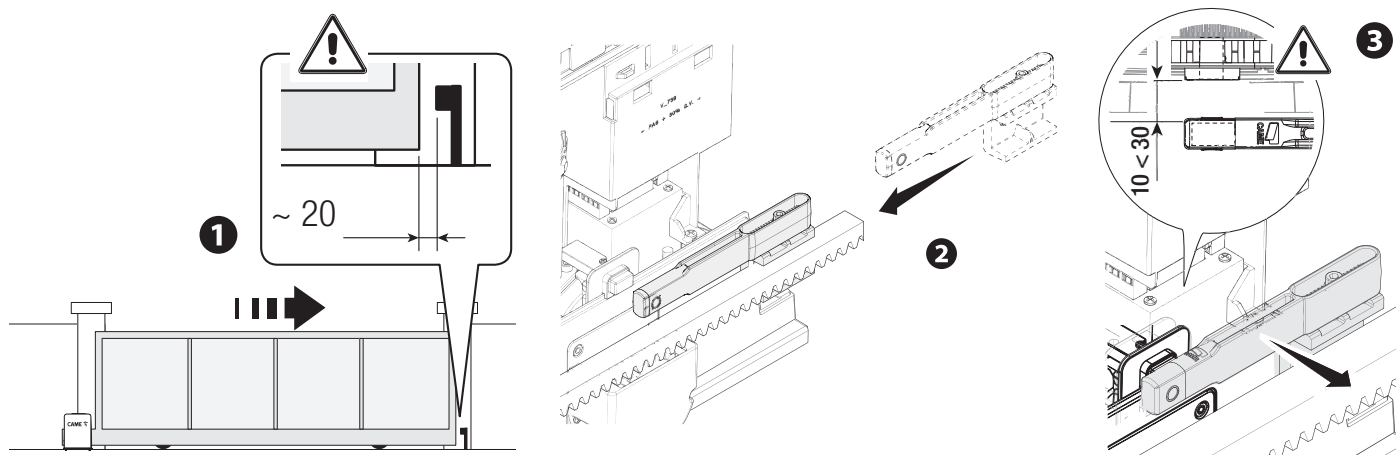

Fixer le support sur la crémaillère à l'aide des vis sans tête (fournies).

 L'aimant de l'aillette de fin de course doit être perpendiculaire au capteur magnétique.

Fixer l'aillette de fin de course à l'aide de la vis (fournie).

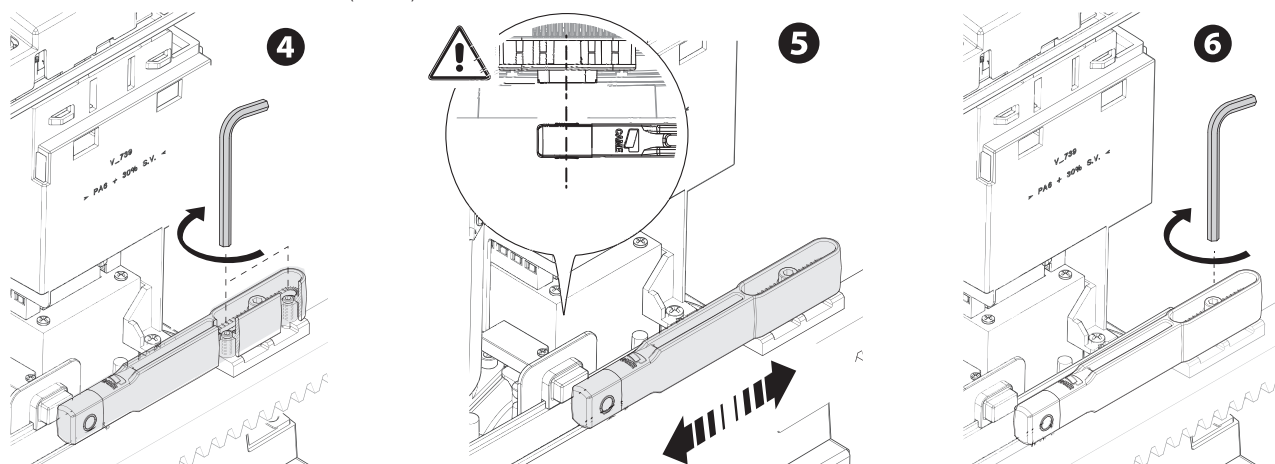

Passage des câbles électriques

Effectuer les branchements électriques selon les dispositions en vigueur.

Les câbles électriques ne doivent pas entrer en contact avec des parties pouvant devenir chaudes durant l'utilisation (ex. : moteur et transformateur).

Utiliser des passe-câbles pour connecter les dispositifs à l'armoire de commande. Un de ces passe-câbles ne doit être destiné qu'au cordon d'alimentation.

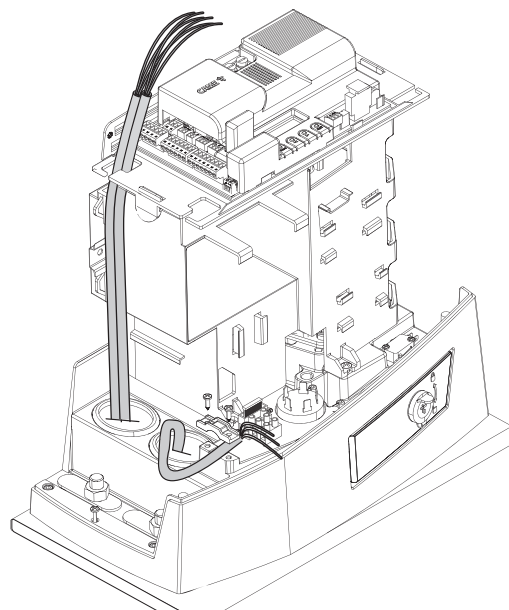
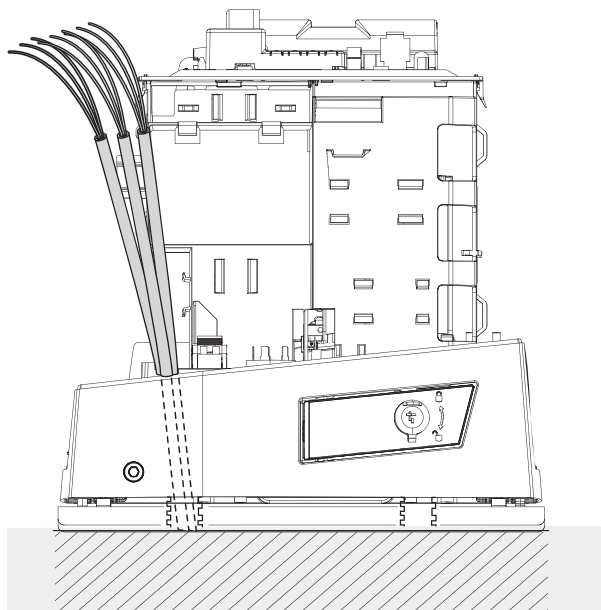

Alimentation

S'assurer, durant toutes les phases d'installation, que l'automatisme est bien hors tension.

⚠ Avant d'intervenir sur l'armoire de commande, mettre hors tension et déconnecter les éventuelles batteries.

Branchement au secteur (120/230 VAC - 50/60 Hz)

- Ⓛ Câble de phase
- Ⓝ Câble neutre
- Ⓧ Câble de mise à la terre

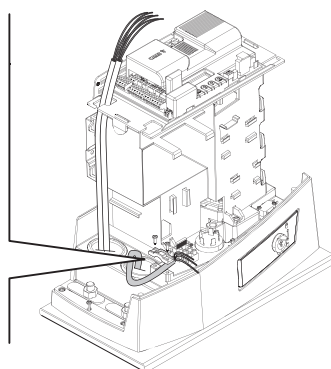
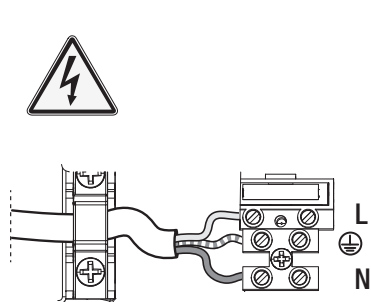

Sortie alimentation pour accessoires

La sortie alimente normalement en 24 VAC.

La somme des absorptions des accessoires connectés ne doit pas dépasser 20 W.

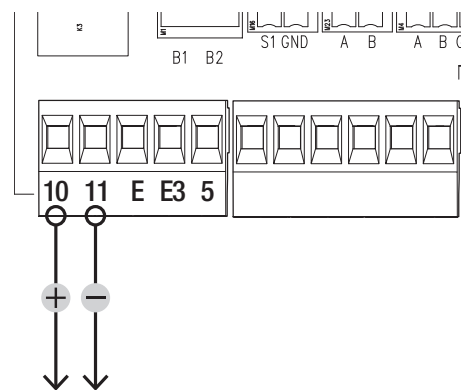

Portée maximum des contacts

Dispositif	Sortie	Alimentation (V)	Puissance (W)
Accessoires	10 - 11	24 AC/DC	20
Lampe supplémentaire	10 - E3	24 AC/DC	12
Feu clignotant	10 - E	24 AC/DC	3
Témoin état automatisme	10 - 5	24 AC/DC	3

Enlever le couvercle de protection de la carte électronique.

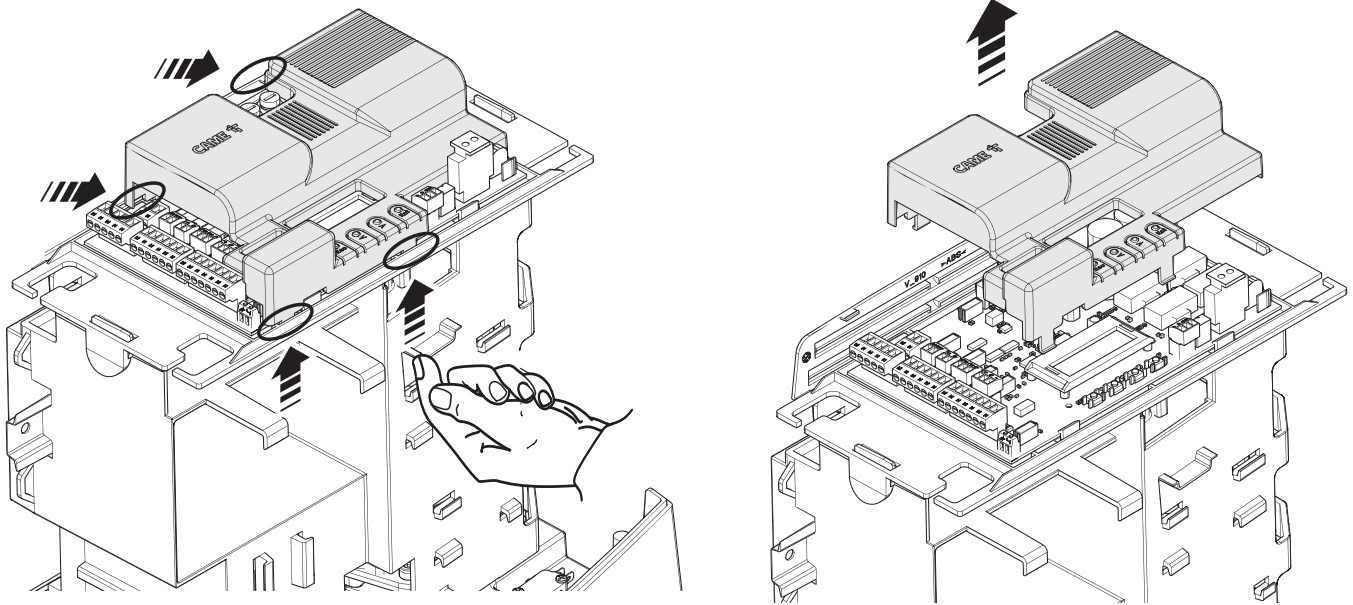

Dispositifs de signalisation

1 Feu clignotant

Clignote durant les phases d'ouverture et de fermeture de l'automatisme.

2 Lampe supplémentaire

Permet d'augmenter l'éclairage de la zone de manœuvre.

3 Témoin état automatisme

Signale l'état de l'automatisme.

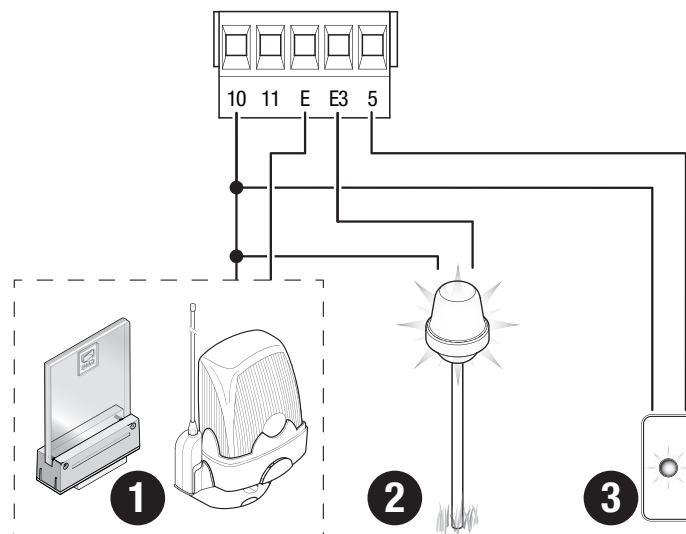

Dispositifs de commande

- 1 Lecteur pour cartes
- 2 Sélecteur transpondeur
- 3 Clavier à code
- 4 Bouton d'ARRÊT (contact NF)

Arrête le portail et désactive l'éventuelle fermeture automatique. Utiliser un dispositif de commande pour reprendre le mouvement.

 Si le contact n'est pas utilisé, il doit être désactivé pendant la programmation.

- 5 Dispositif de commande (contact NO)

Fonction OUVERTURE SEULEMENT

- 6 Dispositif de commande (contact NO)

Fonction OUVERTURE PARTIELLE

- 7 Dispositif de commande (contact NO)

Fonction FERMETURE SEULEMENT

- 8 Dispositif de commande (contact NO)

Fonction OUVERTURE-FERMETURE (pas-à-pas) ou OUVERTURE-ARRÊT-FERMETURE-ARRÊT (séquentielle)

- 9 Antenne avec câble RG58

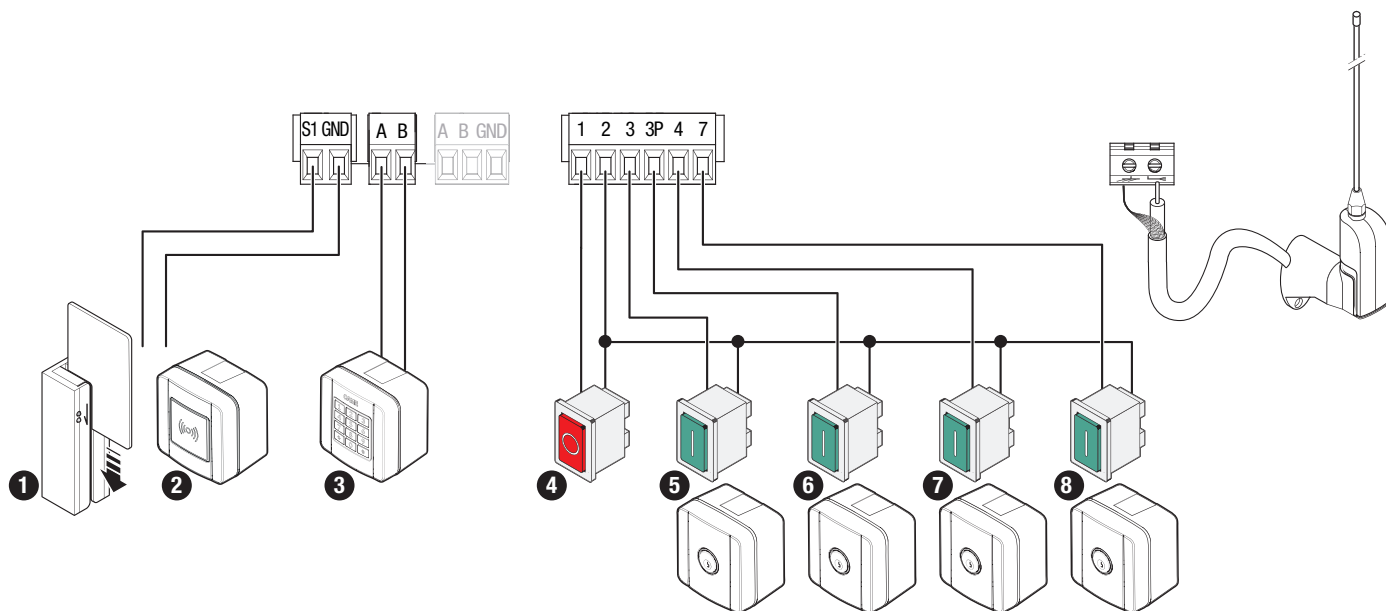

Dispositifs de sécurité

Connecter les dispositifs de sécurité aux entrées CX, CY, CZ et/ou CK (contacts NF).

Pendant la programmation, configurer le type d'action que le dispositif connecté à l'entrée doit effectuer.

📖 En cas de non utilisation des contacts CX, CY, CZ et/ou CK, les désactiver en phase de programmation.

Photocellules DELTA

Connexion standard

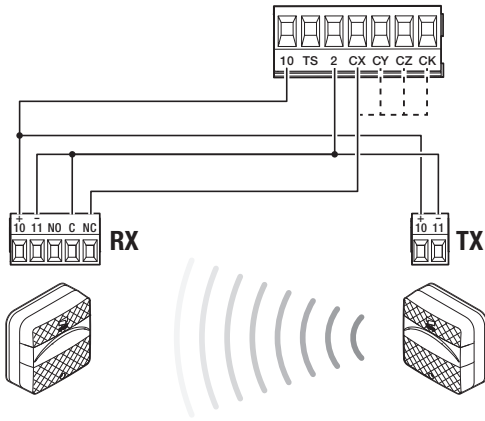

Photocellules DELTA

Connexion avec test de sécurité

📖 Voir fonction F5 test dispositifs de sécurité.

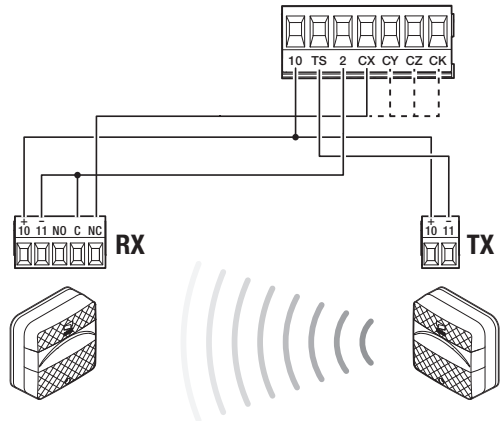

Photocellules DIR / DELTA-S

Connexion standard

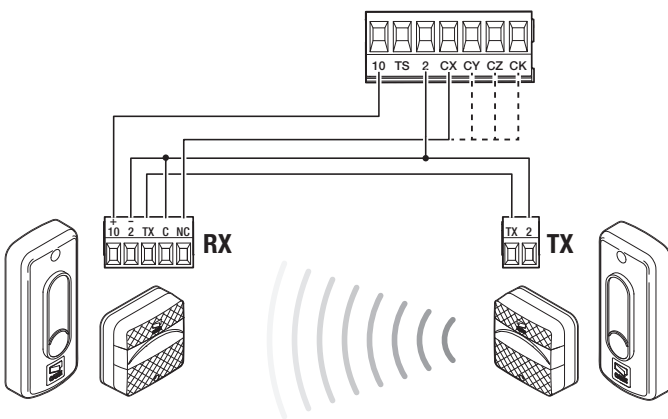

Photocellules DIR / DELTA-S

Connexion avec test de sécurité

📖 Voir fonction F5 test dispositifs de sécurité.

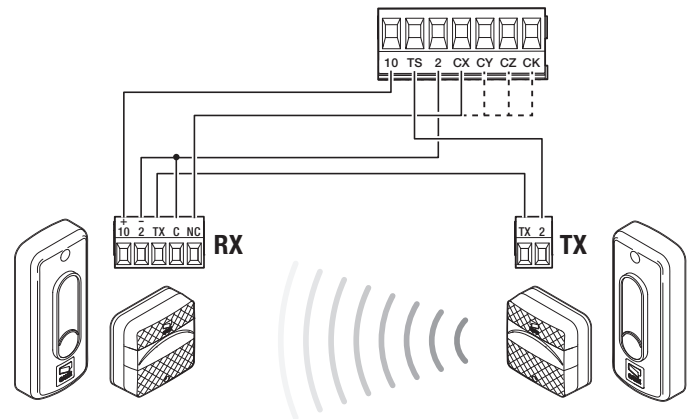

Bord sensible DFWN

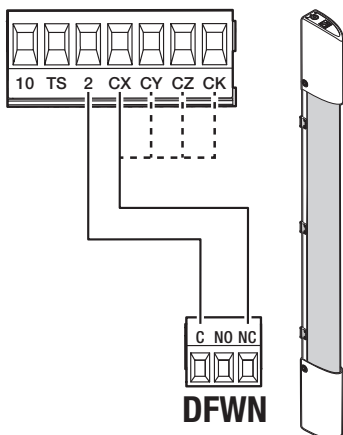

Paire de bords sensibles DFWN

Connexion en parallèle (conseillé)

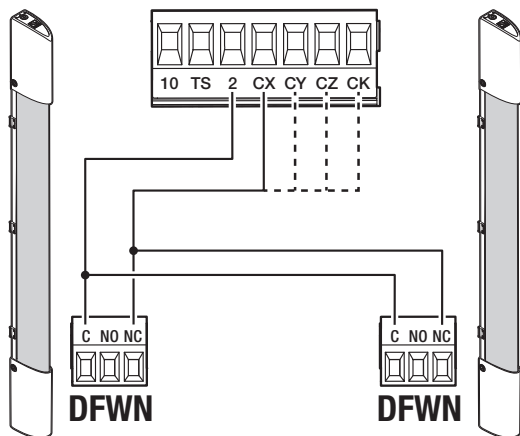

Paire de bords sensibles DFWN

Connexion en série

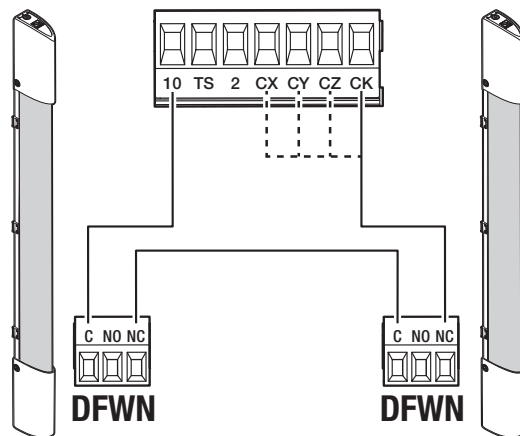

Fonction des touches de programmation

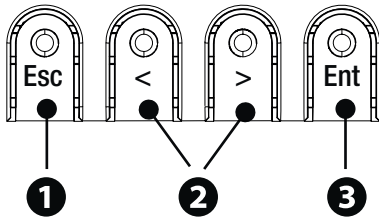

1 Touche ESC

La touche ESC permet d'effectuer les opérations décrites ci-après.
 Sortir du menu
 Annuler les modifications
 Revenir à la page-écran précédente
 Arrêter l'automatisme

2 Touches < >

Les touches < > permettent d'effectuer les opérations décrites ci-après.
 Naviguer dans les options du menu
 Augmenter ou diminuer une valeur
 Fermer ou ouvrir l'automatisme

3 Touche ENTER

La touche ENTER permet d'effectuer les opérations décrites ci-après.
 Entrer dans les menus
 Confirmer le choix

Mise en fonction

- Au terme des branchements électriques, effectuer la mise en marche. L'opération ne doit être effectuée que par du personnel qualifié et spécialisé. S'assurer que la zone de manœuvre ne présente aucun obstacle. Mettre sous tension et suivre la procédure guidée visualisée à l'écran.
- Après avoir mis l'installation sous tension, la première manœuvre a toujours lieu en ouverture; attendre l'exécution complète de la manœuvre.
- Appuyer immédiatement sur le bouton d'arrêt (STOP) en cas d'anomalies, mauvais fonctionnements, bruit, vibrations suspectes ou comportements imprévus de l'installation.

Menu des fonctions

Sens d'ouverture

Configure le sens d'ouverture du portail.

Configuration Configurations moteur	Sens d'ouverture	Vers la gauche (par défaut) Vers la droite
--	------------------	---

Essai moteur

Contrôle du bon sens d'ouverture du portail.

- Si les touches n'exécutent pas correctement les commandes, inverser le sens d'ouverture du portail.

Configuration Configurations moteur	Essai moteur	La touche > permet de fermer le portail La touche < permet d'ouvrir le portail
--	--------------	---

Auto-apprentissage de la course

Permet de lancer l'auto-apprentissage de la course.

Configuration Configurations moteur	Auto-apprentissage de la course	Confirmer ? NON Confirmer ? OUI
--	---------------------------------	------------------------------------

Type moteur

Configure le type de motoréducteur installé.

Configuration Configurations moteur	Type moteur	BKV1500 BKV2000 BKV2500
--	-------------	-------------------------------

Vitesse ouverture

Configure la vitesse d'ouverture (pourcentage de la vitesse maximale).

Configuration Configurations de la course	Vitesse ouverture	de 40 % à 100 % (par défaut 100 %)
--	--------------------------	------------------------------------

Vitesse fermeture

Configure la vitesse de fermeture (pourcentage de la vitesse maximale).

Configuration Configurations de la course	Vitesse fermeture	de 40 % à 100 % (par défaut 100 %)
--	--------------------------	------------------------------------

Vitesse de ralentissement en ouverture

Configure la vitesse de ralentissement en phase d'ouverture (pourcentage de la vitesse maximale).

Configuration Configurations de la course	Vitesse ral. ouverture	de 15 % à 60 % (50 % par défaut)
--	-------------------------------	----------------------------------

Vitesse de ralentissement en fermeture

Configure la vitesse de ralentissement en phase de fermeture (pourcentage de la vitesse maximale).

Configuration Configurations de la course	Vitesse ral. fermeture	de 15 % à 60 % (50 % par défaut)
--	-------------------------------	----------------------------------

Sensibilité durant la course

Réglage de la sensibilité de détection des obstacles durant la course.

Configuration Configurations de la course	AST control course	Désactivé (par défaut) Minimum Moyen Maximum Personnalisé
--	---------------------------	---

Sensibilité ralentissement

Pour le réglage de la sensibilité de détection des obstacles durant la phase de ralentissement.

Configuration Configurations de la course	AST control au ral	Désactivé (par défaut) Minimum Moyen Maximum Personnalisé
--	---------------------------	---

Départ ralenti

Pour configurer un ralentissement de quelques secondes après chaque commande d'ouverture et de fermeture.

Configuration Configurations de la course	Départ ralenti	Désactivé (par défaut) Activé
--	-----------------------	----------------------------------

Point d'ouverture partielle

Détermine, en pourcentage sur la course totale, le point d'ouverture partielle du portail.

Configuration Configurations de la course	Point ouv. partielle	de 10 % à 100 % (20 % par défaut)
--	-----------------------------	-----------------------------------

Point de ralentissement en ouverture

Pour le réglage du point de ralentissement initial à l'ouverture (pourcentage de la course totale).

Configuration Configurations de la course	Point ral. ouverture	De 10 % à 60 % (25 % par défaut)
--	----------------------	----------------------------------

Point de ralentissement en fermeture

Pour le réglage du point de ralentissement initial à la fermeture (pourcentage de la course totale).

Configuration Configurations de la course	Point ral. fermeture	De 10 % à 60 % (25 % par défaut)
--	----------------------	----------------------------------

Arrêt Total

Arrête le portail et désactive l'éventuelle fermeture automatique. Utiliser un dispositif de commande pour reprendre le mouvement.

Configuration Sécurités filaires	Arrêt Total	Désactivé (par défaut) Activé
-------------------------------------	-------------	----------------------------------

Entrée CX

Associe une fonction à l'entrée CX

Configuration Sécurités filaires	Entrée CX	Désactivé (par défaut) C1 = Réouverture durant la fermeture (Photocellules) C2 = Refermeture durant l'ouverture (Photocellules) C3 = Arrêt partiel C4 = Attente obstacle (Photocellules) C7 = Réouverture durant la fermeture (Bords sensibles) C8 = Refermeture durant l'ouverture (Bords sensibles) C13 = Réouverture durant la fermeture avec fermeture immédiate après l'élimination de l'obstacle, y compris avec portail à l'arrêt r7 = Réouverture durant la fermeture (Bords sensibles avec résistance 8K2) r8 = Refermeture durant l'ouverture (Bords sensibles avec résistance 8K2) r7 (deux bords sensibles) = réouverture durant la fermeture (Paire de bords sensibles avec résistance 8K2) r8 (deux bords sensibles) = refermeture durant l'ouverture (Paire de bords sensibles avec résistance 8K2)
-------------------------------------	-----------	---

Entrée CY

Associe une fonction à l'entrée CY

Configuration Sécurités filaires	Entrée CY	Désactivé (par défaut) C1 = Réouverture durant la fermeture (Photocellules) C2 = Refermeture durant l'ouverture (Photocellules) C3 = Arrêt partiel C4 = Attente obstacle (Photocellules) C7 = Réouverture durant la fermeture (Bords sensibles) C8 = Refermeture durant l'ouverture (Bords sensibles) C13 = Réouverture durant la fermeture avec fermeture immédiate après l'élimination de l'obstacle, y compris avec portail à l'arrêt r7 = Réouverture durant la fermeture (Bords sensibles avec résistance 8K2) r8 = Refermeture durant l'ouverture (Bords sensibles avec résistance 8K2) r7 (deux bords sensibles) = réouverture durant la fermeture (Paire de bords sensibles avec résistance 8K2) r8 (deux bords sensibles) = refermeture durant l'ouverture (Paire de bords sensibles avec résistance 8K2)
-------------------------------------	-----------	---

Entrée CZ

Associe une fonction à l'entrée CZ

Configuration Sécurités filaires	Entrée CZ	Désactivé (par défaut) C1 = Réouverture durant la fermeture (Photocellules) C2 = Refermeture durant l'ouverture (Photocellules) C3 = Arrêt partiel C4 = Attente obstacle (Photocellules) C7 = Réouverture durant la fermeture (Bords sensibles) C8 = Refermeture durant l'ouverture (Bords sensibles) C13 = Réouverture durant la fermeture avec fermeture immédiate après l'élimination de l'obstacle, y compris avec portail à l'arrêt r7 = Réouverture durant la fermeture (Bords sensibles avec résistance 8K2) r8 = Refermeture durant l'ouverture (Bords sensibles avec résistance 8K2) r7 (deux bords sensibles) = réouverture durant la fermeture (Paire de bords sensibles avec résistance 8K2) r8 (deux bords sensibles) = refermeture durant l'ouverture (Paire de bords sensibles avec résistance 8K2)
--	------------------	---

Entrée CK

Associe une fonction à l'entrée CK

Configuration Sécurités filaires	Entrée CK	Désactivé (par défaut) C1 = Réouverture durant la fermeture (Photocellules) C2 = Refermeture durant l'ouverture (Photocellules) C3 = Arrêt partiel C4 = Attente obstacle (Photocellules) C7 = Réouverture durant la fermeture (Bords sensibles) C8 = Refermeture durant l'ouverture (Bords sensibles) C13 = Réouverture durant la fermeture avec fermeture immédiate après l'élimination de l'obstacle, y compris avec portail à l'arrêt r7 = Réouverture durant la fermeture (Bords sensibles avec résistance 8K2) r8 = Refermeture durant l'ouverture (Bords sensibles avec résistance 8K2) r7 (deux bords sensibles) = réouverture durant la fermeture (Paire de bords sensibles avec résistance 8K2) r8 (deux bords sensibles) = refermeture durant l'ouverture (Paire de bords sensibles avec résistance 8K2)
--	------------------	---

Test sécurité

Active le contrôle du bon fonctionnement des photocellules connectées aux entrées, après chaque commande d'ouverture et de fermeture.

Configuration Sécurités filaires	Test sécurité	Désactivé (par défaut) Activé
--	----------------------	----------------------------------

Obstacle avec moteur arrêté

Lorsque la fonction est activée, le portail reste immobile si les dispositifs de sécurité détectent un obstacle. La fonction est activée avec : portail fermé, portail ouvert ou après un arrêt total.

Configuration Sécurités filaires	Obst. avec moteur arrêté	Désactivé (par défaut) Activé
--	---------------------------------	----------------------------------

RIO ED T1

Permet d'associer une fonction parmi celles prévues à un dispositif de sécurité sans fil.

La fonction n'apparaît que s'il existe une carte d'interface pour les dispositifs sans fil.

Configuration Sécurités RIO	RIO ED T1	Désactivé (par défaut) P0 = Arrête le portail et désactive l'éventuelle fermeture automatique. Utiliser un dispositif de commande pour reprendre le mouvement. P7 = Réouverture durant la fermeture. P8 = Refermeture durant l'ouverture.
---------------------------------------	------------------	--

RIO ED T2

Permet d'associer une fonction parmi celles prévues à un dispositif de sécurité sans fil.

La fonction n'apparaît que s'il existe une carte d'interface pour les dispositifs sans fil.

Configuration Sécurités RIO	RIO ED T2	Désactivé (par défaut) P0 = Arrête le portail et désactive l'éventuelle fermeture automatique. Utiliser un dispositif de commande pour reprendre le mouvement. P7 = Réouverture durant la fermeture. P8 = Refermeture durant l'ouverture.
--------------------------------	-----------	--

RIO PH T1

Permet d'associer une fonction parmi celles prévues à un dispositif de sécurité sans fil.

La fonction n'apparaît que s'il existe une carte d'interface pour les dispositifs sans fil.

Configuration Sécurités RIO	RIO PH T1	Désactivé (par défaut) P1 = Réouverture durant la fermeture. P2 = Refermeture durant l'ouverture. P3 = Arrêt partiel. P4 = Attente obstacle. P13 = Réouverture durant la fermeture avec fermeture immédiate après l'élimination de l'obstacle, y compris avec portail à l'arrêt.
--------------------------------	-----------	---

RIO PH T2

Permet d'associer une fonction parmi celles prévues à un dispositif de sécurité sans fil.

La fonction n'apparaît que s'il existe une carte d'interface pour les dispositifs sans fil.

Configuration Sécurités RIO	RIO PH T2	Désactivé (par défaut) P1 = Réouverture durant la fermeture. P2 = Refermeture durant l'ouverture. P3 = Arrêt partiel. P4 = Attente obstacle. P13 = Réouverture durant la fermeture avec fermeture immédiate après l'élimination de l'obstacle, y compris avec portail à l'arrêt.
--------------------------------	-----------	---

Commande 2-7

Pour l'association d'une commande au dispositif connecté sur 2-7.

Configuration Entrées commande	Commande 2-7	Pas-à-pas (par défaut) Séquentielle
-----------------------------------	--------------	--

Action maintenue

Avec la fonction activée, le mouvement de l'automatisme (ouverture ou fermeture) est interrompu au relâchement du dispositif de commande.

 L'activation de cette fonction désactive tous les autres dispositifs de commande.

Configuration Fonctions	Action maintenue	Désactivé (par défaut) Activé
----------------------------	------------------	----------------------------------

Sortie B1-B2

Pour la configuration du contact.

Configuration Fonctions	Sortie B1-B2	Bistable (par défaut) Monostable Le contact reste fermé entre 1 et 180 secondes.
----------------------------	--------------	--

Mode sans obstacle

En cas de détection d'un obstacle par le bord sensible ou par le capteur ampérométrique de la carte électronique, il y a inversion du sens de marche de manière à ce que l'espace suffise pour libérer l'obstacle.

Lorsque cette fonction est désactivée, il y a inversion du sens de marche jusqu'à la butée de fin de course.

Configuration Fonctions	Mode sans obstacle	Désactivé (par défaut) Activé
----------------------------	---------------------------	----------------------------------

Fermeture automatique

Configure le temps devant s'écouler avant que la fermeture automatique ne soit activée, une fois que le point de fin de course a été atteint en phase d'ouverture.

 La fonction n'est pas activée lorsque : les dispositifs de sécurité interviennent pour détecter un obstacle, après un arrêt total ou à défaut de tension.

Configuration Temps	Ferm. Automatique	Désactivé (par défaut) De 1 à 180 secondes
------------------------	--------------------------	---

Fermeture automatique après une ouverture partielle

Configure le temps devant s'écouler avant que la fermeture automatique ne soit activée, après exécution d'une commande d'ouverture partielle.

 La fonction n'est pas activée lorsque : les dispositifs de sécurité interviennent pour détecter un obstacle, après un arrêt total ou à défaut de tension.

 Ne pas désactiver la fonction [Ferm. automatique].

Configuration Temps	Ferm. auto. partielle	Désactivé De 1 à 180 secondes (10 secondes par défaut)
------------------------	------------------------------	---



Voyant portail ouvert

Signale l'état du portail.

Configuration Gestion lampes	Voyant portail ouvert	Témoin allumé (par défaut) - Le témoin reste allumé lorsque le portail est en mouvement ou qu'il est ouvert. Témoin clignotant - Le témoin clignote durant le mouvement du portail et reste allumé lorsque ce dernier est ouvert.
---------------------------------	------------------------------	--

Lampe E3

Permet de choisir le mode de fonctionnement de l'appareil d'éclairage connecté à la sortie.

Configuration Gestion lampes	Lampe E3	Désactivé (par défaut) Lampe cycle  La lampe reste éteinte à moins qu'un temps de fermeture automatique ne soit configuré. Lampe d'accueil  La lampe reste allumée pendant le temps configuré par la fonction [Temps accueil].
---------------------------------	-----------------	--

Temps accueil

Configure le temps d'allumage du dispositif d'éclairage.

Configuration Gestion lampes	Temps accueil	de 60 à 180 secondes (60 secondes par défaut)
---------------------------------	----------------------	---

Temps préclignotement

Configure le temps d'activation anticipée du clignotant, avant chaque manœuvre.

Configuration Gestion lampes	Temps préclignotement	Désactivé (par défaut) De 1 à 10 secondes
---------------------------------	------------------------------	--

RSE1

Configure la fonction que la carte enfichée sur le connecteur RSE1 doit effectuer.

 En cas de présence, sur le connecteur RSE_1, d'une carte RSE configurée pour la connexion vis-à-vis, utiliser le connecteur RSE_2 pour la connexion à distance (CRP). Dans ce cas, la possibilité de connecter CAME KEY est exclue.

Configuration Communication RSE	RSE1	CRP (par défaut) Vis-à-vis Désactivé
------------------------------------	------	--

Adresse CRP

Attribue un code d'identification univoque (adresse CRP) à la carte électronique. Cette fonction est nécessaire si plusieurs automatismes sont connectés via CRP.

Configuration Communication RSE	Adresse CRP	de 1 à 254
------------------------------------	-------------	------------

Vitesse RSE1

Configure la vitesse de communication du système de connexion à distance sur le port RSE1.

Configuration Communication RSE	Vitesse RSE1	1200 bps 2400 bps 4800 bps 9600 bps 14400 bps 19200 bps 38400 bps (par défaut) 57600 bps 115200 bps
------------------------------------	--------------	---

Vitesse RSE2

Configure la vitesse de communication du système de connexion à distance sur le port RSE2.

Configuration Communication RSE	Vitesse RSE2	1200 bps 2400 bps 4800 bps 9600 bps 14400 bps 19200 bps 38400 bps (par défaut) 57600 bps 115200 bps
------------------------------------	--------------	---

Sauvegarde des données

Sauvegarde les données des utilisateurs, de synchronisation et de configuration sur le périphérique mémoire (memory roll ou clé USB).

 La fonction n'est visualisée qu'à l'introduction d'une clé dans le port USB ou à l'introduction d'une memory roll dans la carte électronique.

Configuration Mémoire externe	Sauvegarde des données	
----------------------------------	------------------------	--

Lecture données

Télécharge les données des utilisateurs, de synchronisation et de configuration sur le périphérique mémoire (memory roll ou clé USB).

 La fonction n'est visualisée qu'à l'introduction d'une clé dans le port USB ou à l'introduction d'une memory roll dans la carte électronique.

Configuration Mémoire externe	Lecture données	
----------------------------------	-----------------	--

Nouvel Utilisateur

Permet d'enregistrer jusqu'à 250 utilisateurs et d'attribuer une fonction à chacun d'eux.

 Cette opération peut être effectuée par le biais d'un émetteur ou d'un autre dispositif de commande. Les cartes qui gèrent les dispositifs de commande (AF - R700 - R800) doivent être enfichées dans les connecteurs.

Gestion utilisateurs	Nouvel Utilisateur	Pas-à-pas Séquentielle Ouverture Ouverture partielle Sortie B1-B2 Choisir la fonction à attribuer à l'utilisateur. Appuyer sur ENTER pour confirmer. Envoyer le code depuis le dispositif de commande. Répéter la procédure pour ajouter d'autres utilisateurs.
----------------------	--------------------	---

Supprimer utilisateur

Permet d'effacer un des utilisateurs enregistrés.

Gestion utilisateurs	Supprimer utilisateur	Se servir des flèches pour choisir le numéro associé à l'utilisateur à éliminer. Nbre : 1 > 250 Il est également possible d'actionner le dispositif de commande associé à l'utilisateur que l'on souhaite éliminer. Appuyer sur ENTER pour confirmer. L'écran affichera CLR pour confirmer l'élimination. Confirmer ? NON Confirmer ? OUI
----------------------	-----------------------	---

Supprimer tous

Permet d'effacer tous les utilisateurs enregistrés.

Gestion utilisateurs	Supprimer tous	Confirmer ? NON Confirmer ? OUI
----------------------	----------------	------------------------------------

Décodage radio

Permet de choisir le type de codage radio des émetteurs pouvant commander l'automatisme.

 La sélection du type de codage radio des émetteurs [Rolling code] ou [TW key block] effacera tout éventuel émetteur à codage radio différent précédemment mémorisé.

Gestion utilisateurs	Décodage radio	Tous les décodages Rolling code TW Key block Confirmer ? NON Confirmer ? OUI
----------------------	----------------	--

Type de capteur

Configure le type de dispositif de commande.

Gestion utilisateurs	Type de capteur	Clavier Transpondeur
----------------------	-----------------	-------------------------

Changement de modalit 

Modifie la fonction attribu e   un utilisateur bien pr cis.

Gestion utilisateurs	Changement de modalit�	S�lectionner l'utilisateur dont on souhaite modifier la commande.  Il est possible de s�lectionner l'utilisateur sans utiliser les fl�ches, en envoyant une commande depuis le dispositif associ� � l'utilisateur. Appuyer sur ENTER pour confirmer. Choisir la commande � associer � l'utilisateur. Appuyer sur ENTER pour confirmer. Confirmer ? NON Confirmer ? OUI
----------------------	-------------------------------	---

Version FW

Permet de visualiser le num ro de la version firmware et GUI install es.

Informations	Version FW	FW x.x.xx (firmware) GUI x.x (graphique)
--------------	-------------------	---

Comptage man uvres

Permet de visualiser le nombre de man uvres effectu es par l'automatisme.

Man uvres totales = Man uvres effectu e   compter de l'installation.

Man uvres partielles = Man uvres effectu es apr s la derni re [R initialisation param tres].

Informations	Comptage man�uvres	Man�uvres totales Man�uvres partielles
--------------	---------------------------	---

Configuration entretien

Permet de d finir le nombre de man uvres que l'automatisme peut effectuer, avant qu'un signal ne soit g n r  pour signaler la n cessit  d'effectuer la maintenance. Le signal consiste en un clignotement rythmique 3 + 3 fois par heure du t moin [Ouverture].

Informations	Configuration entretien	D�sactiv� (par d�faut) de 1X100 � 250X100
--------------	--------------------------------	--

R Z entretien

Remet   z ro le calcul du nombre des man uvres partielles.

Informations	R�Z entretien	Confirmer ? NON Confirmer ? OUI
--------------	----------------------	------------------------------------

R Z param tres

Restaure les configurations d'usine   l'exception des fonctions suivantes : [D codage radio], [Type moteur] et les configurations pour l'auto-apprentissage de la course.

Informations	R�Z param�tres	Confirmer ? NON Confirmer ? OUI
--------------	-----------------------	------------------------------------

Liste erreurs

Permet de visualiser les 8 derni res erreurs d tect es. La liste erreurs peut  tre  limin e.

Informations	Liste erreurs	Se servir des fl�ches pour faire d�filer la liste. Pour effacer la liste des erreurs, s�lectionner [Effacer erreurs] Appuyer sur ENTER pour confirmer. Confirmer ? NON Confirmer ? OUI
--------------	----------------------	--

Visualiser horloge

Permet d'activer la visualisation de l'horloge sur l'afficheur.

Gestion minuterie	Visualiser horloge	
-------------------	---------------------------	--

Configurer horloge

Permet de configurer la date et l'heure.

Gestion minuterie	Configurer horloge	Se servir des flèches et du bouton Enter pour ajouter les valeurs souhaitées.
-------------------	---------------------------	---

DST automatique

Permet d'activer la configuration automatique de l'heure d'été.

Gestion minuterie	DST automatique	Désactivé (par défaut) Activé
-------------------	------------------------	----------------------------------

Format heure

Permet de choisir le format de visualisation de l'horloge.

Gestion minuterie	Format heure	24 heures 12 heures (AM/PM)
-------------------	---------------------	--------------------------------

Créer nouvelle minuterie

Permet de temporiser un ou deux types d'activations au choix parmi ceux disponibles.

Gestion minuterie	Créer nouvelle minuterie	Se servir des flèches pour choisir la fonction souhaitée. Ouverture / Ouverture partielle / Sortie B1-B2 Appuyer sur ENTER pour confirmer. Se servir des flèches pour configurer l'heure de début et l'heure de fin de l'activation de la fonction. Horaire début / Horaire fin Appuyer sur ENTER pour confirmer. Se servir des flèches pour configurer les jours d'activation de la fonction Sélectionner jours / Toute semaine Appuyer sur ENTER pour confirmer.
-------------------	---------------------------------	--

Éliminer minuterie

Permet d'effacer une des temporisations sauvegardées.

Gestion minuterie	Éliminer minuterie	Se servir des flèches pour choisir la temporisation à éliminer. O = [Ouverture] P = [Ouverture partielle] B = [Sortie B1-B2] Appuyer sur ENTER pour confirmer.
-------------------	---------------------------	--

Commandes

Permet de faire exécuter certaines commandes au portail sans l'aide de dispositifs de commande.

Commandes		Ouverture Ouverture partielle Fermeture Arrêt Se servir des flèches pour sélectionner la commande à exécuter. Appuyer sur ENTER pour confirmer.
------------------	--	--

Langue

Configure la langue de l'afficheur.

Langue		Italiano (IT) English (EN) Français (FR) Deutsch (DE) Español (ES) Português (PT) Polski (PL) Русский (RU)
--------	--	---

Permet d'activer le mot de passe

Permet de configurer un mot de passe de 4 chiffres. Le mot de passe sera demandé à quiconque souhaite accéder au menu principal.

Mot de passe	Permet d'activer le mot de passe	Se servir des flèches et du bouton Enter pour composer le code souhaité. Répéter le mot de passe à l'aide des flèches et du bouton Enter pour valider.
--------------	----------------------------------	---

Mot de passe perdu

En cas de perte du mot de passe, exécuter les opérations décrites ci-après.

Mettre la carte électronique hors tension.

Appuyer sur les touches < > et les maintenir enfoncées puis remettre la carte électronique sous tension.

Maintenir les touches < > enfoncées jusqu'à ce que l'écran affiche [RàZ par défaut].

Sélectionner [Confirmer ? OUI].

Appuyer sur ENTER pour confirmer.

 La procédure de réinitialisation de la carte électronique supprime tous les utilisateurs enregistrés, les temporisations configurées et les données d'étalonnage.

Éliminer mot de passe

Permet d'éliminer le mot de passe de protection de l'accès au menu principal.

Mot de passe	Éliminer mot de passe	Confirmer ? NON Confirmer ? OUI
--------------	-----------------------	------------------------------------

Modifier mot de passe

Permet de changer le mot de passe de 4 chiffres de protection de l'accès au menu principal.

Mot de passe	Modifier mot de passe	Se servir des flèches et du bouton Enter pour composer le code souhaité. Répéter le mot de passe à l'aide des flèches et du bouton Enter pour valider.
--------------	-----------------------	---

Menu F

Permet d'activer la visualisation du menu fonctions F.

MESSAGES D'ERREUR

Erreur de calibrage	Interruption de l'auto-apprentissage de la course due à la présence d'un obstacle.
Encodeur en panne	L'encodeur est déconnecté. L'encodeur est cassé.
Erreur test services échoué	Présence d'un obstacle dans le rayon d'action des photocellules. Les photocellules ne sont pas connectées ou configurées correctement. Les photocellules sont cassées.
Porte ouverte	L'automatisme est débloqué.
Nbre maximum obstacles en fermeture	Dépassement du nombre maximum d'obstacles détectés consécutivement
Nbre maximum obstacles en ouverture	Dépassement du nombre maximum d'obstacles détectés consécutivement
Erreur maximum obstacles	Dépassement du nombre maximum d'obstacles détectés consécutivement
Erreur communication	La configuration sur le port RSE est incorrecte.
Radiocommande incompatible	L'émetteur utilisé n'est pas un émetteur CAME. Le décodage configuré diffère de celui de l'émetteur. Les émetteurs sont des émetteurs TWIN et possèdent des KEY BLOCK différentes.
Porte SLAVE ouverte	L'automatisme SLAVE est débloqué.
Le système RIO ne communique pas	Le module sans fil n'est pas enfiché sur le connecteur de la carte électronique. Le module sans fil est cassé.
Système RIO pas configuré	Le module sans fil n'a pas été configuré. Les dispositifs sans fil n'ont pas été configurés.

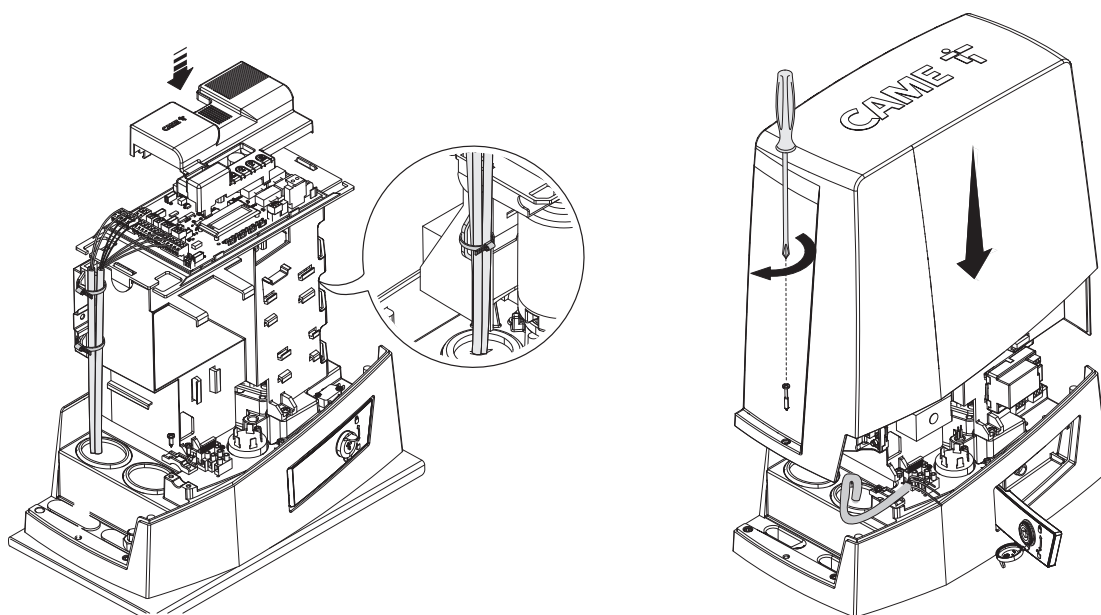

FONCTIONNEMENT VIS-À-VIS

Commande unique de deux automatismes connectés.

Branchements électriques

Connecter les deux cartes électroniques avec un câble UTP CAT 5.

Insérer une carte RSE sur les deux cartes électroniques en utilisant le connecteur RSE_1.

Effectuer le branchement électrique des dispositifs et des accessoires.

Les dispositifs et les accessoires doivent être connectés sur la carte électronique qui sera configurée comme MASTER.

Pour les branchements électriques des dispositifs et des accessoires, voir le chapitre BRANCHEMENTS ÉLECTRIQUES.

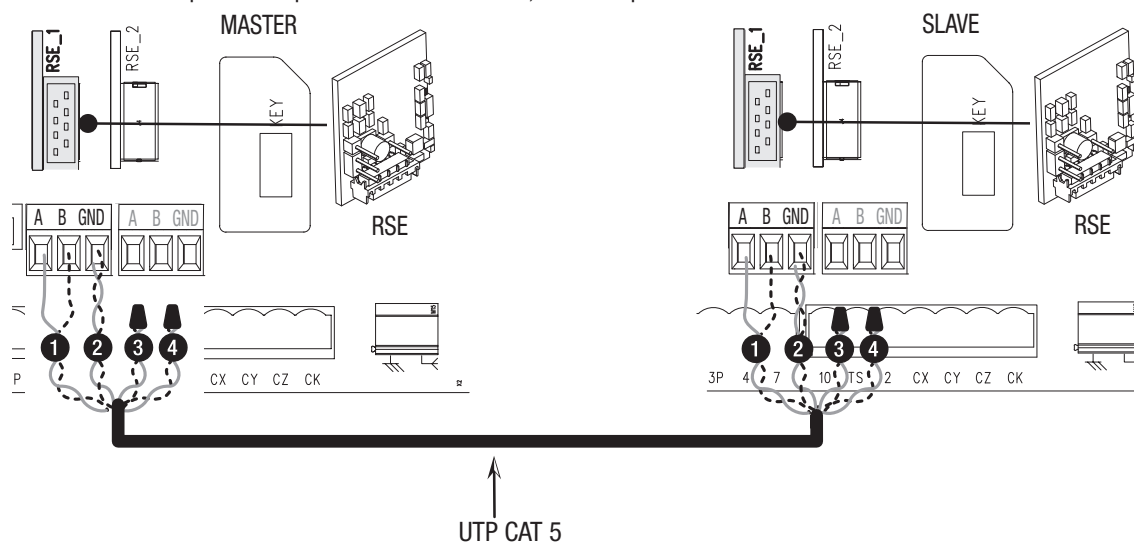

Programmation

Toutes les opérations de programmation décrites ci-après ne doivent être effectuées que sur la carte électronique configurée comme MASTER. Sélectionner le type d'installation [Vis-à-vis] durant la procédure guidée ou bien configurer le port RSE_1 dans [Vis-à-vis].

Après la programmation de l'automatisme MASTER en [Vis-à-vis], le deuxième automatisme devient automatiquement SLAVE.

Mémorisation des utilisateurs

Toutes les opérations de mémorisation des utilisateurs ne doivent être effectuées que sur la carte électronique configurée comme MASTER.

Modalité de fonctionnement

- 1 Commande OUVERTURE PARTIELLE
- 2 Commande PAS-À-PAS ou OUVERTURE UNIQUEMENT

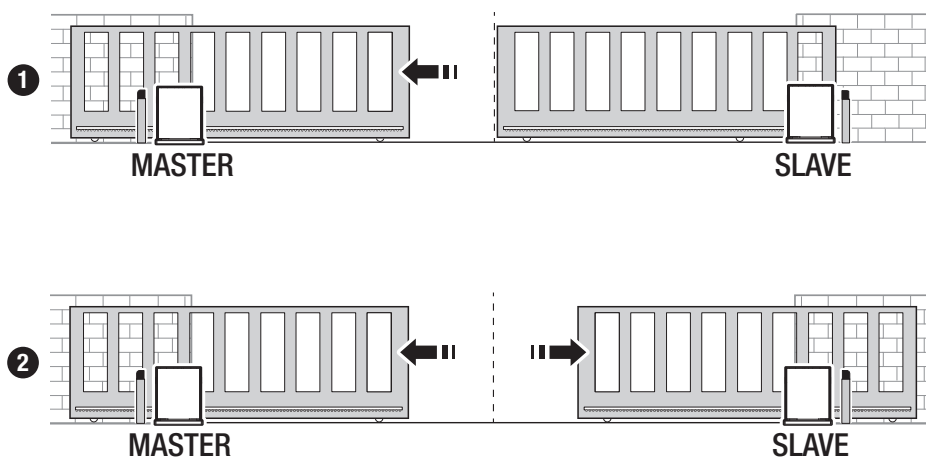

MCBF			
Modèles	BKV15	BKV20	BKV25
20 m - 1500 kg	250000	-	-
20 m - 2000 kg	-	250000	-
20 m - 2500 kg	-	-	250000
Installation dans une zone exposée au vent	-15%	-15%	-15%

 Les pourcentages indiquent dans quelle mesure il faut réduire le nombre de cycles par rapport au type et au nombre d'accessoires installés.

 Avant toute opération de nettoyage, d'entretien ou de remplacement de pièces détachées, mettre le dispositif hors tension.

 Ce document fournit à l'installateur les indications sur les contrôles obligatoires à effectuer durant les interventions de maintenance.

 Si le système n'est pas utilisé pendant de longues périodes, par exemple dans le cas d'installations dans des endroits à ouverture saisonnière, il est recommandé de couper l'alimentation électrique et de vérifier, à la remise sous tension, qu'il fonctionne correctement.

 Pour plus d'informations sur l'installation et les réglages appropriés, consulter le manuel d'installation du produit.

 Pour toutes les informations concernant le choix du produit et de ses accessoires, consulter le catalogue des produits.

 Tous les 10 000 cycles et tous les 6 mois d'activité, les opérations de maintenance suivantes sont obligatoires.

Effectuer un contrôle général et complet du serrage des boulons.

Lubrifier toutes les parties mécaniques en mouvement.

Contrôler le bon fonctionnement des dispositifs de signalisation et de sécurité.

Contrôler l'état d'usure des parties mécaniques en mouvement et en vérifier le bon fonctionnement.

Contrôler le bon fonctionnement du dispositif de déblocage en effectuant une manœuvre avec vantail libre. Le vantail ne doit rencontrer aucun obstacle.

S'assurer que les câbles et leurs connexions sont en bon état.

Contrôler et nettoyer le rail de guidage et la crémaillère.

Fabbricante / Manufacturer / Hersteller / Fabricant / Fabricante / Fabricante
/ Wytwórca / Fabrikant

Came S.p.a.

indirizzo / address / adresse / adresse / direccìon / endereço / adres / adres
Via Martiri della Libertà 15 - 31030 Dosson di Casier, Treviso - Italy



DICHIARA CHE LE AUTOMAZIONI PER CANCELLI SCORREVOLI / DECLARES THAT THE DRIVES FOR SLIDING GATES /
ERKLÄRT DASS DIE AUTOMATISIERUNGEN FÜR SCHIEBETÖRE / DECLARE QUE LES AUTOMATISATIONS POUR
PORTAILS COULISSANTS / DECLARA QUE LAS AUTOMATIZACIONES PARA PUERTAS CORREDERAS / DECLARA QUE AS
AUTOMATIZAÇÕES PARA PORTÕES DE CORRER / OSWADCZA ZE AUTOMATYKA DO BRAM PRZESUWNYCH /
VERKLAART DAT DE AUTOMATISERING VOOR SCHUIFHEKKEN

BKV15AGS ; BKV20AGS ; BKV25AGS
BKV15ALS ; BKV20ALS ; BKV25ALS
BKV15RGS ; BKV20RGS ; BKV15AGE
BKV20AGE ; BKV25AGE

SONO CONFORMI ALLE DISPOSIZIONI DELLE SEGUENTI DIRETTIVE / THEY COMPLY WITH THE PROVISIONS OF THE FOLLOW-
ING DIRECTIVES / DEN VORGABEN DER FOLGENDEN RICHTLINIEN ENTSPRECHEN / SONT CONFORMES AUX DISPOSITIONS
DES DIRECTIVES SUIVANTES / CUMPLEN CON LAS DISPOSICIONES DE LAS SIGUIENTES DIRECTIVAS / ESTÃO DE ACORDO
COM AS DISPOSIÇÕES DAS SEQUENTES DIRECTIVAS / SA ZGODNE Z POSTANOWIENIAMI NASTĘPUJĄCYCH DYREKTYW
EUROPEJSKICH / VOLDOEN AAN DE VOORSCHRIFTEN VAN DE VOLGENDE RICHTLIJNEN:

- COMPATIBILITÀ ELETTRROMAGNETICA / ELECTROMAGNETIC COMPATIBILITY / ELEKTROMAGNETISCHE
VERTRÄGLICHKEIT / COMPATIBILITÉ ÉLECTROMAGNETIQUE / COMPATIBILIDAD ELECTROMAGNETICA / COMPATIBIL-
DADE ELETROMAGNETICA / KOMPATYBILNOŚCI ELEKTROMAGNETYCZNEJ / ELEKTROMAGNETISCHE COMPATIBI-
LITEIT : 2014/30/UE.

Riferimento norme armonizzate ed altre norme tecniche / Refer to
European regulations and other technical regulations / Harmonisierte
Bezugsnormen und andere technische Vorgaben / Référence aux normes
harmonisées et aux autres normes techniques / Referencia normas
armonizadas y otras normas técnicas / Referência de normas harmoniza-
das e outras normas técnicas / Odnosne normy ujednolicono i inne normy
techniczne / Geharmoniseerde en andere technische normen waarnaar is
verwezen

EN 61000-6-2:2005
EN 61000-6-3:2007+A1:2011
EN 62233:2008
EN 60335-1:2012+A11:2014
EN 60335-2-103:2015

RISPETTANO I REQUISITI ESSENZIALI APPLICATI / MEET THE APPLICABLE ESSENTIAL REQUIREMENTS / DEN WESENTLIJHEN
ANGEWANDTEN ANFORDERUNGEN ENTSPRECHEN / RESPECTENT LES CONDITIONS REQUISES NECESSAIRES APPLIQUEES /
/ CUMPLEN CON LOS REQUISITOS ESSENCIALES APLICADOS / RESPETAM O REQUISITOS ESSENCIAIS APLICADOS /
SPEŁNIJĄ PODSTAWOWE WYMAGANIA WYRUNKI / VOLDOEN AAN DE TOEPASBARE MINIMUM EISEN:

1.1.3; 1.1.5; 1.2.1; 1.2.2; 1.3.2; 1.3.7; 1.3.8.1; 1.4.1; 1.4.2; 1.5.1; 1.5.6; 1.5.8; 1.5.9; 1.5.9; 1.5.13; 1.6.1; 1.6.3; 1.6.4;
1.7.1; 1.7.2; 1.7.4

PERSONA AUTORIZZATA A COSTITUIRE LA DOCUMENTAZIONE TECNICA PERTINENTE / PERSON AUTHORISED TO COMPILE THE RELEVANT TECHNICAL DOCUMENTATION /
PERSON DIE BEVOLLMÄCHTIGT IST, DIE RELEVANTEN TECHNISCHEN UNTERLAGEN ZUSAMMENZUSTELLEN / DOCUMENTATION TECHNIQUE SPECIFIQUE D'AUTORISATION
A CONSTRUIRE DE / PERSONA FACULTADA PARA ELABORAR LA DOCUMENTACIÓN TÉCNICA PERTINENTE / PESSOA AUTORIZADA A CONSTITUIR A DOCUMENTAÇÃO TÉCNICA
PERTINENTE / OSOBA UPOWAZNIONA DO ZREDAGOWANIA DOKUMENTACJI TECHNICZNEJ / DIEGENE DIE GEMACHTIGT IS DE RELEVANTE TECHNISCHE DOCUMENTEN
SAMEN TE STELLEN.

CAME S.p.a.

La documentazione tecnica pertinente è stata compilata in conformità all'allegato VIB. / The pertinent technical documentation has been drawn up in compliance with attached
document VIB. / Die relevante technische Dokumentation wurde entsprechend der Anlage VIB ausgestellt. / La documentation technique spécifique a été remplie conformément à
l'annexe VIB. / La documentación técnica pertinente ha sido rellenada en cumplimiento con el anexo VIB. / A documentação técnica pertinente foi preenchida de acordo com o anexo
VIB. / Odnosna dokumentacja techniczna została zredagowana zgodnie z załącznikiem VIB. / De technische documentatie terzake is opgesteld in overeenstemming met de bijlage VIB.

CAME S.p.a. si impegna a trasmettere, in risposta a una richiesta adeguatamente motivata delle autorità nazionali, informazioni pertinenti sulle quasi macchine, e / Came S.p.a., following
a duly motivated request from the national authorities, undertakes to provide information related to the quasi machines, and / Die Firma Came S.p.a. verpflichtet sich auf eine angemessen
motiviert Anfrage der staatlichen Behörden Informationen über die unvollständigen Maschinen, zu übermitteln, und / Came S.p.a. s'engage à transmettre, en réponse à une demande
bien fondée de la part des autorités nationales, les renseignements relatifs aux quasi machines. / Came S.p.a. se compromete a transmitir, como resposta a una solicitud adecuadamente
fundada por parte de las autoridades nacionales, informaciones relacionadas con las cuasimáquinas. / Came S.p.a. compromete-se em transmitir, em resposta a uma solicitação motivada
apropriadamente pelas autoridades nacionais, informações pertinentes às partes que compoñam máquinas. / Came S.p.a. zobowiązuje się do udzielenia informacji dotyczących maszyn
nieukończonych na odpowiednio umotywowana prośbę, złożoną przez kompetentne organy państwowe. / Came S.p.a. verbindt zich ertoe om op met redenen omkleed verzoek van de
nationale autoriteiten de relevante informatie voor de niet voltooidde machine te verstrekken.

VIETA / FORBIDS / VERBIETET / INTERDIT / PROHIBE / PROIBE / ZABRANIA SIE / VERBIEDT

la messa in servizio finché la macchina finale in cui deve essere incorporata non è stata dichiarata conforme, se dal caso alla 2006/42/CE. / commissioning of the above mentioned until such
moment when the final machine into which they must be incorporated, has been declared compliant, it pertains, to 2006/42/CE / die Inbetriebnahme bevor die „Endmaschine“ in die die
unvollständige Maschine eingebaut wird, als konform erklärt wurde, gegebenenfalls gemäß der Richtlinie 2006/42/EU. / la mise en service tant que la machine finale dans laquelle elle doit
être incorporée n'a pas été déclarée conforme, le cas échéant, à la norme 2006/42/CE. / la puesta en servicio hasta que la máquina final en la que será incorporada no haya sido declarada
de conformidad de acuerdo a la 2006/42/CE / a colocação em funcionamento, até que a máquina final, onde devem ser incorporadas, não for declarada em conformidade, se de acordo
com a 2006/42/CE. / Uruchomienia urządzenia do czasu, kiedy maszyna, do której ma być wbudowany, nie zostanie oceniona jako zgodna z wymogami dyrektywy 2006/42/WE, jeśli taka
procedura była konieczna. / deze in werking te stellen zolang de eindmachine waarin de niet voltooidde machine moet worden ingebouwd in overeenstemming is verklaard, indien toepasselijk
met de richtlijn 2006/42/EG.

Dosson di Casier (TV)
9 Novembre / November / November /
November / Noviembre / Novembro /
Listopad / November 2018

Amministratore Delegato / Managing Director /
General Direktor / Directeur Général / Director General /
Administrador Delegado / Dyrektor Zarządzający /
Algemeen Directeur

Andrea Menuzzo

Fascicolo tecnico a supporto / Supporting technical dossier / Unterstützung technische Dossier / soutien dossier technique / apoya expediente
técnico / apoiar dossier técnico / wspieranie dokumentacji technicznej / ondersteunende technische dossier: 801MS-0320

Came S.p.a.

Via Martiri della Libertà, 15 - 31030 Dosson di Casier - Treviso - Italy - Tel. (+39) 0422 4940 - Fax (+39) 0422 4941
info@came.it - www.came.com

Cap. Soc. 1.610.000,00 € - C.F. e P.I. 03481280265 - VAT IT 03481280265 - REA TV 275359 - Reg Imp. TV 03481280265



CAME S.P.A.

Via Martiri della Libertà, 15
31030 Dosson di Casier
Treviso - Italy
Tél. (+39) 0422 49 40
Fax (+39) 0422 49 41

CAME.COM

Fabbricante / Manufacturer / Hersteller / Fabricant / Fabricante / Fabricante
/ Wytwórca / Fabrikant

Came S.p.a.

indirizzo / address / adresse / adresse / direccìon / endereço / adres / adres
Via Martiri della Libertà 15 - 31030 Dosson di Casier, Treviso - Italy



DICHIARA CHE LE AUTOMAZIONI PER CANCELLI SCORREVOLI / DECLARES THAT THE DRIVES FOR SLIDING GATES /
ERKLÄRT DASS DIE AUTOMATISIERUNGEN FÜR SCHIEBETÖRE / DECLARE QUE LES AUTOMATISATIONS POUR
PORTAILS COULISSANTS / DECLARA QUE LAS AUTOMATIZACIONES PARA PUERTAS CORREDERAS / DECLARA QUE AS
AUTOMATIZAÇÕES PARA PORTÕES DE CORRER / OSWADCZA ZE AUTOMATYKA DO BRAM PRZESUWNYCH /
VERKLAART DAT DE AUTOMATISERING VOOR SCHUIFHEKKEN

BKV15AGS ; BKV20AGS ; BKV25AGS
BKV15ALS ; BKV20ALS ; BKV25ALS
BKV15RGS ; BKV20RGS ; BKV15AGE
BKV20AGE ; BKV25AGE

SONO CONFORMI ALLE DISPOSIZIONI DELLE SEGUENTI DIRETTIVE / THEY COMPLY WITH THE PROVISIONS OF THE FOLLOW-
ING DIRECTIVES / DEN VORGABEN DER FOLGENDEN RICHTLINIEN ENTSPRECHEN / SONT CONFORMES AUX DISPOSITIONS
DES DIRECTIVES SUIVANTES / CUMPLEN CON LAS DISPOSICIONES DE LAS SIGUIENTES DIRECTIVAS / ESTÃO DE ACORDO
COM AS DISPOSIÇÕES DAS SEQUENTES DIRECTIVAS / SA ZGODNE Z POSTANOWIENIAMI NASTĘPUJĄCYCH DYREKTYW
EUROPEJSKICH / VOLDOEN AAN DE VOORSCHRIFTEN VAN DE VOLGENDE RICHTLIJNEN:

- COMPATIBILITÀ ELETTRROMAGNETICA / ELECTROMAGNETIC COMPATIBILITY / ELEKTROMAGNETISCHE
VERTRÄGLICHKEIT / COMPATIBILITÉ ÉLECTROMAGNETIQUE / COMPATIBILIDAD ELECTROMAGNETICA / COMPATIBIL-
DADE ELETROMAGNETICA / KOMPATYBILNOŚCI ELEKTROMAGNETYCZNEJ / ELEKTROMAGNETISCHE COMPATIBI-
LITEIT : 2014/30/UE.

Riferimento norme armonizzate ed altre norme tecniche / Refer to
European regulations and other technical regulations / Harmonisierte
Bezugsnormen und andere technische Vorgaben / Référence aux normes
harmonisées et aux autres normes techniques / Referencia normas
armonizadas y otras normas técnicas / Referência de normas harmoniza-
das e outras normas técnicas / Odnosne normy ujednoliconé i inne normy
techniczne / Geharmoniseerde en andere technische normen waarnaar is
verwezen

EN 61000-6-2:2005
EN 61000-6-3:2007+A1:2011
EN 62233:2008
EN 60335-1:2012+A11:2014
EN 60335-2-103:2015

RISPETTANO I REQUISITI ESSENZIALI APPLICATI / MEET THE APPLICABLE ESSENTIAL REQUIREMENTS / DEN WESENTLIJEN
ANGEWANDTEN ANFORDERUNGEN ENTSPRECHEN / RESPECTENT LES CONDITIONS REQUISES NECESSAIRES APPLIQUEES /
/ CUMPLEN CON LOS REQUISITOS ESSENCIALES APLICADOS / RESPETAM O REQUISITOS ESSENCIAIS APLICADOS /
SPEŁNIJA PODSTAWOWE WYMAGANIE WYRUNKI / VOLDOEN AAN DE TOEPASBARE MINIMUM EISEN:

1.1.3; 1.1.5; 1.2.1; 1.2.2; 1.3.2; 1.3.7; 1.3.8.1; 1.4.1; 1.4.2; 1.5.1; 1.5.6; 1.5.8; 1.5.9; 1.5.9; 1.5.13; 1.6.1; 1.6.3; 1.6.4;
1.7.1; 1.7.2; 1.7.4

PERSONA AUTORIZZATA A COSTITUIRE LA DOCUMENTAZIONE TECNICA PERTINENTE / PERSON AUTHORISED TO COMPILE THE RELEVANT TECHNICAL DOCUMENTATION /
PERSON DIE BEVOLLMÄCHTIGT IST, DIE RELEVANTEN TECHNISCHEN UNTERLAGEN ZUSAMMENZUSTELLEN / DOCUMENTATION TECHNIQUE SPECIFIQUE D'AUTORISATION
A CONSTRUIRE DE / PERSONA FACULTADA PARA ELABORAR LA DOCUMENTACIÓN TÉCNICA PERTINENTE / PESSOA AUTORIZADA A CONSTITUIR A DOCUMENTAÇÃO TÉCNICA
PERTINENTE / OSOBA UPOWAZNIONA DO ZREDAGOWANIA DOKUMENTACJI TECHNICZNEJ / DIEGENE DIE GEMACHTIGD IS DE RELEVANTE TECHNISCHE DOCUMENTEN
SAMEN TE STELLEN.

CAME S.p.a.

La documentazione tecnica pertinente è stata compilata in conformità all'allegato VIB. / The pertinent technical documentation has been drawn up in compliance with attached
document VIB. / Die relevante technische Dokumentation wurde entsprechend der Anlage VIB ausgestellt. / La documentation technique spécifique a été remplie conformément à
l'annexe VIB. / La documentación técnica pertinente ha sido rellenada en cumplimiento con el anexo VIB. / A documentação técnica pertinente foi preenchida de acordo com o anexo
VIB. / Odnosna dokumentacja techniczna została zredagowana zgodnie z załącznikiem VIB. / De technische documentatie terzake is opgesteld in overeenstemming met de bijlage VIB.

CAME S.p.a. si impegna a trasmettere, in risposta a una richiesta adeguatamente motivata delle autorità nazionali, informazioni pertinenti sulle quasi macchine, e / Came S.p.a., following
a duly motivated request from the national authorities, undertakes to provide information related to the quasi machines, and / Die Firma Came S.p.a. verpflichtet sich auf eine angemessen
motiviert Anfrage der staatlichen Behörden Informationen über die unvollständigen Maschinen, zu übermitteln, und / Came S.p.a. s'engage à transmettre, en réponse à une demande
bien fondée de la part des autorités nationales, les renseignements relatifs aux quasi machines. / Came S.p.a. se compromete a transmitir, como resposta a una solicitud adecuadamente
fundada por parte de las autoridades nacionales, informaciones relacionadas con las cuasimáquinas. / Came S.p.a. compromete-se em transmitir, em resposta a uma solicitação motivada
apropriadamente pelas autoridades nacionais, informações pertinentes às partes que compoñam máquinas. / Came S.p.a. zobowiązuje się do udzielenia informacji dotyczących maszyn
nieukonczonych na odpowiednio umotywowana prośbę, złożoną przez kompetentne organy państwowe. / Came S.p.a. verbindt zich ertoe om op met redenen omkleed verzoek van de
nationale autoriteiten de relevante informatie voor de niet voltooidde machine te verstrekken.

VIETA / FORBIDS / VERBIETET / INTERDIT / PROHIBE / PROIBE / ZABRANIA SIE / VERBIEDT

la messa in servizio finché la macchina finale in cui deve essere incorporata non è stata dichiarata conforme, se dal caso alla 2006/42/CE. / commissioning of the above mentioned until such
moment when the final machine into which they must be incorporated, has been declared compliant, it pertains, to 2006/42/CE / die Inbetriebnahme bevor die „Endmaschine“ in die die
unvollständige Maschine eingebaut wird, als konform erklärt wurde, gegebenenfalls gemäß der Richtlinie 2006/42/EU. / la mise en service tant que la machine finale dans laquelle elle doit
être incorporée n'a pas été déclarée conforme, le cas échéant, à la norme 2006/42/CE. / la puesta en servicio hasta que la máquina final en la que será incorporada no haya sido declarada
de conformidad de acuerdo a la 2006/42/CE. / Uruchomienia urządzenia do czasu, kiedy maszyna, do której ma być wbudowany, nie zostanie oceniona jako zgodna z wymogami dyrektywy 2006/42/WE, jeśli taka
procedura była konieczna. / deze in werking te stellen zolang de eindmachine waarin de niet voltooidde machine moet worden ingebouwd in overeenstemming is verklaard, indien toepasselijk,
met de richtlijn 2006/42/EG.

Dosson di Casier (TV)
9 Novembre / November / November /
November / Noviembre / Novembro /
Listopad / November 2018

Amministratore Delegato / Managing Director /
General Direktor / Directeur Général / Director General /
Administrador Delegado / Dyrektor Zarządzający /
Algemeen Directeur

Andrea Menuzzo

Fascicolo tecnico a supporto / Supporting technical dossier / Unterstützung technische Dossier / soutien dossier technique / apoyo expediente
técnico / apoiar dossier técnico / wspieranie dokumentacji technicznej / ondersteunende technische dossier: 801MS-0320

Came S.p.a.

Via Martiri della Libertà, 15 - 31030 Dosson di Casier - Treviso - Italy - Tel. (+39) 0422 4940 - Fax (+39) 0422 4941
info@came.it - www.came.com

Cap. Soc. 1.610.000,00 € - C.F. e P.I. 03481280265 - VAT IT 03481280265 - REA TV 275359 - Reg Imp. TV 03481280265



CAME S.P.A.

Via Martiri della Libertà, 15
31030 Dosson-di-Kazьep
Treviso - Italy (Italia)
Тел.: (+39) 0422 4940
Факс: (+39) 0422 4941

CAME.COM